



Drilling Engineering

This manual and its content is copyright of Heriot Watt University © 2005

Any redistribution or reproduction of part or all of the contents in any form is prohibited.

All rights reserved. You may not, except with our express written permission, distribute or commercially exploit the content. Nor may you reproduce, store in a retrieval system or transmit in any form or by any means, electronic, mechanical, photocopying, recording or otherwise without the prior permission of the Copyright owner.

Acknowledgements:

The author and Department of Petroleum Engineering would like to thank the following companies for their advice and guidance, and various other contributions to the material used in this manual:

Baker-Hughes Inteq
Dowell Schlumberger
Halliburton
Sperry-Sun
ABB Vetco Gray Ltd
Hughes - Christensen
Hydril
Gyrodatta
Smith International
American Petroleum Institute
Varco

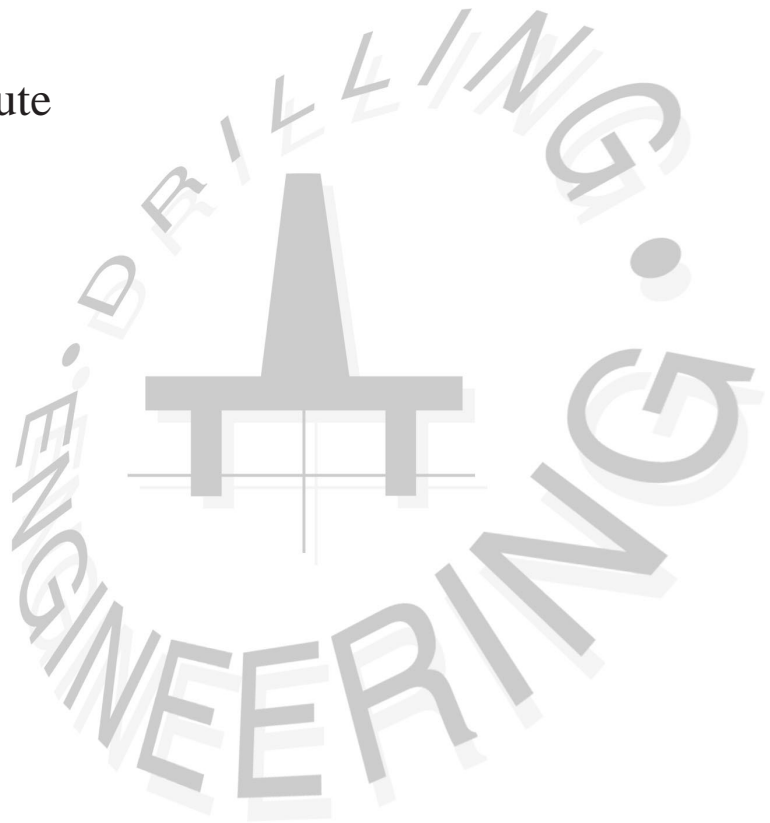

All rights reserved no part of this publication may be reproduced, stored in a retrieval system or transmitted in any form or by any means, electronic, mechanical, photocopying, recording or otherwise without the prior permission of the Copyright owner.

GLOSSARY

- 1* *OVERVIEW*
- 2* *RIG COMPONENTS*
- 3* *DRILLSTRING*
- 4* *DRILLBITS*
- 5* *FORMATION PRESSURES*
- 6* *WELL CONTROL*
- 7* *CASING*
- 8* *CEMENT*
- 9* *DRILLING FLUIDS*
- 10* *HYDRAULICS*
- 11* *DIRECTIONAL DRILLING*
- 12* *DIRECTIONAL SURVEYING*
- 13* *MEASUREMENT WHILE DRILLING*
- 14* *SUBSEA*
- 15* *EXAMINATION AND MODEL SOLUTIONS*



Units

PARAMETER	SYMBOL	TO CONVERT FROM OILFIELD UNITS	TO	MULTIPLY BY
Area	A	ft ²	m ²	9.29 x 10 ⁻²
			cm ²	9.29 x 10 ²
			in ²	1.44 x 10 ²
Density	ρ	lb/gal (ppg)	kg/m ³	1.198 x 10 ²
			g/cm ³	1.198 x 10 ⁻¹
			lb/ft ³	7.48
			lb/bbl	42
Force	F	lb	N	4.45
			dyne	4.45 x 10 ⁵
Length	L, l	ft	m	30.48 x 10 ⁻²
Depth	D, d		mile	1.89 x 10 ⁻⁴
Height	h	micron	m	1.0 x 10 ⁻⁶
			in.	3.94 x 10 ⁻⁵
Mass	m	lb	kg	4.54 x 10 ⁻¹
			tonne	4.54 x 10 ⁻⁴
			short ton	5.0 x 10 ⁻⁴
Power	HP	horsepower (HP)	KW	7.46 x 10 ⁻¹
Pressure	P	lb/in ²	Pascal	6.89 x 10 ³
			bar	6.89 x 10 ⁻²
			dyne/cm ²	6.89 x 10 ⁴
			atmosphere	6.89 x 10 ⁻²
Velocity	v	ft/sec	m/sec	30.48 x 10 ⁻²
Viscosity	μ	cp	pascal-sec	1.0 x 10 ⁻³
Volume	V	bbl	m ³	1.59 x 10 ⁻¹
			cm ³	1.59 x 10 ⁵
			ft ³	5.615
			gallon	42
			in ³	9.70 x 10 ³
Flowrate	Q	gpm	m ³ /sec	6.31 x 10 ⁻⁵
			ft ³ /min	1.337 x 10 ⁻¹
			bbl/min.	2.381 x 10 ⁻²
			bbl/day	3.429 x 10 ¹

Glossary of Terms

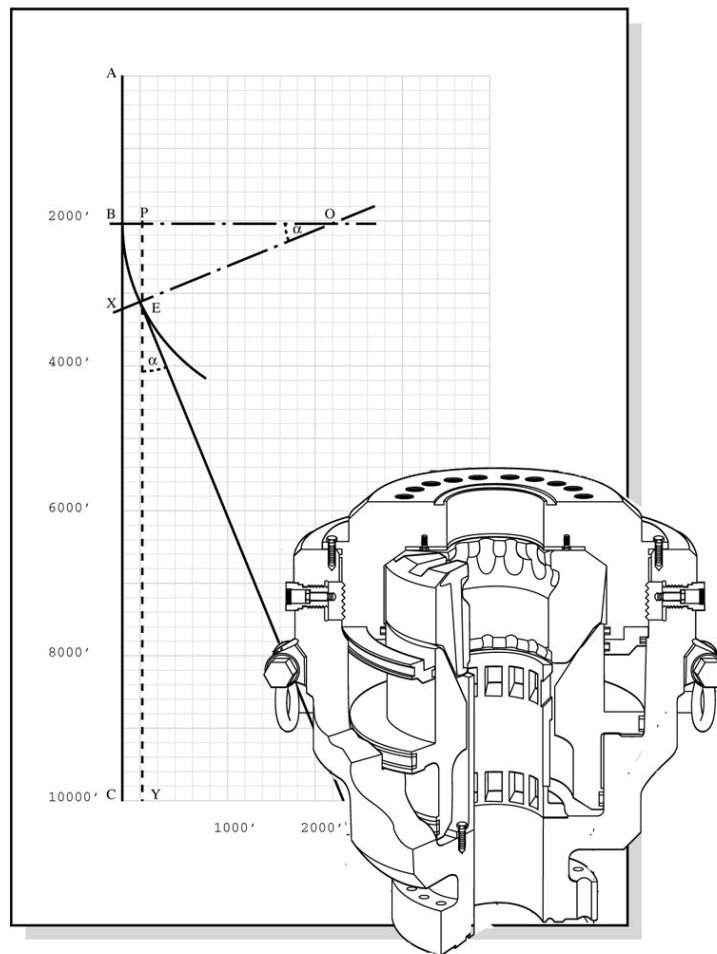

Glossary of Terms





DEFINITIONS AND GLOSSARY OF TERMS

A **Abandon a well** v : to stop producing hydrocarbons when the well becomes unprofitable. A wildcat may be abandoned after poor results from a well test. Mechanical and cement plugs are placed in the wellbore to prevent fluid migration to surface and between different zones.

Abnormal pressure n : a formation pressure which is greater or less than the "normal" formation fluid hydrostatic pressure. Such pressures may be classified as "subnormal" (lower than normal) or "overpressured" (higher than normal).

Accelerometer n : a surveying instrument which measures components of the Earth's gravitational field.

Acidise v : to apply acids to the walls of oil and gas wells to remove any material which may obstruct flow into the wellbore.

Adjustable choke n : a choke in which the rate of flow is controlled by adjusting a conical needle and seat.

Air drilling n : a method of drilling that uses compressed air as the circulating medium.

Angle unit n : the component of a survey instrument used to measure inclination.

Annular preventer n : a large BOP valve that forms a seal in the annular space between the wellbore and the drillpipe. It is usually installed above the ram type preventers in the BOP stack.

Annulus n : the space between the drillstring and open hole or drillstring and cased hole in the wellbore.

Anticline n : a configuration of folded and stratified rock layers in the shape of an arch. Often associated with a trap.

A.P.I. abbr : American Petroleum Institute. The leading standardising organisation on oilfield drilling and production equipment.

A.P.I. gravity n : a measure of the density of liquid petroleum products, expressed in degrees. It can be derived from the following equation:

$$\text{API Gravity (degrees)} = \frac{141.5}{\text{Specific Gravity}} - 131.5$$



Azimuth n : used in directional drilling as the direction of the trajectory of the wellbore measured in degrees (0-359) clockwise from True North or Magnetic North.

Back off v : to disconnect a section of stuck drillpipe by unscrewing one of the connections above the stuckpoint.

Back up :

1. v - to hold one section of pipe while another is being screwed into or out of it (as in back up tongs).
2. n - a piece of equipment held in reserve in case another piece fails.

Badger bit n : a specially designed bit with one large nozzle, which can be used as a deflecting tool in soft formations.

Bail n : a rounded steel bar which supports the swivel and connects it to the hook. May also apply to the steel bars which connect the elevators to the hook (links).

Ball up v : buildup of a mass of sticky material (drill cuttings) on components of drillstring (especially bits and stabilisers)

Barge n : a flat decked, shallow draft vessel which may accommodate a drilling rig, or be used to store equipment and materials or for living quarters.

Barite (Baryte) n : Barium Sulphate (BaSO_4), a mineral used as a weighting material to increase mud weight (specific gravity = 4.2).

Barrel n : a measure of volume for fluids. One barrel (bbl) = 42 U.S. gallons = 0.15899 cubic metres. The term bbl is derived from the **blue barrels** in which oil was originally transported.

Bed n : a geological term to specify one particular layer of rock.

Bell nipple n : In marine drilling, the uppermost component of the marine riser attached to the telescopic joint. The top of the nipple is expanded to guide drilling tools into the well.

Bentonite n : a finely powdered clay material (mainly montmorillonite) which swells when mixed with water. Commonly used as a mud additive, and sometimes referred to as "gel".

Bent sub n : a short piece of pipe whose axis is deviated 1° - 3° off vertical. Used in directional drilling as a deflecting tool.

Bit n : the cutting element at the bottom of the drillstring, used for boring through the rock.

B

Glossary of Terms

Bit breaker n : a heavy metal plate which fits into the rotary table and holds the bit while it is being connected to or disconnected from the drillstring.

Bit record n : a report containing information relating to the operating parameters and performance of the bits run in a well.

Bit sub n : a short length of pipe installed immediately above the bit. The threads on the bit sub accept the pin thread on the bit and the pin thread for the drillcollars.

Bit walk n : the tendency for the bit and drillstring to wander off course by following the direction of rotation (usually to the right) in a directionally drilled well.

Blind rams n : one of the valves on the BOP stack. It is designed to close off the wellbore when the drillstring is out of the hole.

Blocks n : an assembly of pulleys on a common framework.

Bloody line n : the discharge pipe from a well being drilled with compressed air.

Blow out n : an uncontrolled flow of formation fluids into the atmosphere at surface.

BOP abbr : **Blow Out Preventer**. A valve installed on top of the wellhead to control wellbore pressure in the event of a kick.

BOP stack n : an assembly of BOPs consisting of annular preventers and ram type preventers. For land drilling the BOP stack is installed just below the rig floor, while for floating rigs the stack is positioned on the seabed.

Borehole n : the hole made by the drill bit.

Bottom hole assembly (BHA) n : the part of the drillstring which is just above the bit and below the drillpipe. It usually consists of drill collars, stabilisers and various other components.

Bottom hole pressure (bhp) n : the pressure,
1. at the bottom of the borehole, or
2. at a point opposite the producing formation.

Box n : the female section of a tool joint or other connection.

Brake n: the device operated by the driller to stop the downward motion of the travelling block and therefore the drillstring.

Breakout v : to unscrew one section of pipe from another.

Bridge n : an obstruction in the borehole usually caused by the borehole wall caving in.

BRT abbr : **Below Rotary Table**. Reference point for measuring depth.



Building assembly n : a BHA specially designed to increase the inclination (drift angle) of the wellbore.

Build up rate n : the rate at which drift angle is increasing as the wellbore is being deviated from vertical. Usually measured in degrees per 100 ft drilled.

Build up section n : that part of the wellbore's trajectory where the drift angle is increasing.

Bumper sub n : a drilling tool, placed in the BHA, consisting of a short stroke slip joint which allows a more constant WOB to be applied when drilling from a floating rig.

Cable tool drilling n : an earlier method of drilling used before the introduction of modern rotary methods. The bit was not rotated but reciprocated by means of a strong wire rope.

Caliper log n : a tool run on electric wireline which measures the diameter of the wellbore. It may be used for detecting washouts, calculating cement volumes, or detecting internal corrosion of casing.

Cap rock n : an impermeable layer of rock overlying an oil or gas reservoir and preventing the migration of fluids.

Cased hole n : that part of the hole which is supported by a casing which has been run and cemented in place.

Casing n : large diameter steel pipe which is used to line the hole during drilling operations.

Casing head Housing n : a large receptacle which is installed on top of the surface casing string. It has an upper flanged connection. Once it is installed it provides: a landing shoulder for the next casing string; and a flanged connection for the BOP stack to be connected to the well.

Casing head Spool n : a large receptacle which is installed on top of the casing head housing or a previous spool. It has both an upper and lower flanged connection. Once it is installed it provides: a landing shoulder for the next casing string; access to the annulus between the casing strings and a flanged connection for the BOP stack to be connected to the well.

Casing hanger n : a special component which is made up on top of the casing string to suspend the casing from the previous casing housing or spool.

Casing shoe n : a short section of steel pipe filled with concrete and rounded at the bottom. This is installed on the bottom of the casing string to guide the casing past any ledges or irregularities in the borehole. Sometimes called a guide shoe.

Casing string n : the entire length of all the casing joints run into the borehole.

Cathead n : a spool shaped attachment on a winch, around which rope is wound. This can be used for hoisting operations on the rig floor.

Caving: 1. v: collapse of the walls of the borehole. Also referred to as "sloughing".
2. n: a small part of the borehole wall that has collapsed into the hole.

Centraliser n : a device secured around the casing which is designed to support and centralise the casing in deviated wellbores.

Centrifugal pump n : a pump consisting of an impellor, shaft and casing which discharges fluid by centrifugal force. Often used for mixing mud.

Centrifuge n : a piece of solids control equipment which separates out particles of varying density.

Cement Slurry n: A mixture of cement powder, water and additives which harden to form a cement sheath or cement plug in a well.

Cementing v : the placement of a liquid slurry of cement and water inside or outside of the casing. Primary cementing is carried out immediately after the casing is run. Secondary cementing is carried out when remedial work is required.

Cement channeling v : the irregular displacement of mud by cement, leaving voids in the cement sheath between the casing and the borehole, thereby reducing the effectiveness of the cement sheath.

Cement head n : a manifold system installed on the top of the casing which allows the cement slurry to be pumped from the cement unit down the casing string. The cement head is also used for releasing the top and bottom cement plugs.

Cement plug n :

1. A specific volume of cement placed at some point in the wellbore to seal off the well.
2. A device used during a primary cement job to separate the cement slurry from contaminating fluids in the casing. A wiper plug is pumped ahead of the slurry and a shut off plug behind the slurry.

Chain tongs n : a tool used by roughnecks on the rig floor to tighten or loosen a connection. The tool consists of a long handle and an adjustable chain which will fit a variety of pipe sizes.

Check valve n : a valve which permits flow in one direction only.

Choke n : an orifice installed in a line to restrict and control the flow rate.

Choke line n : a pipe connected to the BOP stack which allows fluids to be circulated



out of the annulus and through the choke manifold when a well killing operation is being performed.

Choke manifold n : an arrangement of pipes, valves and chokes which allows fluids to be circulated through a number of routes.

Christmas tree n : an assembly of control valves and fittings installed on top of the wellhead. The Christmas tree is installed after the well has been completed and is used to control the flow of oil and gas.

Circulate v : to pump drilling fluid through the drillstring and wellbore, returning to the mud pits. This operation is carried out during drilling and is also used to improve the condition of the mud while drilling is suspended.

Clay n : a term used to describe the aluminium silicate minerals which are plastic when wet and have no well-developed parting along bedding planes. Such material is commonly encountered while drilling a well.

Clay minerals n : the constituents of a clay which provide its plastic properties. These include kaolinite, illite, montmorillonite and vermiculite.

Closure n : the shortest horizontal distance from a particular survey station back to the reference point.

Combination string n : a casing string which is made up of various different grades or weights of casing (sometimes referred to as a tapered string when different sizes of casing are used).

Company man n : an employee of an operating company whose job is to represent the operator's interests on the drilling rig (sometimes referred to as "drilling supervisor" or "company man").

Compass unit n : the component of a survey instrument used to measure azimuth.

Completion

1. v : the activities and methods used to prepare a well for the production of oil or gas.
2. n: the tubing and accessories installed in the production casing and through which the produced fluid flows to surface.

Conductor line n : a small diameter wireline which carries electric current. This is used for logging tools and steering tools.

Conductor pipe n : a short string of casing of large diameter which is normally the first casing string to be run in the hole.

Connection v : the joining of a section of drillpipe to the top of the drillstring as drilling proceeds.

Core n : a cylindrical rock sample taken from the formation for geological analysis.

Core barrel n : a special tool which is installed at the bottom of the drillstring to capture and retain a core sample which is then recovered when the string is pulled out of the hole.

Core Bit (Core Head) n: A donut shaped drilling bit used just below the core barrel to cut a cylindrical sample of rock.

Correction run n : a section of hole which must be directionally drilled to bring the well path back onto the planned course.

Crater n : a large hole which develops at the surface of a wellbore caused by the force of escaping gas, oil or water during a blowout.

Cross-over n : a sub which is used to connect drill string components which have different types or sizes of threads.

Crown block n : an assembly of sheaves or pulleys mounted on beams at the top of the derrick over which the drilling line is reeved.

Cuttings n : the fragments of rock dislodged by the bit and carried back to surface by the drilling fluid.

D **Deadline** n : that part of the drilling line between the crown block and the deadline anchor. This line remains stationary as the travelling block is hoisted.

Deadline anchor n : a device to which the deadline is attached and securely fastened to the derrick substructure.

Defecting tool n : a piece of drilling equipment which will change the inclination and/or direction of the hole.

Degasser n : a piece of equipment used to remove unwanted gas from the drilling mud.

Density n : the mass of a substance per unit volume. Drilling fluid density is usually expressed in psi/ft, Kg/m³, g/cc or ppg.

Departure n : one of the coordinates used to plot the path of the well on the horizontal plane (along the x axis).

Derrick n : a large load-bearing structure from which the hoisting system and therefore the drillstring is suspended.

Derrickman n : a member of the drilling crew whose work station is on the monkey board high up in the derrick. From there he handles the upper end of the stands of



drillpipe being raised or lowered. He is also responsible for maintaining circulation equipment and carrying out routine checks on the mud.

Desander n : a hydrocyclone used to remove sand from the drilling mud.

Desilter n : a hydrocyclone used to remove fine material (silt size) from the drilling mud.

Development well n : a well drilled in a proven field to exploit known reserves. Usually one of several wells drilled from a central platform.

Deviation n : a general term referring to the horizontal displacement of the well. May also be used to describe the change in drift angle from vertical (inclination).

Diamond bit n : a bit which has a steel body surfaced with diamonds to increase wear resistance.

Directional drilling : n the intentional deviation of a wellbore in order to reach a certain objective some distance from the rig.

Directional surveying n : a method of measuring the inclination and direction of the wellbore by using a downhole instrument. The well must be surveyed at regular intervals to accurately plot its course.

Discovery well n : the first well drilled in a new field which successfully indicates the presence of oil or gas reserves.

Displace v : to move a liquid (e.g. cement slurry) from one position to another by means of pumping another fluid behind it.

Displacement fluid n : the fluid used to force cement slurry or some other material into its intended position. (e.g. drilling mud may be used to displace cement out of the casing into the annulus).

Dog house n : a small enclosure on the rig floor used as an office by the driller and as a storage place for small items.

Dog leg n : a sharp bend in the wellbore which may cause problems tripping in and out of the hole.

Dog leg severity n : a parameter used to represent the change in inclination and azimuth in the well path (usually given in degrees per 100 ft).

Dope n : a lubricant for the threads of oilfield tubular goods.

Double n : a section of drillpipe, casing or tubing consisting of two single lengths screwed together.

Downhole motor n : a special tool mounted in the BHA to drive the bit without

rotating the drill string from surface (see positive displacement motor).

Downhole telemetry n : the process whereby signals are transmitted from a downhole sensor to a surface readout instrument. This can be done by a conductor line (as on steering tools) or by mud pulses (as in MWD tools).

Drag n : The force required to move the drillstring due to the drillstring being in contact with the wall of the borehole.

Drag bit n : a drilling bit which has no cones or bearings but consists of a single unit with a cutting structure and circulation passageways. The fishtail bit was an early example of a drag bit, but is no longer in common use. Diamond bits are also drag bits.

Drawworks n : the large winch on the rig which is used to raise or lower the drill string into the well.

Drift angle n : the angle which the wellbore makes with the vertical plane (see inclination).

Drill collar n : a heavy, thick-walled steel tube which provides weight on the bit to achieve penetration. A number of drill collars may be used between the bit and the drillpipe.

Driller n : the employee of the drilling contractor who is in charge of the drilling rig and crew. His main duties are to operate the drilling equipment and direct rig floor activities.

Drilling contractor n : an individual or company that owns the drilling rig and employs the crew required to operate it.

Drilling crew n : the men required to operate the drilling rig on one shift or tour. This normally comprises a driller, derrickman and 2 or 3 roughnecks.

Drilling fluid n : the fluid which is circulated through the drillstring and up the annulus back to surface under normal drilling operations. Usually referred to as mud.

Drilling line n : the wire rope used to support the travelling block, swivel, kelly and drillstring.

Drill pipe n : a heavy seamless pipe which is used to rotate the bit and circulate the drilling fluid. Lengths of drill pipe 30ft long are coupled together with tool joints to make the drillstring.

Drill ship n : a specially designed ship which is used to drill a well at an offshore location.

Drill stem n : used in place of drillstring in some locations. Describes all the drilling components from the swivel down to the bit.



Drill stem test (DST) n : a test which is carried out on a well to determine whether or not oil or gas is present in commercial quantities. The downhole assembly consists of a packer, valves and a pressure recording device, which are run on the bottom of the drill stem.

Drillstring n : the string of drill pipe with tool joints which transmits rotation and circulation to the drill bit. Sometimes used to include both drill collars and drill pipe.

Drop off section n : that part of the well's trajectory where the drift angle is decreasing (i.e. returning to vertical).

Duplex pump n : a reciprocating positive displacement pump having 2 pistons which are double acting. Used as the circulating pump on some older drilling rigs.

Dynamic positioning n : a method by which a floating drilling rig or drill ship is kept on location. A control system of sensors and thrusters is required.

Easting n : one of the co-ordinates used to plot a deviated well's position on the horizontal plane (along the x axis).

E

Electric logging v : the measurement of certain electrical characteristics of formations traversed by the borehole. Electric logs are run on conductor line to identify the type of formations, fluid content and other properties.

Elevators n : a lifting collar connected to the travelling block, which is used to raise or lower pipe into the wellbore. The elevators are connected to the travelling block by links or bails.

Emulsion n : a mixture in which one liquid (dispersed phase) is uniformly distributed in another liquid (continuous phase). Emulsifying agents may be added to stabilise the mixture.

Exploration well n : a well drilled in an unproven area where no oil and gas production exists (sometimes called a "wildcat").

Fastline n : the end of the drilling line which is attached to the drum of the drawworks.

Fault n : a geological term which denotes a break in the subsurface strata. On one side of the fault line the strata has been displaced upwards, downwards or laterally relative to its original position.

Field n : a geographical area in which oil or gas wells are producing from a continuous reservoir.

F

Filter cake n : the layer of concentrated solids from the drilling mud that forms during natural filtration on the sides of the borehole. Sometimes called "wall cake" or "mud cake".

Filter press n : a device used in the measurement of the mud's filtration properties.

Filtrate n : a fluid which has passed through a filter. In drilling it usually refers to the liquid part of the mud which enters the formation.

Filtration v : the process by which the liquid part of the drilling fluid is able to enter a permeable formation, leaving a deposit of mud solids on the borehole wall to form a filter cake.

Fish n : any object accidentally left in the wellbore during drilling or workover operations, which must be removed before work can proceed.

Fishing v : the process by which a fish is removed from the wellbore. It may also be used for describing the recovery of certain pieces of downhole completion equipment when the well is being reconditioned during a workover.

Fishing tool n : a specially designed tool which is attached to the drill string in order to recover equipment lost in the hole.

Flange up v : to connect various components together (e.g. in wellheads or piping systems).

Flare n : an open discharge of fluid or gas to the atmosphere. The flare is often ignited to dispose of unwanted gas around a completed well.

Flex joint n : a component of the marine riser system which can accommodate some lateral movement when drilling from a floater.

Float collar n : a special device inserted one or two joints above the bottom of a casing string. The float collar contains a check valve which permits fluid flow in a downward direction only. The collar thus prevents the back flow of cement once it has been displaced.

Floater n : general term used for a floating drilling rig.

Float shoe n : a short cylindrical steel component which is attached to the bottom of a casing string. The float shoe has a check valve and functions in the same manner as the float collar. In addition the float shoe has a rounded bottom which acts as a guide shoe for the casing.

Float sub n : a check valve which prevents upward flow through the drill string.

Flocculation v : the coagulation of solids in a drilling fluid produced by special additives or contaminants in the mud.



Fluid loss v : the transfer of the liquid part of the mud to the pores of the formation. Loss of fluid (water plus soluble chemicals) from the mud to the formation can only occur where the permeability is sufficiently high. If the pores are large enough the first effect is a "spurt loss", followed by the build up of solids (filter cake) as filtration continues.

Formation n : a bed or deposit composed throughout of substantially the same kind of rock to form a lithologic unit.

Formation fluid n : the gas, oil or water which exists in the pores of the formation.

Formation pressure n : the pressure exerted by the formation fluids at a particular point in the formation. Sometimes called "reservoir pressure" or "pore pressure".

Formation testing v : the measurement and gathering of data on a formation to determine its potential productivity.

Fracture n : a break in the rock structure along a particular direction. Fractures may occur naturally or be induced by applying downhole pressure in order to increase permeability.

Fracture gradient n : a measure of how the strength of the rock (i.e. its resistance to break down) varies with depth.

Fulcrum assembly n : a bottom hole assembly which is designed to build hole inclination.

Gas cap n : the free gas phase which is sometimes found overlying an oil zone and occurs within the same formation as the oil.

Gas cut mud n : mud which has been contaminated by formation gas.

Gas show n : the gas that is contained in mud returns, indicating the presence of a gas zone.

Gas injector n : a well through which produced gas is forced back into the reservoir to maintain formation pressure and increase the recovery factor.

Gel n : a semi-solid, jelly-like state assumed by some colloidal dispersions at rest. When agitated the gel converts to a fluid state.

Gel strength n : the shear strength of the mud when at rest. Its ability to hold solids in suspension. Bentonite and other colloidal clays are added to the mud to increase gel strength.

Geostatic pressure n : the pressure exerted by a column of rock. Under normal conditions this pressure is approximately 1 psi per foot. This is also known as

"lithostatic pressure" or "overburden pressure".

Guideline tensioner n : a pneumatic or hydraulic device used to provide a constant tension on the wire ropes which run from the subsea guide base back to a floating drilling rig.

Guide shoe n : See Float Shoe.

Gumbo n : clay formations which contaminate the mud as the hole is being drilled. The clay hydrates rapidly to form a thick plug which cannot pass through a marine riser or mud return line.

Gunk n : a term used to describe a mixture of diesel oil, bentonite and sometimes cement which is used to combat lost circulation.

Gusher n : an uncontrolled release of oil from the wellbore at surface.

Gyro multi-shot n : a surveying device which measures and provides a series of photographic images showing the inclination and direction of the wellbore. It measures direction by means of a gyroscopic compass.

Gyro single-shot n : a surveying device which measures the inclination and direction of the borehole at one survey station. It measures direction by means of a gyroscopic compass

Gyroscope n : a wheel or disc mounted on an axle and free to spin rapidly about one axis, but free to rotate about one or both of the other two axes. The inertia of the wheel keeps the axis aligned with the reference direction (True North in directional survey tools).

H

Hole opener n : a special drilling tool which can enlarge an existing hole to a larger diameter.

Hook n : the large component attached to the travelling block from which the drill stem is suspended via the swivel.

Hopper n : a large funnel shaped device into which dry material (e.g. cement or powdered clay) can be poured. The purpose of the hopper is to mix the dry material with liquids injected at the bottom of the hopper.

H.W.D.P. abbr : heavy weight drill pipe. Thick walled drill pipe with thick walled sections used in directional drilling and placed between the drill collars and drill pipe.

Hydrostatic pressure n : the load exerted by a column of fluid at rest. Hydrostatic pressure increases uniformly with the density and depth of the fluid.



Inclination n : a measure of the angular deviation of the wellbore from vertical. Sometimes referred to as "drift angle".

Injection n : usually refers to the process whereby gas, water or some other fluid is forced into the formation under pressure.

Impermeable adj : preventing the passage of fluid through the pores of the rock.

Insert bit n : a type of roller cone bit where the cutting structure consists of specially designed tungsten carbide cutters set into the cones.

Intermediate casing n : a string of casing set in the borehole to keep the hole from caving and to seal off troublesome formations.

Invert oil emulsion mud n : a drilling fluid which contains up to 50% by volume of water, which is distributed as droplets in the continuous oil phase. Emulsifying agents and other additives are also present.

Iron roughneck n : an automated piece of rig floor equipment which can be used to make connections.

Jack-up rig n : an offshore drilling structure which is supported on steel legs.

Jet deflection n : a technique used in directional drilling to deviate the wellbore by washing away the formation in one particular direction. A special bit (badger bit) is used which has one enlarged nozzle which must be orientated towards the intended direction.

Jet sub n : a tool used at the bottom of the drill pipe when the conductor pipe is being jetted into position (this method of running the conductor is only suitable where the surface formations can be washed away by the jetting action).

Joint n : a single length of pipe which has threaded connections at either end.

Junk n : debris lost in the hole which must be removed to allow normal operations to continue.

Junk sub n : a tool run with the BHA, which is designed to recover pieces of debris left in the hole.

Kelly n : the heavy square or hexagonal steel pipe which runs through the rotary table and is used to rotate the drillstring.

Kelly bushing n : a device which fits into the rotary table and through which the kelly

passes. The rotation of the table is transmitted via the kelly bushing to the kelly itself. Sometimes called the “drive bushing”.

Kelly cock n : a valve installed between the kelly and the swivel. It is used to control a backflow of fluid up the drillstring and isolate the swivel and hose from high pressure.

Kelly spinner n : a pneumatically operated device mounted on top of the kelly which, when actuated, causes the kelly to rotate. It may be used to make connections by spinning up the kelly.

Key seat n : a channel or groove cut into the side of the borehole due to the dragging action of the pipe against a sharp bend (or dog leg).

Key seat wiper n : a tool made up in the drillstring to ream out any key seats which may have formed and thus prevent the pipe from becoming stuck.

Kick n : an entry of formation fluids (oil, gas or water) into the wellbore caused by the formation pressure exceeding the pressure exerted by the mud column.

Kill line n : a high pressure line connecting the mud pumps to the BOP stack through which mud can be pumped to control a kick.

Killing a well v : the process by which a well which is threatening to blow out is brought under control. It may also mean circulating water or mud into a completed well prior to workover operations.

KOP abbr : kick-off point. The depth at which the wellbore is deliberately deviated from the vertical.

L **Latitude** n : one of the co-ordinates used in plotting the wellpath on the horizontal plane (along the y axis).

Lead angle n : the direction at which the directional driller aims the well to compensate for bit walk. Lead angle is measured in degrees left or right of the proposed direction.

Liner n :

1. A string of casing which is suspended by a liner hanger from the inside of the previous casing string and does not therefore extend back to surface as other casing strings do.
2. A replaceable sleeve which fits inside the cylinder of a mud pump.

Liner hanger n : a slip type device which suspends the liner inside the previous casing shoe.

Location n : the place at which a well is to be drilled.

Log n : a systematic recording of data (e.g. driller’s log, electric log, etc.)



Lost circulation n : the loss of quantities of whole mud to a formation due to caverns, fractures or highly permeable beds. Also referred to as “lost returns”.

Magnetic declination n : the angle between True North and Magnetic North. This varies with geographical location, and also changes slightly each year.

M

Magnetic multi-shot n : a surveying instrument which provides a series of photographic discs showing the inclination and direction of the wellbore. It measures direction by means of a magnetic compass and so direction is referenced to Magnetic North.

Magnetic North n : the northerly direction in the earth’s magnetic field indicated by the needle of a magnetic compass.

Magnetometer n : a surveying device which measures the intensity and direction of the earth’s magnetic field.

Make up v : to assemble and join components together to complete a unit (e.g. to make up a string of casing).

Make hole v : to drill ahead

Marine riser n : the pipe which connects the subsea BOP stack with the floating drilling rig. The riser allows mud to be circulated back to surface, and provides guidance for tools being lowered into the wellbore.

Mast n : a portable derrick capable of being erected as a unit unlike a standard derrick which has to be built up.

Master bushing n : a sleeve which fits into and protects the rotary table and accommodates the slips and drives the kelly bushing.

Measured depth (MD) n : the distance measured along the path of the wellbore (i.e. the length of the drillstring).

Mill n : a downhole tool with rough, sharp cutting surfaces for removing metal by grinding or cutting.

Milled tooth bit n : a roller cone bit whose cutting surface consists of a number of steel teeth projecting from the surface of the cones.

Monel n : term used for a non-magnetic drill collar made from specially treated steel alloys so that it does not affect magnetic surveying instruments.

Monkey board n : the platform on which the derrickman works when handling stands of pipe.

Moon pool n : the central slot under the drilling floor on a floating rig.

Motion compensator n : a hydraulic or pneumatic device usually installed between the travelling block and hook. Its function is to keep a more constant weight on the drill bit when drilling from a floating vessel. As the rig heaves up and down a piston moves within the device to cancel out this vertical motion.

Mousehole n : a small diameter pipe under the derrick floor in which a joint of drill pipe is temporarily stored for later connection to the drillstring.

M.S.L. abbr : Mean Sea Level.

Mud n : common term for drilling fluid.

Mud balance n : a device used for measuring the density of mud or cement slurry. It consists of a cup and a graduated arm which carries a sliding (counterbalanced) weight and balances on a fulcrum.

Mud conditioning v : the treatment and control of drilling fluid to ensure that it has the correct properties. This may include the use of additives, removing sand or other solids, adding water and other measures. Conditioning may also involve circulating the mud prior to drilling ahead.

Mud engineer n : usually an employee of a mud service company whose main responsibility on the rig is to test and maintain the mud properties specified by the operator.

Mudline n : the seabed.

Mudlogging n : the recording of information derived from the examination and analysis of drill cuttings. This also includes the detection of oil and gas. This work is usually done by a service company which supplies a portable laboratory on the rig.

Mud motor n : a downhole component of the BHA which rotates the bit without having to turn the rotary table. The term is sometimes applied to both positive displacement motors and turbodrills.

Mud pits n : a series of open tanks in which the mud is mixed and conditioned. Modern rigs are provided with three or more pits, usually made of steel plate with built-in piping, valves and agitators.

Mud pump n : a large reciprocating pump used to circulate the drilling fluid down the well. Both duplex and triplex pumps are used with replaceable liners. Mud pumps are also called “slush pumps”.

Mud return line n : a trough or pipe through which the mud being circulated up the annulus is transferred from the top of the wellbore to the shale shakers. Sometimes called a “flowline”.



Mud screen n : shale shaker.

Mule shoe n : the guide shoe on the lower end of a survey tool which locates into the key way of the orienting sub. The survey tool can then be properly aligned with the bent sub.

M.W.D. abbr : Measurement While Drilling. A method of measuring petrophysical properties of formations, drilling parameters (WOB, torque etc.) and environmental parameters downhole and sending the results to surface without interrupting routine drilling operations. A special tool containing sensors, power supply and transmitter is installed as part of the BHA. The information is transmitted to surface by a telemetry system using mud pulses or signals through the pipe.

Nipple n : a short length of tubing (generally less than 12") with male threads at both ends.

Nipple up v : to assemble the components of the BOP stack on the wellhead.

Normal pressure n : the formation pressure which is due to a normal deposition process where the pore fluids are allowed to escape under compaction. The normal pressure gradient is usually taken as 0.465 psi per foot of depth from surface.

Northing n : one of the co-ordinates used in plotting the position of the wellbore in the horizontal plane along the y axis.

Offshore drilling n : drilling for oil or gas from a location which may be in an ocean, gulf, sea or lake. The drilling rig may be on a floating vessel (e.g. semi-submersible, drill ship) or mounted on a platform fixed to the seabed (e.g. jack up, steel jacket).

Oil based mud n : a drilling fluid which contains oil as its continuous phase with only a small amount of water dispersed as droplets.

Open hole n : any wellbore or part of the wellbore which is not supported by casing.

Operator n : the company which carries out an exploration or development programme on a particular area for which they hold a license. The operator may hire a drilling contractor and various service companies to drill wells, and will provide a representative (company man) on the rig.

Orientation v : the process by which a deflection tool is correctly positioned to achieve the intended direction and inclination of the wellbore.

Orienting sub n : a special sub which contains a key or slot, which must be aligned with the scribe line of the bent sub. A surveying instrument can then be run into the sub aligning itself with the key to give the orientation of the scribe line, which defines the tool face.

Overburden n : the layers of rock lying above a particular formation.

Overshot n : a fishing tool which is attached to the drill pipe and is lowered over, and engages, the fish externally.

P **Packed hole assembly** n : a BHA which is designed to maintain hole inclination and direction of the wellbore.

Packer n : a downhole tool, run on drillpipe, tubing or casing, which can be set hydraulically or mechanically against the wellbore. Packers are used extensively in DSTs, cement squeezes and completions.

Pay zone n : the producing formation.

Pendulum assembly n : a BHA which is designed to reduce hole inclination by allowing the drill collars to bend towards the low side of the hole.

Perforate v : to pierce the casing wall and cement, allowing formation fluids to enter the wellbore and flow to surface. This is a critical stage in the completion of a well. Perforating may also be carried out during workover operations.

Perforating gun n : a device fitted with shaped charges which is lowered on wireline to the required depth. When fired electrically from the surface the charges shoot holes in the casing and the tool can then be retrieved.

Permeability n : a measure of the fluid conductivity of a porous medium (i.e. the ability of fluid to flow through the interconnected pores of a rock). The units of permeability are darcies or millidarcies.

pH value n : a parameter which is used to measure the acidity or alkalinity of a substance.

Pilot hole n : a small diameter hole which is later opened up to the required diameter. Sometimes used in directional drilling to control wellbore deviation during kick off.

Pin n : the male section of a threaded connection.

Pipe ram n : a sealing device in a blowout preventor which closes off the annulus around the drill pipe. The size of ram must fit the drillpipe which is being used.

Polycrystalline diamond compact bit (PDC bit) n : a PDC bit is a type of drag bit which uses small discs of man-made diamond as the cutting surface.

P.O.H. abbr : Pull Out of Hole.

Pore n : an opening within a rock which is often filled with formation fluids.



Porosity n : a parameter used to express the pore space within a rock (usually given as a percentage of unit volume).

Positive displacement motor (PDM) n : a drilling tool which is located near the bit and is used to rotate the bit without having to turn the entire drillstring. A spiral rotor is forced to rotate within a rubber sleeved stator by pumping mud through the tool. Sometimes called a “Moineau pump” or “screw drill”.

Pressure gradient n : the variation of pressure with depth. Commonly used under hydrostatic conditions (e.g. a hydrostatic column of salt water has a pressure gradient of 0.465 psi/ft)

Primary cementing n : placing cement around the casing immediately after it has been run into the hole.

Prime mover n : an electric motor or internal combination engine which is the source of power on the drilling rig.

Production casing n : the casing string through which the production tubing and accessories are run to complete the well.

Propping agent n : a granular material carried in suspension by the fracturing fluid which helps to keep the cracks open in the formation after fracture treatment.

Protective casing n : an intermediate string of casing which is run to case off any troublesome zones.

p.s.i. abbr : pounds per square inch. Commonly used unit for expressing pressure.

Pup joint n : a short section of pipe used to space out casing or tubing to reach the correct landing depths.

Rathole n :

1. A hole in the rig floor 30'-60' deep and lined with pipe. It is used for storing the kelly while tripping.
2. That part of the wellbore which is below the bottom of the casing or completion zone.

R

Reactive torque n : the tendency of the drillstring to turn in the opposite direction from that of the bit. This effect must be considered when setting the toolface in directional drilling.

Ream v : to enlarge the wellbore by drilling it again with a special bit.

Reamer n : a tool used in a BHA to stabilise the bit, remove dog legs or enlarge the hole size.

Reeve v : to pass the drilling line through the sheaves of the travelling block and crown block and onto the hoisting drum.

Relief well n : a directionally drilled well whose purpose is to intersect a well which is blowing out, thus enabling the blow out to be controlled.

Reservoir n : a subsurface porous permeable formation in which oil or gas is present.

Reverse circulate v : to pump fluid down the annulus and up the drillstring or tubing back to surface.

Rig n : the derrick, drawworks, rotary table and all associated equipment required to drill a well.

R.I.H. abbr : Run In Hole.

Riser tensioner n : a pneumatic or hydraulic device used to provide a constant strain in the cables which support the marine riser.

R.K.B. abbr : Rotary Kelly Bushing. Term used to indicate the reference point for measuring depths.

Roller cone bit n : a drilling bit with 2 or more cones mounted on bearings. The cutters consist of rows of steel teeth or tungsten carbide inserts. Also called a “rock bit”.

R.O.P. abbr : rate of penetration, normally measured in feet drilled per hour.

Rotary hose n : a reinforced flexible tube which conducts drilling fluid from the standpipe to the swivel. Also called "kelly hose" or “mud hose”.

Rotary table n : the main component of the rotating machine which turns the drillstring. It has a bevelled gear mechanism to create the rotation and an opening into which bushings are fitted.

Roughneck n : an employee of a drilling contractor who works on the drill floor under the direction of the driller.

Round trip v : the process by which the entire drillstring is pulled out the hole and run back in again (usually to change the bit or BHA).

Roustabout n : an employee of the drilling contractor who carries out general labouring work on the rig.

R.P.M. abbr : revolutions per minute. Term used to measure the speed at which the drillstring is rotating.



Safety joint n : a tool which is often run just above a fishing tool. If the fishing tool has gripped the fish but cannot pull it free the safety joint will allow the string to disengage by turning it from surface.

Salt dome n : an anticlinal structure which is caused by an intrusion of rock salt into overlying sediments. This structure is often associated with traps for petroleum accumulations.

Sand n : an abrasive material composed of small quartz grains. The particles range in size from 1/16mm to 2mm. The term is also applied to sandstone.

Sandline n : small diameter wire on which light-weight tools can be lowered down the hole (e.g. surveying instruments).

Scratcher n : a device fastened to the outside of the casing which removes mud cake and thus promote a good cement job.

Semi-submersible n : a floating drilling rig which has submerged hulls, but not resting on the seabed.

Shale n : a fine-grained sedimentary rock composed of silt and clay sized particles.

Shale shaker n : a series of trays with vibrating screens which allow the mud to pass through but retain the cuttings. The mesh must be chosen carefully to match the size of the solids in the mud.

Shear ram n : the component of the BOP stack which cuts through the drillpipe and forms a seal across the top of the wellbore.

Sheave n : (pronounced “shiv”) a grooved pulley.

Sidetrack v : to drill around some permanent obstruction in the hole with some kind of deflecting tool.

Single n : one joint of pipe.

Slips n : wedge-shaped pieces of metal with a gripping element used to suspend the drillstring in the rotary table.

Slug n : a heavy viscous quantity of mud which is pumped into the drillstring prior to pulling out. The slug will cause the level of fluid in the pipe to fall, thus eliminating the loss of mud on the rig floor when connections are broken.

Slurry (cement) n : a pumpable mixture of cement and water. Once in position the slurry hardens and provides an impermeable seal in the annulus and supports the casing.

Spear n : a fishing tool which engages the fish internally and is used to recover stuck pipe.

Specific gravity n : the ratio of the weight of a substance to the weight of the same volume of water.

S.P.M. abbr : Strokes Per Minute. Rate of reciprocation of a Mud Pump.

Spool n : a wellhead component which is used for suspending a string of casing. The spool also has side outlets for allowing access to the annulus between casing strings.

Spud v : to commence drilling operations.

Squeeze cementing v : the process by which cement slurry is forced into place in order to carry out remedial work (e.g. shut off water producing zones, repair casing leaks).

Stab v : to guide the pin end of a pipe into the tool joint or coupling before making up the connection.

Stabbing board n : a temporary platform erected in the derrick 20'-40' above the drill floor. While running casing one man stands on this board to guide the joints into the string suspended on the rig floor.

Stabiliser n : a component placed in the BHA to control the deviation of the wellbore. One or more stabilisers may be used to achieve the intended well path.

Stage collar n : a tool made up in the casing string which is used in the second stage of a primary cement job. The collar has side ports which are opened by dropping a dart from surface. Cement can then be displaced from the casing into the annulus. Also called a "DV collar".

Stand n : three joints of pipe connected together, usually racked in the derrick.

Standpipe n : a heavy wall pipe attached to one of the legs of the derrick. It conducts high pressure mud from the pumps to the rotary hose.

Standpipe manifold n : a series of lines, gauges and valves used for routing mud from the pumps to the standpipe.

Steering tool n : surveying instrument used in conjunction with a mud motor to continuously monitor azimuth, inclination and toolface. - These measurements are relayed to surface via conductor line, and shown on a rig floor display.

Stimulation n : a process undertaken to improve the productivity of a formation by fracturing or acidising.

Stripping v : movement of pipe through closed BOPs.

Stuck pipe n : drillpipe, collars, casing or tubing which cannot be pulled free from the wellbore.



Sub n : a short threaded piece of pipe used as a crossover between pipes of different thread or size. Subs may also have special uses (e.g. bent subs, lifting subs, kelly saver sub).

Subsea wellhead n : the equipment installed on the seabed for suspending casing strings when drilling from a floater.

Suction pit n : the mud pit from which mud is drawn into the mud pumps for circulating down the hole.

Surface casing n : a string of casing set in a wellbore to case off any fresh water sands at shallow depths. Surface casing is run below the conductor pipe to depth of 1000'-4000' depending on particular requirements).

Surge pressures n : excess pressure exerted against the formation due to rapid downward movement of the drillstring when tripping.

Survey v : to measure the inclination and direction of the wellbore at a particular depth.

Survey interval n : the measured depth between survey stations.

Survey station n : the point at which a survey is taken.

Swabbing n : a temporary lowering of the hydrostatic head due to pulling pipe out of the hole.

Swivel n : a component which is suspended from the hook. It allows mud to flow from the rotary hose through the swivel to the kelly while the drillstring is rotating.

Syncline n : a trough-shaped, folded structure of stratified rock.

Target n : the objective defined by the geologist which the well must reach.

Target area n : a specified zone around the target which the well must intersect.

Target bearing n : the direction of the straight line passing through the target and the reference point on the rig. This is used as the reference direction for calculating vertical section.

T.D. abbr : Total Depth.

Telescopic joint n : a component installed at the top of the marine riser to accommodate vertical movement of the floating drilling rig.

Thread protectors n : a device made of metal or plastic which is screwed onto pipe threads to prevent damage during transport or movement around the rig.

Tight formation n : a formation which has low porosity and permeability.

Tongs n : the large wrenches used to connect and disconnect sections of pipe. The tongs have jaws which grip the pipe and torque is applied by pulling manually or mechanically using the cathead. Power tongs are pneumatically or hydraulically operated tools which spin the pipe.

Tool face n : the part of the deflection tool which determines the direction in which deflection will take place. When using a bent sub the tool face is defined by the scribe line.

Tool joint n : a heavy coupling device welded onto the ends of drill pipe. Tool joints have coarse tapered threads to withstand the strain of making and breaking connections and to provide a seal. They also have seating shoulders designed to suspend the weight of the drillstring when the slips are set. On the lower end the pin connection is stabbed into the box of the previous joint. Hardfacing is often applied in a band on the outside of the tool joint to resist abrasion.

Toolpusher n : an employee of the drilling contractor who is responsible for the drilling rig and the crew. Also called rig superintendent.

Torque n : the turning force which is applied to the drillstring causing it to rotate. Torque is usually measured in ft-lbs.

Tour n : (pronounced “tower”) an 8 hour or 12 hour shift worked by the drilling crew.

Trajectory n : the path of the wellbore.

Trap n : the geological structure in which petroleum reserves may have accumulated.

Travelling block n : an arrangement of pulleys through which the drilling line is reeved, thereby allowing the drillstring to be raised or lowered.

Trip v : to pull the drillstring out of the hole, or to run in back in.

Trip gas n : a volume of gas (usually a small amount) which enters the wellbore while making a trip.

Triplex pump n : a reciprocating mud pump with three pistons which are single acting.

True North n : the direction of a line joining any point with the geographical North pole. Corresponds with an azimuth of 000°.

Tugger line n : a small diameter cable wound on an air operated winch which can be used to pick up small loads around the rig floor.

Turbodrill n : a drilling tool located just above the bit which rotates the bit without



turning the drillstring. The tool consists of a series of steel bladed rotors which are turned by the flow of drilling fluid through the tool.

T.V.D. abbr : True Vertical Depth. One of the co-ordinates used to plot the wellpath on the vertical plane.

Twist off v : to sever the drillstring due to excessive force being applied at the rotary table.

Underground blow out v : this situation arises when lost circulation and a kick occur simultaneously. Formation fluids are therefore able to enter the wellbore at the active zone and escape through an upper zone which has been broken down. (Sometimes called an "internal blow out")

Under ream v : to enlarge the size of the wellbore below casing.

Upset n : the section at the ends of tubular goods where the OD is increased to give better strength.

Valve n : a device used to control or shut off completely, the rate of fluid flow along a pipe. Various types of valve are used in drilling equipment.

V door n : an opening in one side of the derrick opposite the drawworks. This opening is used to bring in pipe and other equipment onto the drill floor.

Vertical section n : the horizontal distance obtained by projecting the closure onto the target bearing. This is one of the co-ordinates used in plotting the wellpath on the vertical plane of the proposed wellpath.

Viscometer n : a device used to measure the viscosity of the drilling fluid.

Viscosity n : a measure of a fluid's resistance to flow. The resistance is due to internal friction from the combined effects of cohesion and adhesion.

Vug n : geological term for a cavity in a rock (especially limestone).

Washout n :

1. Wellbore enlargement due to solvent or erosion action of the drilling fluid.
2. A leak in the drillstring due to abrasive mud or mechanical failure.

Water back v : to reduce the weight and solids content of the mud by adding water. This is usually carried out prior to mud treatment.

Water based mud n : a drilling fluid in which the continuous phase is water. Various additives will also be present.

Water injector n : a well which is used to pump water into the reservoir to promote better recovery of hydrocarbons.

Wear bushing n : a piece of equipment installed in the wellhead which is designed to act as a bit guide, casing seat protector and prevent damage to the casing hanger already in place. The wear bushing must be removed before the next casing string is run.

Weight indicator n : an instrument mounted on the driller's console which gives both the weight on bit and the hook load.

Wellbore n : a general term to describe both cased hole and open hole.

Wellhead n : the equipment installed at the top of the wellbore from which casing and tubing strings are suspended.

Whipstock n : a long wedge-shaped pipe that uses an inclined plane to cause the bit to deflect away from its original position.

Wildcat n : an exploration well drilled in an area where no oil or gas has been produced.

Wiper trip n : the process by which the drill bit is pulled back inside the previous casing shoe and then run back to bottom. This may be necessary to improve the condition of the wellbore (e.g. smooth out any irregularities or dog legs which could cause stuck pipe later).

Wireline n : small diameter steel wire which is used to run certain tools down into the wellbore. Also called slick line. Logging tools and perforating guns require conductor line.

W.O.B. abbr : Weight On Bit. The load put on the bit by the drill collars to improve penetration rate.

W.O.C. abbr : Waiting On Cement. The time during which drilling operations are suspended to allow the cement to harden before drilling out the casing shoe.

W.O.W. abbr : Waiting On Weather. The time during which drilling operations must stop due to rough weather conditions. Usually applied to offshore drilling.

Workover n : the carrying out of maintenance and remedial work on the wellbore to increase production.

Overview of Drilling Operations **1**

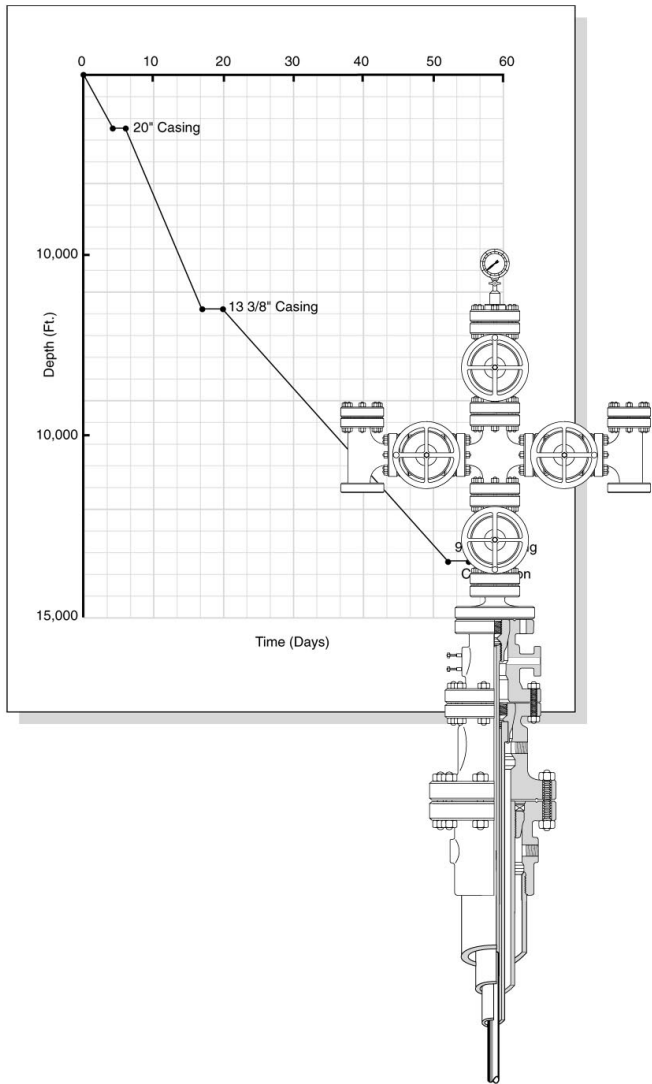

CONTENTS

1. INTRODUCTION
 - 1.1 Exploration and Production Licences
 - 1.2 Exploration, Development and Abandonment
2. DRILLING PERSONNEL
3. THE DRILLING PROPOSAL AND DRILLING PROGRAM
4. ROTARY DRILLING EQUIPMENT
5. THE DRILLING PROCESS
6. OFFSHORE DRILLING
7. DRILLING ECONOMICS
 - 7.1 Drilling Costs in Field Development
 - 7.2 Drilling Cost Estimates





LEARNING OBJECTIVES:

Having worked through this chapter the student will be able to:

Exploration, Appraisal and Development:

- Describe the role of drilling in the exploration, appraisal and development of a field.
- Describe the types of information gathered during the drilling of a well.
- Define the objectives of an exploration, appraisal and development well.
- Describe the licensing process for an exploration, appraisal and development well.

Personnel:

- Describe the organisations and people, and their respective responsibilities, involved in drilling a well.
- Describe the differences between a day-rate and turnkey drilling contract.

Drilling and Completing a Well:

- Describe the steps involved in Drilling and Completing a well, highlighting the reasons behind each step in the operation.

Drilling Economics :

- Identify the major cost elements when drilling a well
- Identify the major time consuming operations when drilling a well.

1. INTRODUCTION

1.1 Exploration and Production Licences :

In the United Kingdom, the secretary of State for Energy is empowered, on behalf of the Government, to invite companies to apply for **exploration** and **production licences** on the **United Kingdom Continental Shelf** (UKCS). Exploration licences may be awarded at any time but Production licences are awarded at specific discrete intervals known as licencing 'Rounds'. Exploration licences do not allow a company to drill any deeper than 350 metres (1148ft.) and are used primarily to enable a company to acquire seismic data from a given area, since a well drilled to 1148 ft on the UKCS would not yield a great deal of information about potential reservoirs.

Production licences allow the licensee to drill for, develop and produce hydrocarbons from whatever depth is necessary. The cost of field development in the North Sea are so great that major oil companies have formed partnerships, known as **joint ventures**, to share these exploration and development costs (e.g. Shell/Esso).

1.2 Exploration, Development and Abandonment:

Before drilling an **exploration well** an oil company will have to obtain a production licence. Prior to applying for a production licence however the exploration geologists will conduct a '**scouting**' exercise in which they will analyse any seismic data they have acquired, analyse the regional geology of the area and finally take into account any available information on nearby producing fields or well tests performed in the vicinity of the prospect they are considering. The explorationists in the company will also consider the exploration and development costs, the oil price and tax regimes in order to establish whether, if a discovery were made, it would be worth developing.

If the prospect is considered worth exploring further the company will try to acquire a production licence and continue exploring the field. This licence will allow the company to drill exploration wells in the area of interest. It will in fact commit the company to drill one or more wells in the area. The licence may be acquired by an oil company directly from the government, during the licence rounds are announced, or at any other time by **farming-into** an existing licence. A farm-in involves the company taking over all or part of a licence either: by paying a sum of money to the licensee; by drilling the committed wells on behalf of the licensee, at its own expense; or by acquiring the company who owns the licence.

Before the exploration wells are drilled the licensee may shoot extra seismic lines, in a closer grid pattern than it had done previously. This will provide more detailed information about the prospect and will assist in the definition of an optimum drilling target. Despite improvements in seismic techniques the only way of confirming the presence of hydrocarbons is to drill an exploration well. Drilling is very expensive, and if hydrocarbons are not found there is no return on the investment, although valuable geological information may be obtained. With only limited information available a large risk is involved. Having decided to go ahead and drill an exploration well proposal is prepared. The objectives of this well will be:

- To determine the presence of hydrocarbons
- To provide geological data (cores, logs) for evaluation
- To flow test the well to determine its production potential, and obtain fluid samples.

The life of an oil or gas field can be sub-divided into the following phases:

- Exploration
- Appraisal
- Development
- Maintenance
- Abandonment

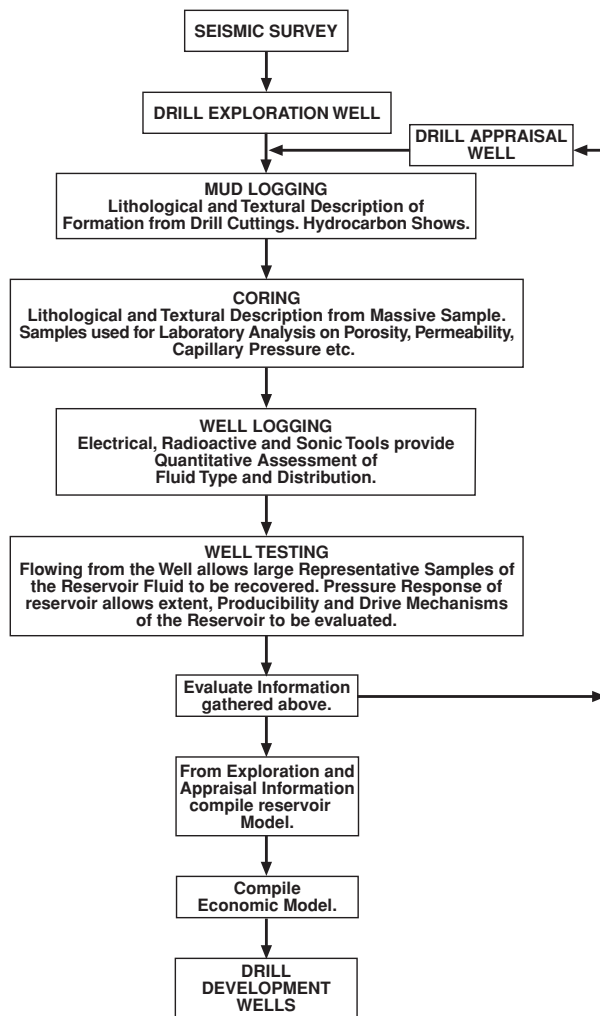

Figure 1 Role of drilling in field development

The length of the **exploration** phase will depend on the success or otherwise of the exploration wells. There may be a single exploration well or many exploration wells drilled on a prospect. If an economically attractive discovery is made on the prospect then the company enters the **Appraisal** phase of the life of the field. During this phase more seismic lines may be shot and more wells will be drilled to establish the lateral and vertical extent of (to **delineate**) the reservoir. These **appraisal wells** will yield further information, on the basis of which future plans will be based. The information provided by the appraisal wells will be combined with all of the previously collected data and engineers will investigate the most cost effective manner in which to develop the field. If the prospect is deemed to be economically attractive a **Field Development Plan** will be submitted for approval to the Secretary of State for Energy. It must be noted that the oil company is only a licensee and that the oilfield is the property of the state. The state must therefore approve any plans for development of the field. If approval for the development is received then the company will commence drilling **Development wells** and constructing the production facilities according to the Development Plan. Once the field is 'on-stream' the companies' commitment continues in the form of **maintenance** of both the wells and all of the production facilities.

After many years of production it may be found that the field is yielding more or possibly less hydrocarbons than initially anticipated at the Development Planning stage and the company may undertake further appraisal and subsequent drilling in the field.

At some point in the life of the field the costs of production will exceed the revenue from the field and the field will be **abandoned**. All of the wells will be plugged and the surface facilities will have to be removed in a safe and environmentally acceptable fashion.

2. DRILLING PERSONNEL

Drilling a well requires many different skills and involves many companies (Figure 2). The oil company who manages the drilling and/or production operations is known as the **operator**. In joint ventures one company acts as operator on behalf of the other partners.

There are many different management strategies for drilling a well but in virtually all cases the oil company will employ a **drilling contractor** to actually drill the well. The drilling contractor owns and maintains the drilling rig and employs and trains the personnel required to operate the rig. During the course of drilling the well certain specialised skills or equipment may be required (e.g. logging, surveying). These are provided by **service companies**. These service companies develop and maintain specialist tools and staff and hire them out to the operator, generally on a day-rate basis.

The contracting strategies for drilling a well or wells range from **day-rate contracts** to **turnkey contracts**. The most common type of drilling contract is a **day-rate contract**. In the case of the **day-rate contract** the operator prepares a detailed well design and program of work for the drilling operation and the drilling contractor



simply provides the drilling rig and personnel to drill the well. The contractor is paid a fixed sum of money for every day that he spends drilling the well. All consumable items (e.g. drilling bits, cement), transport and support services are provided by the operator.

In the case of the **turnkey contract** the drilling contractor designs the well, contracts the transport and support services and purchases all of the consumables, and charges the oil company a fixed sum of money for whole operation. The role of the operator in the case of a turnkey contract is to specify the drilling targets, the evaluation procedures and to establish the quality controls on the final well. In all cases the drilling contractor is responsible for maintaining the rig and the associated equipment.

The operator will generally have a representative on the rig (sometimes called the “**company man**”) to ensure drilling operations go ahead as planned, make decisions affecting progress of the well, and organise supplies of equipment. He will be in daily contact with his **drilling superintendent** who will be based in the head office of the operator. There may also be an oil company **drilling engineer** and/or a **geologist** on the rig.

The drilling contractor will employ a **toolpusher** to be in overall charge of the rig. He is responsible for all rig floor activities and liaises with the company man to ensure progress is satisfactory. The manual activities associated with drilling the well are conducted by the drilling crew. Since drilling continues 24 hours a day, there are usually 2 drilling crews. Each crew works under the direction of the **driller**. The crew will generally consist of a **derrickman** (who also tends the pumps while drilling), 3 **roughnecks** (working on rig floor), plus a mechanic, an electrician, a crane operator and **roustabouts** (general labourers).

Service company personnel are transported to the rig as and when required. Sometimes they are on the rig for the entire well (e.g. mud engineer) or only for a few days during particular operations (e.g. directional drilling engineer).

An overall view of the personnel involved in drilling is shown in Figure 2.

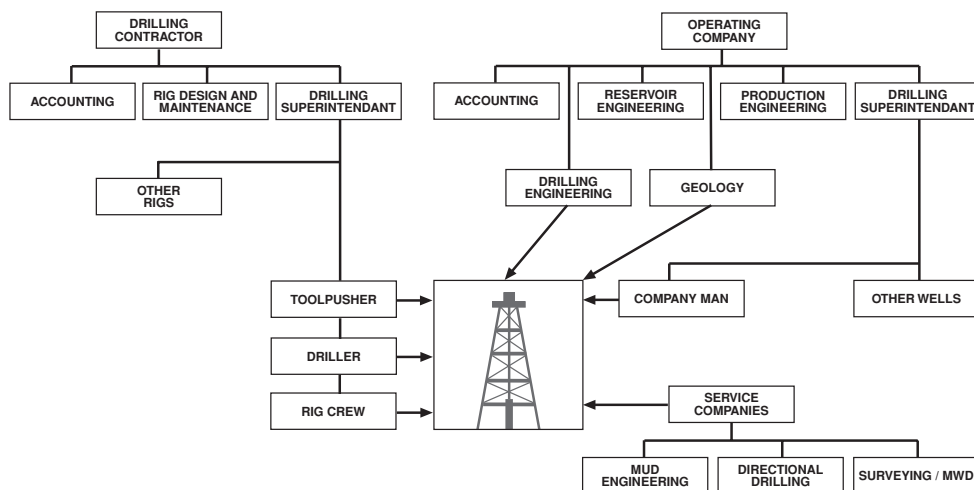

Figure 2 Personnel involved in drilling a well

3. THE DRILLING PROPOSAL AND DRILLING PROGRAM

The **proposal** for drilling the well is prepared by the geologists and reservoir engineers in the operating company and provides the information upon which the well will be designed and the **drilling program** will be prepared. The proposal contains the following information:

- Objective of the Well
- Depth (m/ft Subsea), and Location (Longitude and Latitude) of Target
- Geological Cross section
- Pore Pressure Profile Prediction

The drilling program is prepared by the Drilling Engineer and contains the following:

- Drilling Rig to be used for the well
- Proposed Location for the Drilling Rig
- Hole Sizes and Depths
- Casing Sizes and Depths
- Drilling Fluid Specification
- Directional Drilling Information
- Well Control Equipment and Procedures
- Bits and Hydraulics Program

4. ROTARY DRILLING EQUIPMENT

The first planned oilwell was drilled in 1859 by Colonel Drake at Titusville, Pennsylvania USA. This well was less than 100 ft deep and produced about 50 bbls/day. The **cable-tool drilling** method was used to drill this first well. The term cable-tool drilling is used to describe the technique in which a chisel is suspended from the end of a wire cable and is made to impact repeatedly on the bottom of the hole, chipping away at the formation. When the rock at the bottom of the hole has been disintegrated, water is poured down the hole and a long cylindrical bucket (bailer) is run down the hole to collect the chips of rock. Cable-tool drilling was used up until the 1930s to reach depths of 7500 ft.

In the 1890s the first **rotary drilling rigs** (Figure 3) were introduced. Rotary drilling rigs will be described in detail in the next chapter but essentially rotary drilling is the technique whereby the rock cutting tool is suspended on the end of hollow pipe, so that fluid can be continuously circulated across the face of the drillbit cleaning the drilling material from the face of the bit and carrying it to surface. This is a much more efficient process than the cable-tool technique. The cutting tool used in this type of drilling is not a chisel but a relatively complex tool (**drillbit**) which drills through the rock under the combined effect of axial load and rotation and will be described in detail in the chapter relating to drillbits. The first major success for rotary drilling was at Spindletop, Texas in 1901 where oil was discovered at 1020 ft and produced about 100,000 bbl/day.

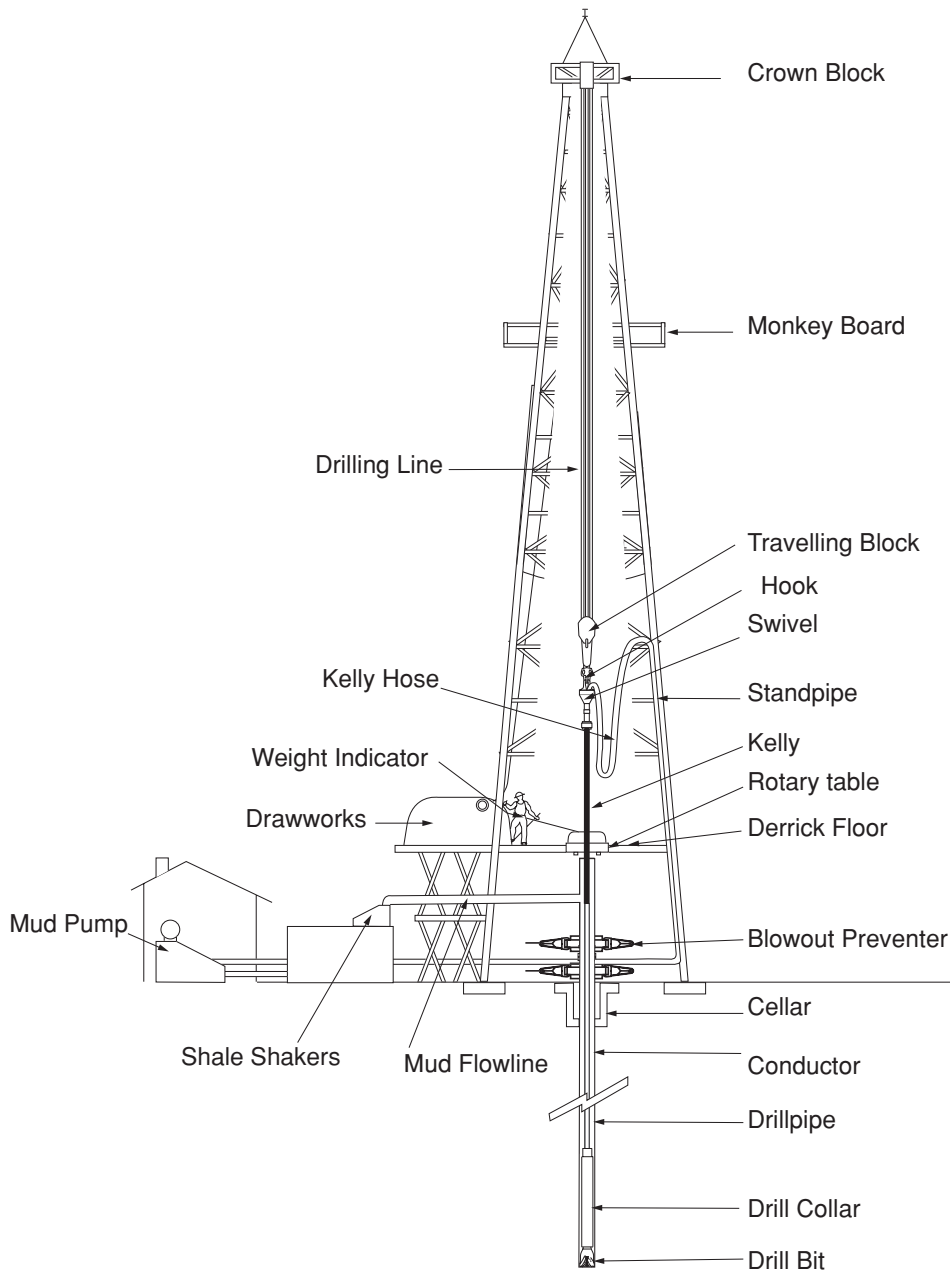

Figure 3 Drilling rig components

5. THE DRILLING PROCESS

The operations involved in drilling a well can be best illustrated by considering the sequence of events involved in drilling the well shown in Figure 4. The dimensions (depths and diameters) used in this example are typical of those found in the North Sea but could be different in other parts of the world. For simplicity the process of drilling a land well will be considered below. The process of drilling a subsea well will be considered in a later chapter.

The following description is only an overview of the process of drilling a well (**the construction process**). The design of the well, selection of equipment and operations involved in each step will be dealt with in greater depth in subsequent chapters of this manual.

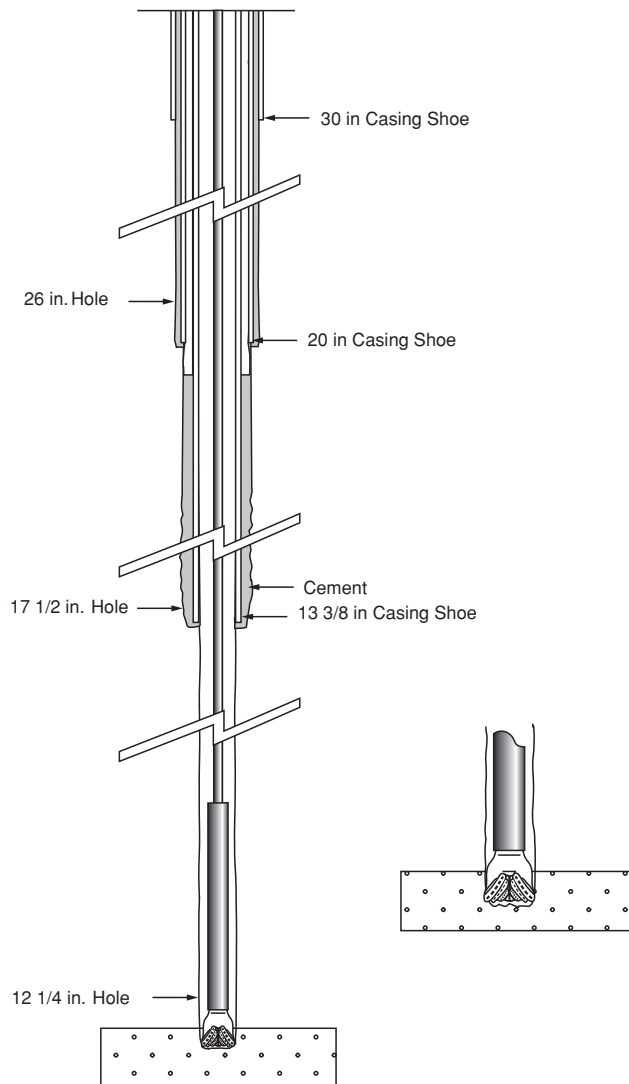

Figure 4 Typical hole and casing sizes

Installing the 30" Conductor:

The first stage in the operation is to drive a large diameter pipe to a depth of approximately 100ft below ground level using a truck mounted pile-driver. This pipe (usually called **casing** or, in the case of the first pipe installed, **the conductor**) is installed to prevent the unconsolidated surface formations from collapsing whilst drilling deeper. Once this conductor, which typically has an outside diameter (**O. D.**) of 30" is in place the full sized drilling rig is brought onto the site and set up over the conductor, and preparations are made for the next stage of the operation.



Drilling and Casing the 26" Hole:

The first hole section is drilled with a drillbit, which has a smaller diameter than the inner diameter (I.D.) of the conductor. Since the I.D. of the conductor is approximately 28", a 26" diameter bit is generally used for this hole section. This 26" hole will be drilled down through the unconsolidated formations, near surface, to approximately 2000'.

If possible, the entire well, from surface to the reservoir would be drilled in one hole section. However, this is generally not possible because of geological and formation pressure problems which are encountered whilst drilling. The well is therefore drilled in sections, with casing being used to isolate the problem formations once they have been penetrated. This means however that the wellbore diameter gets smaller and smaller as the well goes deeper and deeper. The drilling engineer must assess the risk of encountering these problems, on the basis of the geological and formation pressure information provided by the geologists and reservoir engineers, and drilling experience in the area. The well will then be designed such that the dimensions of the borehole that penetrates the reservoir, and the casing that is set across the reservoir, will allow the well to be produced in the most efficient manner possible. In the case of an exploration well the final borehole diameter must be large enough to allow the reservoir to be fully evaluated.

Whilst drilling the 26" hole, drilling fluid (**mud**) is circulated down the drillpipe, across the face of the drillbit, and up the annulus between the drillpipe and the borehole, carrying the **drilled cuttings** from the face of the bit to surface. At surface the cuttings are removed from the mud before it is circulated back down the drillpipe, to collect more cuttings.

When the drillbit reaches approximately 2000' the drillstring is pulled out of the hole and another string of pipe (**surface casing**) is run into the hole. This casing, which is generally 20" O.D., is delivered to the rig in 40ft lengths (**joints**) with threaded connections at either end of each joint. The casing is lowered into the hole, joint by joint, until it reaches the bottom of the hole. Cement slurry is then pumped into the annular space between the casing and the borehole. This cement sheath acts as a seal between the casing and the borehole, preventing cavings from falling down through the annular space between the casing and hole, into the subsequent hole and/or fluids flowing from the next hole section up into this annular space.

Drilling and Casing the 17 1/2" Hole:

Once the cement has set hard, a large *spool* called a **wellhead housing** is attached to the top of the 20" casing. This wellhead housing is used to support the weight of subsequent casing strings and the annular valves known as the **Blowout prevention (BOP) stack** which must be placed on top of the casing before the next hole section is drilled.

Since it is possible that formations containing fluids under high pressure will be encountered whilst drilling the next (17 1/2") hole section a set of valves, known as a Blowout prevention (BOP) stack, is generally fitted to the wellhead before the 17 1/2" hole section is started. If high pressure fluids are encountered they will displace the drilling mud and, if the BOP stack were not in place, would flow in an

uncontrolled manner to surface. This uncontrolled flow of hydrocarbons is termed a **Blowout** and hence the title **Blowout Preventers (BOP's)**. The BOP valves are designed to close around the drillpipe, sealing off the annular space between the drillpipe and the casing. These BOPS have a large I.D. so that all of the necessary drilling tools can be run in hole.

When the BOP's have been installed and pressure tested, a 17 1/2" hole is drilled down to 6000 ft. Once this depth has been reached the troublesome formations in the 17 1/2" hole are isolated behind another string of casing (13 5/8" **intermediate casing**). This casing is run into the hole in the same way as the 20" casing and is supported by the 20" wellhead housing whilst it is cemented in place.

When the cement has set hard the BOP stack is removed and a **wellhead spool** is mounted on top of the wellhead housing. The wellhead spool performs the same function as a wellhead housing except that the wellhead spool has a spool connection on its upper and lower end whereas the wellhead housing has a threaded or welded connection on its lower end and a spool connection on its upper end. This wellhead spool supports the weight of the next string of casing and the BOP stack which is required for the next hole section.

Drilling and Casing the 12 1/4" Hole:

When the BOP has been re-installed and pressure tested a 12 1/4" hole is drilled through the oil bearing reservoir. Whilst drilling through this formation oil will be visible on the cuttings being brought to surface by the drilling fluid. If gas is present in the formation it will also be brought to surface by the drilling fluid and detected by gas detectors placed above the mud flowline connected to the top of the BOP stack. If oil or gas is detected the formation will be evaluated more fully.

The drillstring is pulled out and tools which can measure for instance: the electrical resistance of the fluids in the rock (indicating the presence of water or hydrocarbons); the bulk density of the rock (indicating the porosity of the rocks); or the natural radioactive emissions from the rock (indicating the presence of non-porous shales or porous sands) are run in hole. These tools are run on conductive cable called **electric wireline**, so that the measurements can be transmitted and plotted (against depth) almost immediately at surface. These plots are called **Petrophysical logs** and the tools are therefore called **wireline logging tools**.

In some cases, it may be desirable to retrieve a large cylindrical sample of the rock known as a **core**. In order to do this the conventional bit must be pulled from the borehole when the conventional drillbit is about to enter the oil-bearing sand. A donut shaped bit is then attached a special large diameter pipe known as a **core barrel** is run in hole on the drillpipe.

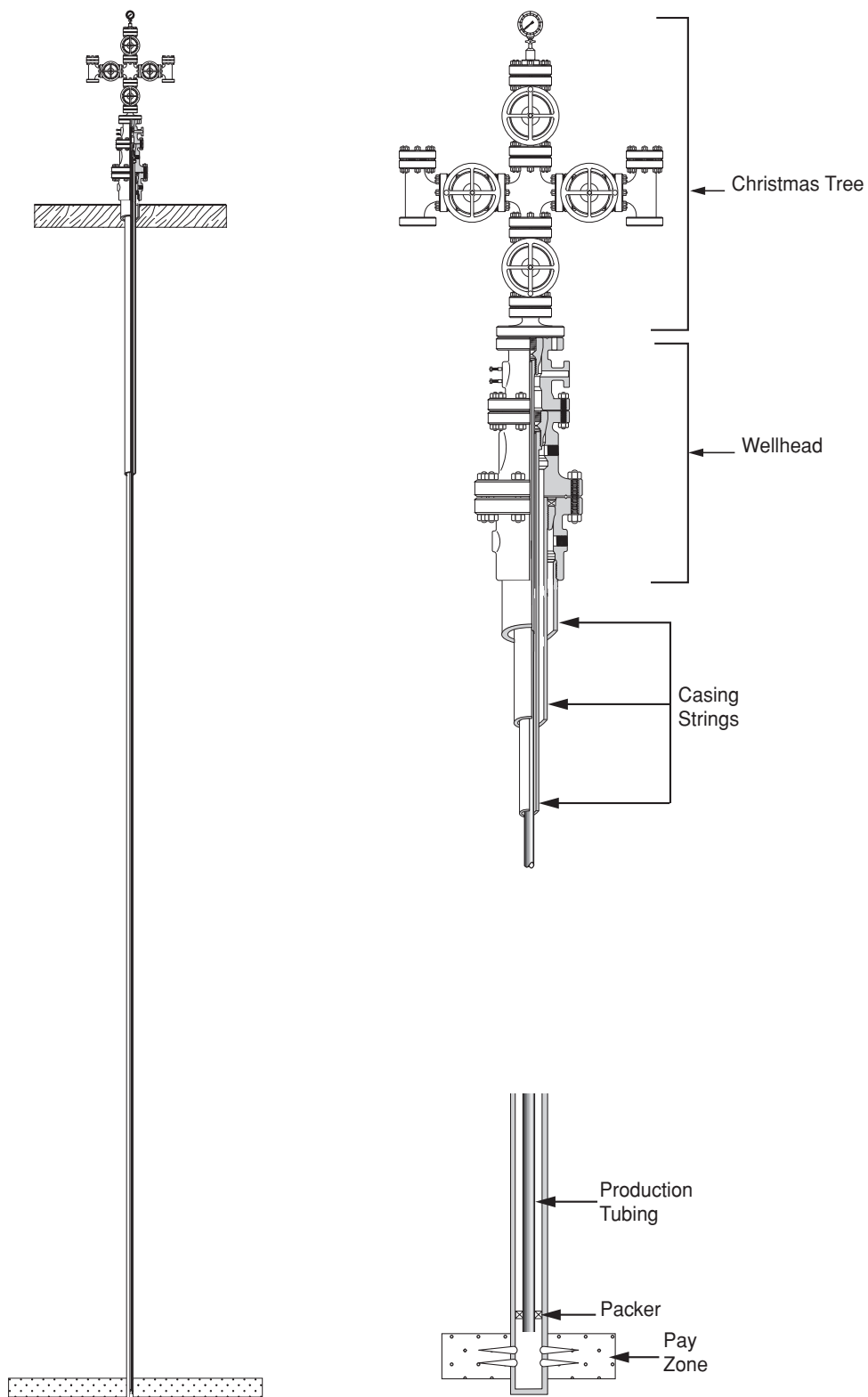

Figure 5 Completion schematic

This coring assembly allows the core to be cut from the rock and retrieved. Porosity and permeability measurements can be conducted on this core sample in the laboratory. In some cases tools will be run in the hole which will allow the hydrocarbons in the sand to flow to surface in a controlled manner. These tools allow the fluid to flow in much the same way as it would when the well is on production. Since the produced fluid is allowed to flow through the drillstring or, as it is sometimes called, the drilling string, this test is termed a **drill-stem test or DST**.

If all the indications from these tests are good then the oil company will decide to **complete the well**. If the tests are negative or show only slight indications of oil, the well will be abandoned.

Completing the Well:

If the well is to be used for long term production, equipment which will allow the controlled flow of the hydrocarbons must be installed in the well. In most cases the first step in this operation is to run and cement **production casing** (9 5/8" O.D.) across the oil producing zone. A string of pipe, known as **tubing** (4 1/2" O.D.), through which the hydrocarbons will flow is then run inside this casing string. The production tubing, unlike the production casing, can be pulled from the well if it develops a leak or corrodes. The annulus between the production casing and the production tubing is sealed off by a device known as a **packer**. This device is run on the bottom of the tubing and is set in place by hydraulic pressure or mechanical manipulation of the tubing string.

When the packer is positioned just above the pay zone its rubber seals are expanded to seal off the annulus between the tubing and the 9 5/8" casing (Figure 5). The BOP's are then removed and a set of valves (**Christmas Tree**) is installed on the top of the wellhead. The Xmas tree is used to control the flow of oil once it reaches the surface. To initiate production, the production casing is "**perforated**" by explosive charges run down the tubing on wireline and positioned adjacent to the pay zone. Holes are then shot through the casing and cement into the formation. The hydrocarbons flow into the wellbore and up the tubing to the surface.

6. OFFSHORE DRILLING

About 25% of the world's oil and gas is currently being produced from offshore fields (e.g. North Sea, Gulf of Mexico). Although the same principles of rotary drilling used onshore are also used offshore there are certain modifications to procedures and equipment which are necessary to cope with a more hostile environment.

In the North Sea, exploration wells are drilled from a **jack-up** (Figure 6) or a **semi-submersible** (Figure 7) drilling rig. A jack-up has retractable legs which can be lowered down to the seabed. The legs support the drilling rig and keep the rig in position (Figure 6). Such rigs are generally designed for water depths of up to 350 ft water depth. A semi-submersible rig is not bottom supported but is designed to float (such rigs are commonly called "floaters"). Semi-submersibles can operate in water depths of up to 3500 ft. (Figure 7). In very deep waters (up to 7500 ft) **drillships** (Figure 8) are used to drill the well. Since the position of floating drilling rigs is constantly changing relative to the seabed special equipment must be used to

connect the rig to the seabed and to allow drilling to proceed. The equipment used to drill wells from these drilling rigs will be discussed at length in a subsequent chapter.

If the exploration wells are successful the field may be developed by installing large fixed platforms from which **deviated wells** are drilled (Figure 9). There may be up to 40 such wells drilled from one platform to cover an entire oilfield. For the very large fields in the North Sea (e.g. Forties, Brent) several platforms may be required. These deviated wells may have horizontal displacements of 10,000 ft and reach an inclination of 70 degrees or more. For smaller fields a fixed platform may not be economically feasible and alternative methods must be used (e.g. floating production system on the Balmoral field). Once the development wells have been drilled the rig still has a lot of work to do. Some wells may require maintenance (workovers) or sidetracks to intersect another part of the reservoir (re-drill). Some wells may be converted from producers to gas injectors or water injectors.

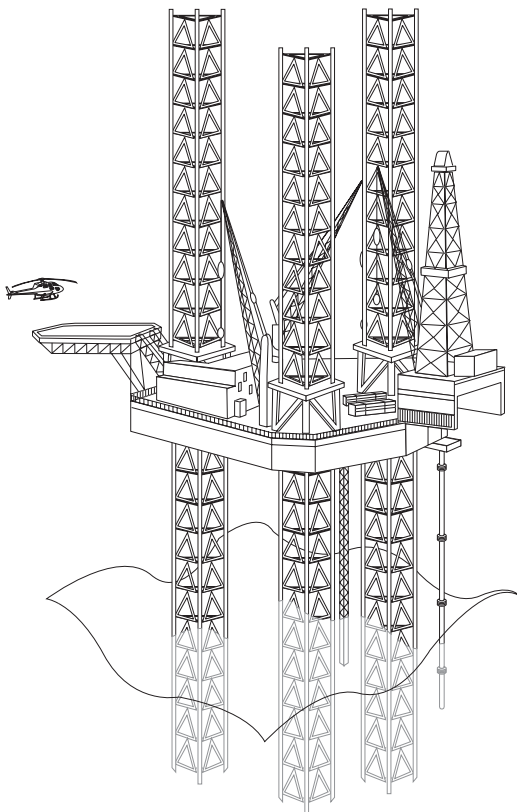

Figure 6 Jack-up rig

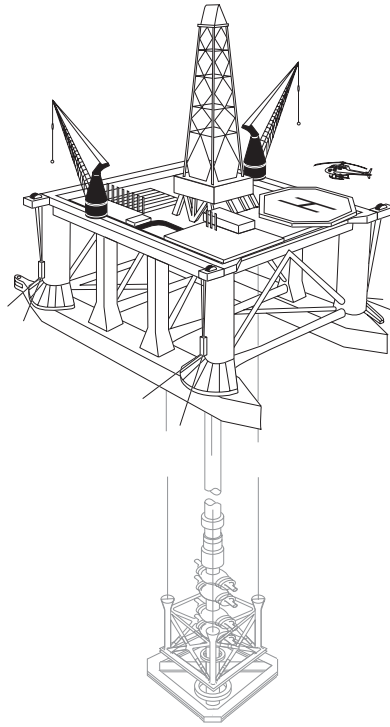

Figure 7 Semi- submersible rig

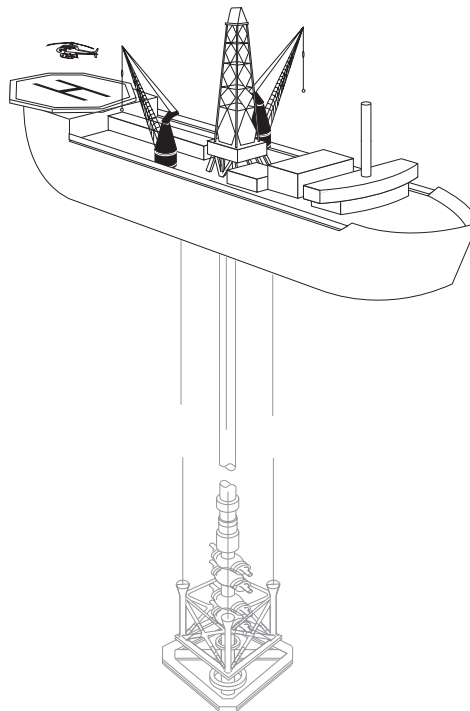

Figure 8 Drillship

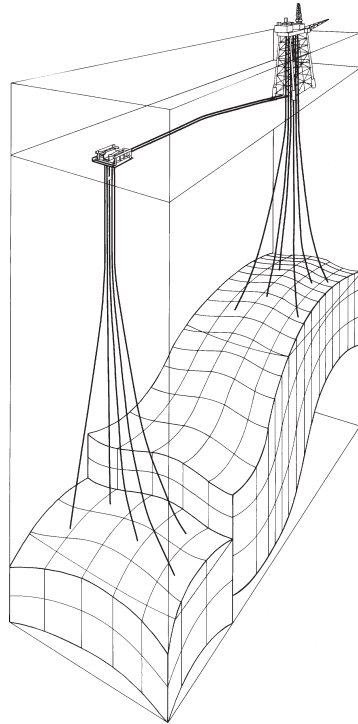

Figure 9 Fixed platform (Steel Jacket)

A well drilled from an offshore rig is much more expensive than a land well drilled to the same depth. The increased cost can be attributed to several factors, e.g. specially designed rigs, subsea equipment, loss of time due to bad weather, expensive transport costs (e.g. helicopters, supply boats). A typical North Sea well drilled from a fixed platform may cost around \$10 million. Since the daily cost of hiring an offshore rig is very high, operating companies are very anxious to reduce the drilling time and thus cut the cost of the well.

7. DRILLING ECONOMICS

7.1 Drilling Costs in Field Development

It is quite common for Drilling costs to make up 25-35% of the total development costs for an offshore oilfield (Table 1). The costs of the development will not be recovered for some time since in most cases production is delayed until the first few platform wells are drilled. These delays can have a serious impact on the economic feasibility of the development and operators are anxious to reduce the lead time to a minimum. the development wells are being drilled.

	Cost (\$ million)
Platform structure	230
Platform equipment	765
Platform installation	210
Development drilling	475
Pipeline	225
Onshore facilities	50
Miscellaneous	120
Total	2075

Table 1 Estimated development costs (Brae field)

7.2 Drilling Cost Estimates

Before a drilling programme is approved it must contain an estimate of the overall costs involved. When drilling in a completely new area with no previous drilling data available the well cost can only be a rough approximation. In most cases however, some previous well data is available and a reasonable approximation can be made.

A typical cost distribution for a North sea Well is Shown in Table 2. Some costs are related to time and are therefore called **time-related costs** (e.g. drilling contract, transport, accommodation). Many of the consumable items (e.g. casing, cement) are related to depth and are therefore often called **depth-related costs**. These costs can be estimated from the drilling programme, which gives the lengths or volumes required. Some of the consumable items such as the wellhead will be a **fixed cost**. The specialised services (e.g. perforating) will be a charged for on the basis of a service contract which will have been agreed before the service is provided. The pricelist associated with this contract will be a function of both time and depth and the payment for the service will be made when the operation has been completed. For wells drilled from the same rig under similar conditions (e.g. platform drilling) the main factor in determining the cost is the depth, and hence the number of days the well is expected to take. Figure 10 shows a plot of depth against days for wells drilled from a North Sea platform. It is interesting to note that of the total time spent drilling a well less than half is spent actually rotating on bottom (Table 3).



Breakdown of Well Costs		
	(\$1000)	(%)
Wellhead	105	1.1
Flowline and surface equipment	161	1.7
Casing and downhole equipment	1465	15.5
Sub- total	1731	18.3
Drilling contractor	2061	21.8
Directional drilling/surveying	319	3.4
Logging/testing/perforating	603	6.4
Mud processing/chemicals	858	9.1
Cementing	288	3.0
Bits	282	3.0
Sub-total	4411	46.7
Transport	1581	16.7
Equipment rental	391	4.1
Communications	120	1.3
Mobilisation	686	7.3
Power and fuel	225	2.4
Supervision	300	3.2
Sub-total	3303	35.0
Total well cost	\$9,445,000	

TABLE 2 Breakdown of well costs

Time breakdown for a North Sea well (fixed platform)		
	HOURS	%
Drill	552.0	41.9
Trips/Lay Down Drill Pipe	195.0	14.8
Directional Surveys	104.0	7.9
Core/Circ. Samples	91.5	6.9
Guide Base/Conductor	60.0	4.6
Wash/Ream/Clean Out Borehole	59.0	4.5
Lost Time	49.5	3.8
Run Casing/Tubing/Packer	37.5	2.8
Nipple down, up/Run Riser	37.0	2.8
Log/Set Packer/Perforate	26.5	2.0
Test Bops/Wellhead	25.0	1.9
Rig Maintenance	20.5	1.6
Circ. & Cond./Displace Mud	20.5	1.5
Fishing/Milling	20.0	1.5
Cement/Squeeze/WOC	18.0	1.4
Rig Down/Move/Rig Up	2.5	0.2
TOTAL	1318.5hrs (55 days)	100.0

Table 3 Time breakdown for a North Sea well (fixed platform)

More sophisticated methods of estimating well costs are available through specially designed computer programmes. Whatever method is used to produce a total cost some allowance must be made for unforeseen problems. When the estimate has been worked out it is submitted to the company management for approval. This is usually known as an AFE (authority for expenditure). Funds are then made available to finance the drilling of the well within a certain budget. When a well exceeds its allocated funds a supplementary AFE must be raised to cover the extra costs.

Exercise 1 Cost and Time Distributions

Rank the major cost elements in the development of the Brae Field given in Table 1 and consider the ways in which the costs distribution might change with a bigger or smaller field.

Consider how the costs associated with a well (Table 2) are related to the time distribution (Table 3) for a well.

Exercise 2 The Drilling Process

You are required to drill a well into the Rotliegende sandstone (ROSL) shown on the attached geological cross section (Appendix 1). Consider the following aspects of the drilling operation and how you would drill the well.:

- a) the rock penetration process
 - the rock cutting mechanism/tool
 - the transmission of energy to the cutting tool
 - the removal of debris from the face of the cutting tool and the borehole
 - b) the stability/integrity of the borehole
 - potential causes of instability
 - potential consequences of instability
 - means of preventing/mitigating problems associated with instability
 - c) the safety of the operation
 - the greatest source of risk during the drilling operation
 - d) data and its acquisition
 - data relevant to the drilling process
 - data relevant to evaluating the potential oil and gas production of the formations
 - e) the surface equipment requirements
-
-

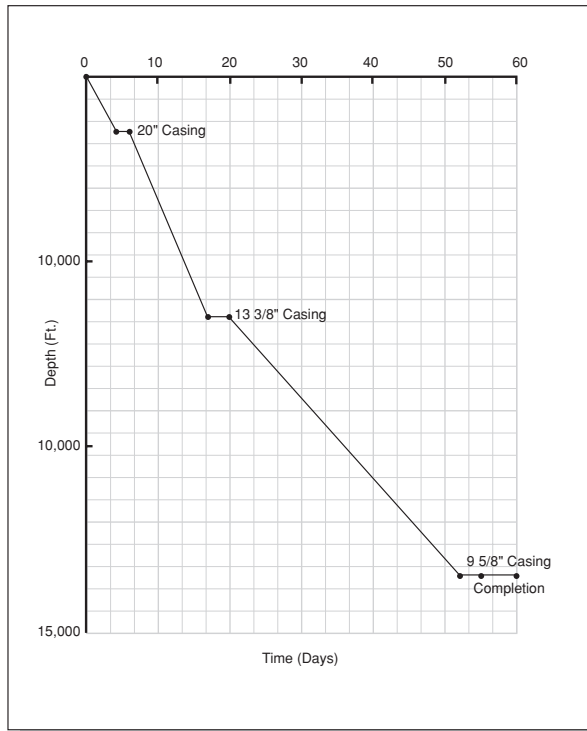
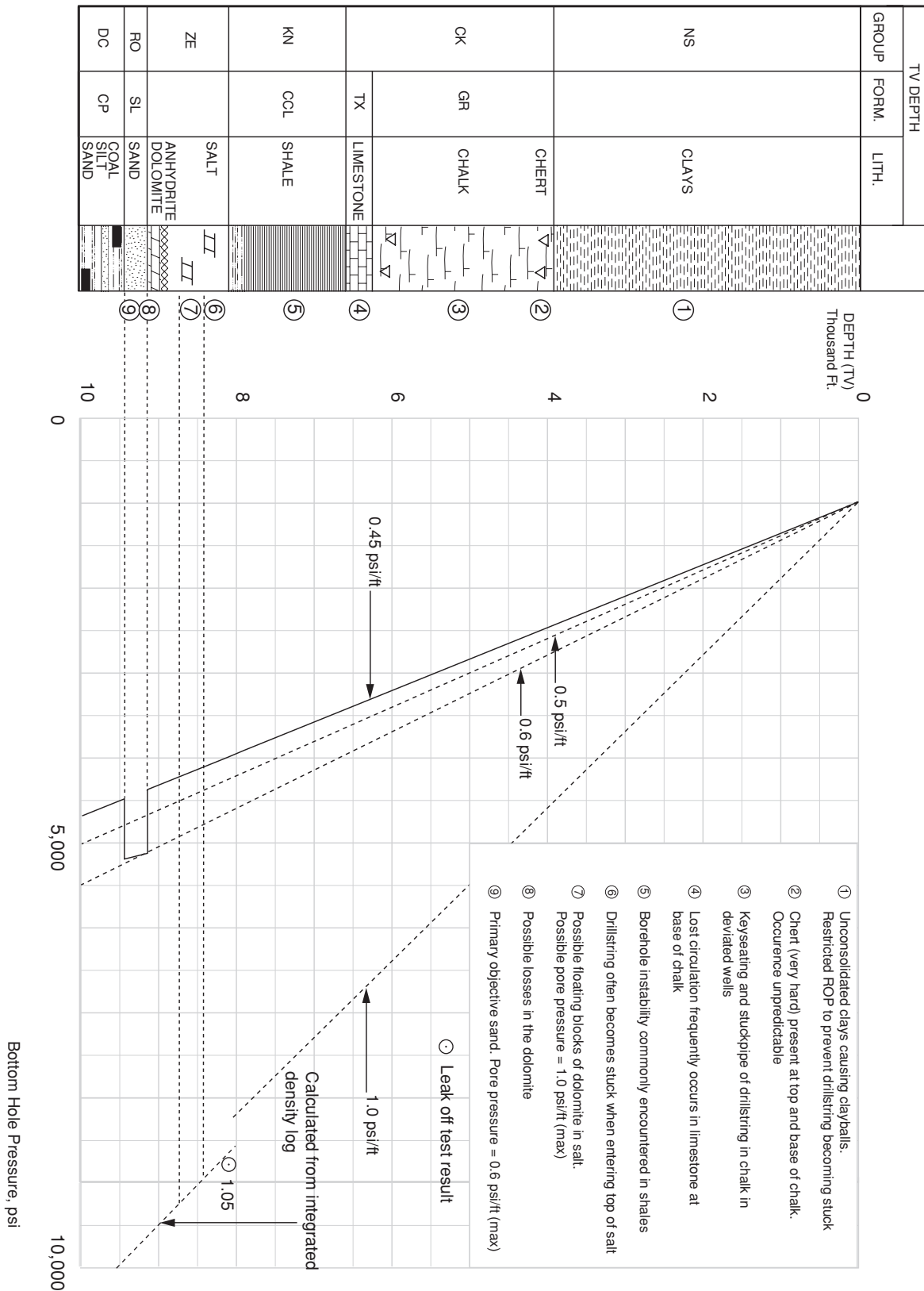
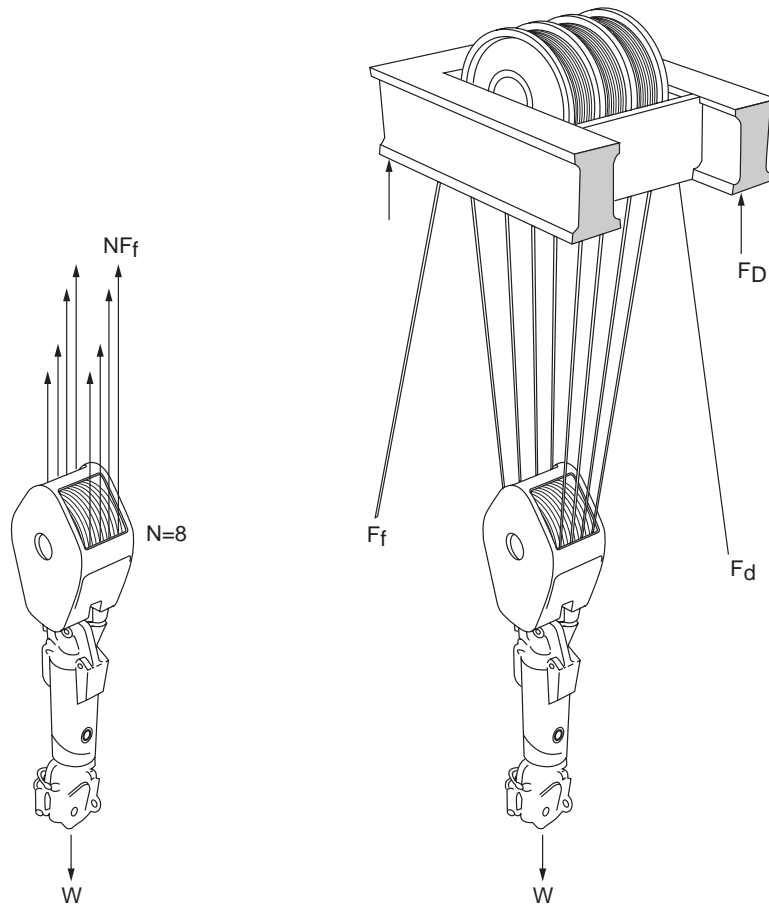

Figure 10 Drilling Time/Depth chart

APPENDIX 1



Rig Components²



(a) Free body diagram of traveling block

(b) Free body diagram of crown block



C O N T E N T S

1. INTRODUCTION

2. POWER SYSTEM

3. CIRCULATING SYSTEM

Round Trip Operations

Drilling Ahead

Running Casing

Short Trips

4. CIRCULATING SYSTEM

Duplex Pumps

Triplex Pumps

5. ROTARY SYSTEM

5.1 Procedure for Adding Drillpipe when
Drilling Ahead

5.2 Procedure for Pulling the Drillstring from the
Hole

5.3 Iron Roughneck

5.4 Top Drive Systems

6. WELL CONTROL SYSTEM

6.1 Detecting a kick

6.2 Closing in the Well

6.3 Circulating out a kick

7. WELL MONITORING SYSTEM



LEARNING OBJECTIVES:

Having worked through this chapter the student will be able to:

General:

- Describe the six major sub-systems of a drilling rig and the function of each system.

Power System:

- Describe the power system on a drilling rig.

Hoisting system:

- Identify the names of each of the component parts of the hoisting system and state its purpose.
- Describe the slip and slip and cut operation.
- Calculate the tension on the drilling line and select an appropriate line diameter for a particular application.
- Calculate the load on the derrick when running or pulling a string or casing or drillpipe.
- Calculate the work done on a drilling line.

Circulating System:

- Describe the functions of the drilling fluid.
- Identify the names of each of the component parts of the circulating system and state its purpose.
- Describe the difference between duplex and triplex pumps.
- Calculate the volumetric output of a triplex and duplex pump.
- Calculate the horsepower requirements for the mud pumps.

Rotary System:

- Identify the names of each of the component parts of the rotary system and state its purpose.
- State the benefits of the topdrive system.
- Describe the procedure for running and pulling out of hole.
- Describe the procedure for making a connection.

Well Control System:

- Identify the names of each of the component parts of the well control system and state its purpose.

Well Monitoring Equipment:

- List and describe the functions which are monitored and the monitoring equipment that would be placed on the rig.

1. INTRODUCTION

There are many individual pieces of equipment on a rotary drilling rig (Figure 1). These individual pieces of equipment can however be grouped together into six sub-systems. These systems are: the power system; the hoisting system; the circulating system; the rotary system; the well control system and the well monitoring system. Although the pieces of equipment associated with these systems will vary in design, these systems will be found on all drilling rigs. The equipment discussed below will be found on both land-based and offshore drilling rigs. The specialised equipment which is required to drill from an offshore drilling rig will be discussed in a subsequent chapter.

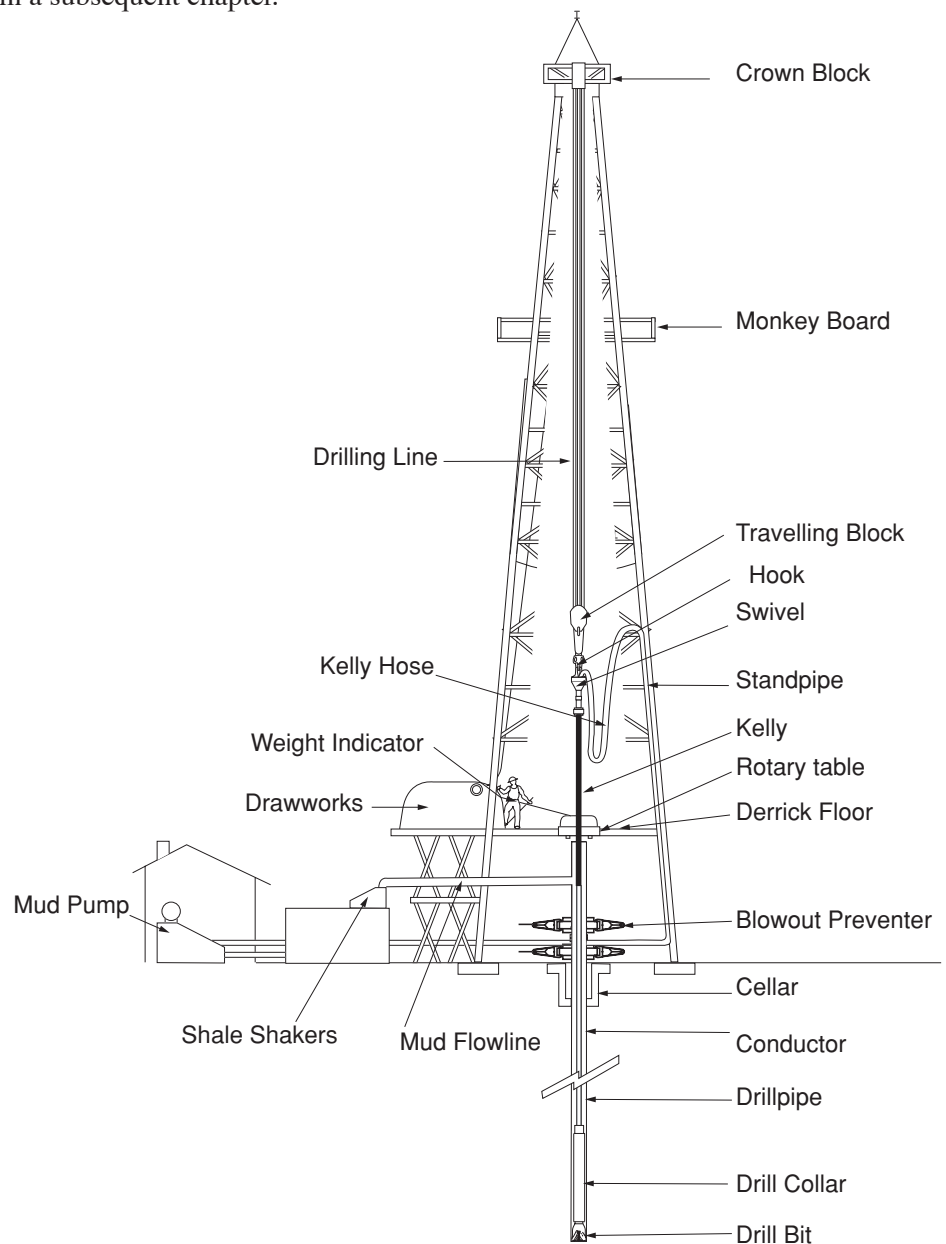

Figure 1 Rotary Drilling Rig

2. POWER SYSTEM

Most drilling rigs are required to operate in remote locations where a power supply is not available. They must therefore have a method of generating the electrical power which is used to operate the systems mentioned above. The electrical power generators are driven by diesel powered internal combustion engines (**prime movers**). Electricity is then supplied to electric motors connected to the **drawworks**, **rotary table** and **mud pumps** (Figure 2). The rig may have, depending on its size and capacity, up to 4 prime movers, delivering more than 3000 horsepower. Horsepower (hp) is an old, but still widely used, unit of power in the drilling industry.

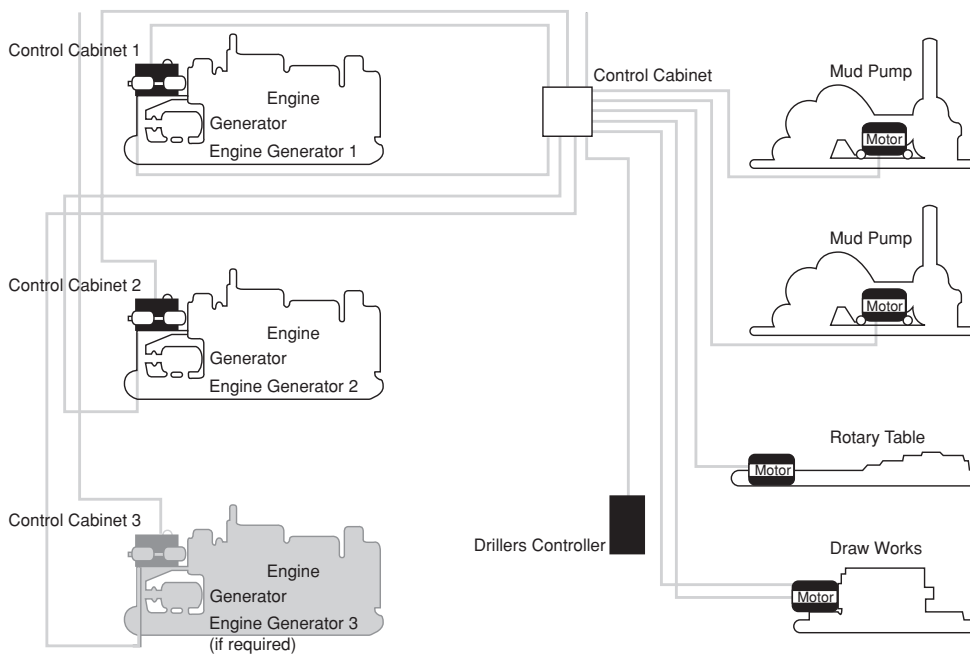

Figure 2 Power system

Older rigs used steam power and mechanical transmission systems but modern drilling rigs use electric transmission since it enables the driller to apply power more smoothly, thereby avoiding shock and vibration. The drawworks and the mud pumps are the major users of power on the rig, although they are not generally working at the same time.

3. HOISTING SYSTEM

The hoisting system is a large pulley system which is used to lower and raise equipment into and out of the well. In particular, the hoisting system is used to raise and lower the drillstring and casing into and out of the well. The components parts of the hoisting system are shown in Figure 3. The **drawworks** consists of a large revolving drum, around which a wire rope (**drilling line**) is spooled. The drum of the drawworks is connected to an electric motor and gearing system. The driller controls the drawworks with a clutch and gearing system when lifting equipment out of the well and a brake (friction and electric) when running equipment into the

well. The drilling line is threaded (**reeved**) over a set of **sheaves** in the top of the derrick, known as the **crown block** and down to another set of sheaves known as the **travelling block**. A large hook with a snap-shut locking device is suspended from the travelling block. This **hook** is used to suspend the drillstring. A set of clamps, known as the **elevators**, used when running, or pulling, the drillstring or casing into or out of the hole, are also connected to the travelling block.

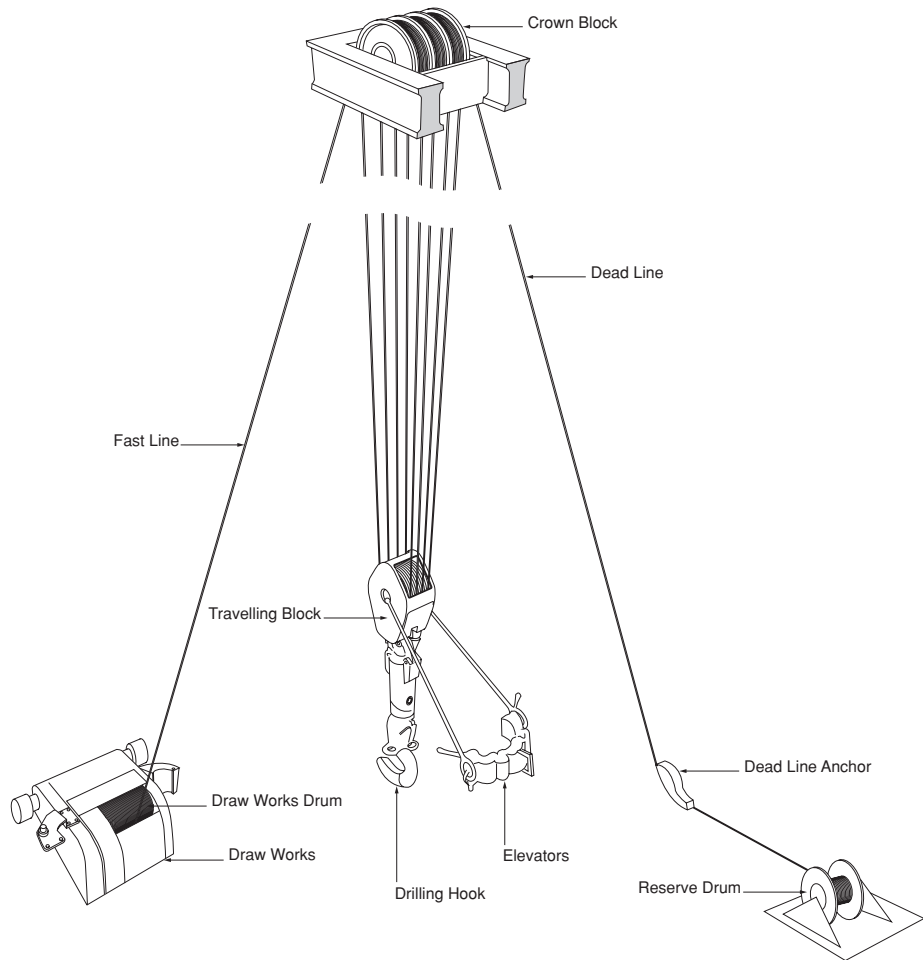

Figure 3 Hoisting system

Having reeved the drilling line around the crown block and travelling block, one end of the drilling line is secured to an anchor point somewhere below the rig floor. Since this line does not move it is called the **deadline**. The other end of the drilling line is wound onto the drawworks and is called the **fastline**. The drilling line is usually reeved around the blocks several times. The tensile strength of the drilling line and the number of times it is reeved through the blocks will depend on the load which must be supported by the hoisting system. It can be seen from Figure 3 that the tensile load (lbs.) on the drilling line, and therefore on the fast line, F_f and dead line F_d in a frictionless system can be determined from the total load supported by the drilling lines, W (lbs.) and the number of lines, N reeved around the crown and travelling block:

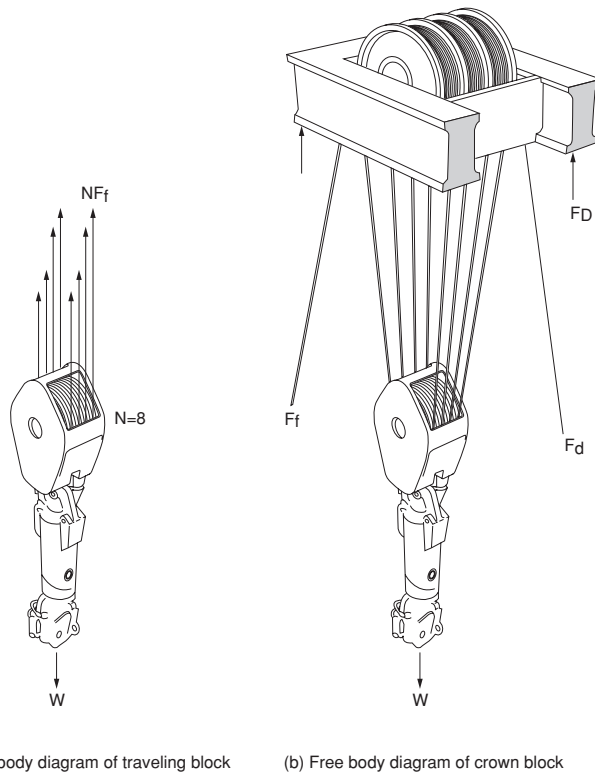

Figure 4 Drilling line tension

$$F_f = F_d = W/N$$

There is however inefficiency in any pulley system. The level of inefficiency is a function of the number of lines. An example of the efficiency factors for a particular system is shown in Table 1. These efficiency factors are quoted in API RP 9B - Recommended Practice on Application, Care and Use of Wire Rope for Oilfield Services. The tensile load on the drilling line and therefore on the fast line will then be :

$$F_f = W/EN$$

where E is the Efficiency of the from Table 1. The load on the deadline will not be a function of the inefficiency because it is static.

Number of Lines (N)	Efficiency (E)
6	0.874
8	0.842
10	0.811
12	0.782
14	0.755

Table 1 Efficiency Factors for Wire Rope Reaving, for Multiple Sheave Blocks (API RP 9B)

Note: Table 1 applies to Four Sheave Roller Bearing System with One idler Sheave.

The power output by the drawworks, HP_d will be proportional to the drawworks load, which is equal to the load on the fast line F_f , times the velocity of the fast line v_f (ft/min.)

$$HP_d = \frac{F_f v_f}{33,000}$$

Eight lines are shown in Figure 3 but 6, 8, 10, or 12 lines can be reeved through the system, depending on the magnitude of the load to be supported and the tensile rating of the drilling line used. The tensile capacity of some common drilling line sizes are given in Table 2. If the load to be supported by the hoisting system is to be increased then either the number of lines reeved, or a drilling line with a greater tensile strength can be used. The number of lines will however be limited by the capacity of the crown and travelling block sheaves being used.

The drilling line does not wear uniformly over its entire length whilst drilling. The most severe wear occurs when picking up the drillstring, at the point at which the rope passes over the top of the crown block sheaves. The line is maintained in good condition by regularly conducting a **slip** or a **slip and cut operation**. In the case of the slipping operation the travelling block is lowered to the drillfloor, the dead line anchor is unclamped and some of the reserve line is threaded through the sheaves on the travelling block and crown block onto the drawworks drum. This can only be performed two or three times before the drawworks drum is full and a slip and cut operation must be performed. In this case the travelling block is lowered to the drillfloor, the dead line anchor is unclamped and the line on the drawworks is unwound and discarded before the reserve line is threaded through the system onto the drawworks drum.

The decision to slip or slip and cut the drilling line is based on an assessment of the work done by the line. The amount of work done by the drilling line when tripping, drilling and running casing is assessed and compared to the allowable work done, as shown in Table 2. The work done is expressed in Ton-miles and is calculated as follows:

Nominal Breaking strength of 6 x 19 I.W.R.C (Independant Wire Rope Core) Blockline (lbs)			
Nominal Diameter	Ton-miles between cuts	Improved Plowed Steel	Extra Improved Plowed Steel
1"	8	89,800	103,400
1 1/8"	12	113,000	130,000
1 1/4"	16	138,800	159,800
1 3/8"	20	167,000	192,000
1 1/2"	24	197,800	228,000

Table 2 Allowable work and Nominal Breaking Strength of Drilling Line



Round Trip Operations:

The greatest amount of work is done by the drilling line when running and pulling the drillstring from the well. The amount of work done per round trip (running the string in hole and pulling it out again) can be calculated from the following:

$$T_r = \frac{D(L_s + D)W_m}{10,560,000} + \frac{D(M + 0.5C)}{2,640,000}$$

All of the terms used in these equations are defined below.

Drilling Ahead:

The amount of work done whilst drilling ahead is expressed in terms of the work performed in making trips. Analysis of the cycle of operations performed during drilling shows that the work done during drilling operations can be expressed as follows:

$$T_d = 3(T_2 - T_1)$$

If reaming operations and pulling back the kelly to add a single or double are ignored then the work becomes:

$$T_d = 2(T_2 - T_1)$$

Running Casing:

The amount of work done whilst running casing is similar to that for round tripping pipe but since the casing is only run in hole it is one half of the work. The amount of work done can be expressed as:

$$T_c = \frac{D(L_c + D)W_c + 4DM}{21,120,000}$$

Short Trips:

The amount of work done in pulling the drillstring back to the previous casing shoe and running back to bottom, for example to ream the hole can be expressed as in terms of the round trips calculated above:

$$T_{ST} = 2(T_4 - T_3)$$

where:

- T_r = Ton-miles for Round Trips
- T_{ST} = Ton-miles for Short Trips
- T_d = Ton-miles whilst drilling
- T_c = Ton-miles for Casing Operations
- D = Depth of hole (ft)
- L_s = Length of drillpipe stand (ft)
- L_c = Length of casing joint (ft)

- W_m = wt/ft of drillpipe in mud (lb/ft)
- W_c = wt/ft of casing in mud (lb/ft)
- M = wt. of blocks and elevators (lb)
- C = wt. of collars - wt. of drillpipe
(for same length in mud)
- T_1 = Ton miles for 1 round trip at start depth (D1)
- T_2 = Ton miles for 1 round trip at final depth (D2)
- T_3 = Ton miles for 1 round trip at depth D3
- T_4 = Ton miles for 1 round trip at depth D4

The selection of a suitable rig generally involves matching the derrick strength and the capacity of the hoisting gear. Consideration must also be given to mobility and climatic conditions. The standard derrick measures 140' high, 30' square base, and is capable of supporting 1,000,000 lbs weight. (Figure 5).

The maximum load which the derrick must be able to support can be calculated from the loads shown in Figure 4. The total load will be equal to:

$$F_D = W + F_f + F_d$$

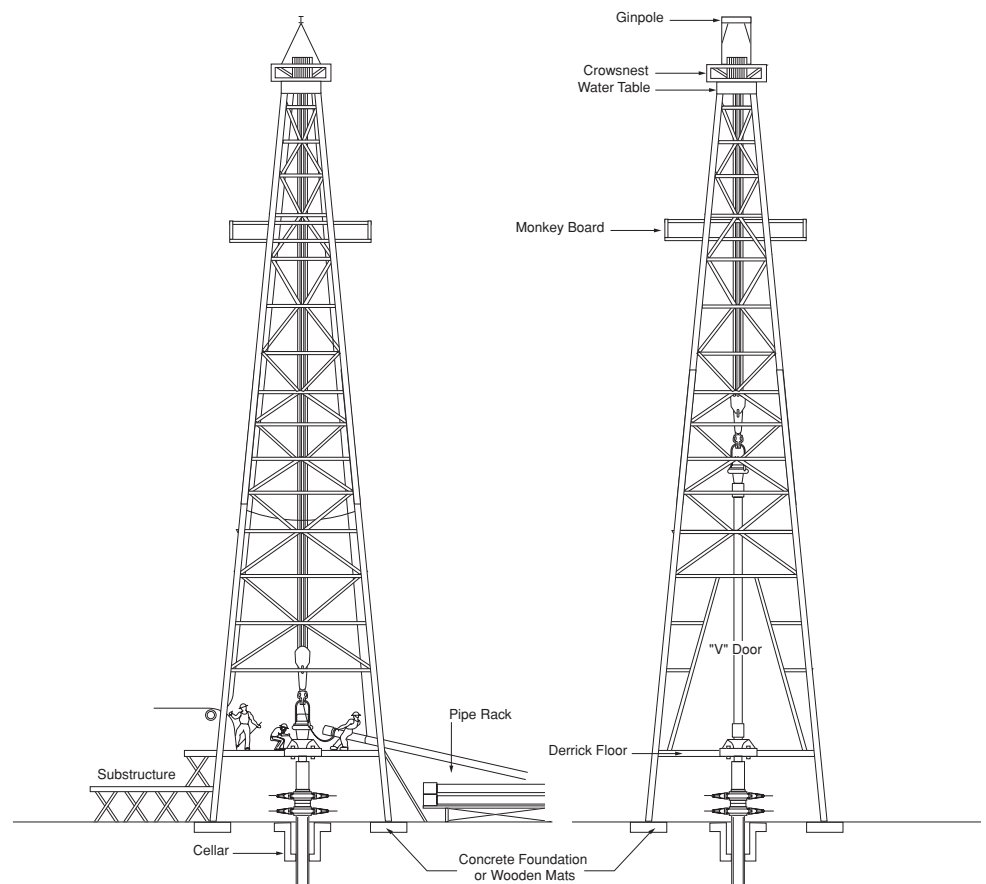

Figure 5 Drilling derrick

Exercise 1 The Hoisting System

A drillstring with a buoyant weight of 200,000 lbs must be pulled from the well. A total of 8 lines are strung between the crown block and the travelling block. Assuming that a four sheave, roller bearing system is being used.

- a. Compute the tension in the fast line
 - b. Compute the tension in the deadline
 - c. Compute the vertical load on the rig when pulling the string
-
-

4. Circulating System

The circulating system is used to circulate drilling fluid down through the drillstring and up the annulus, carrying the drilled cuttings from the face of the bit to surface. The main components of the circulating system are shown in Figure 6. The main functions of the drilling fluid will be discussed in a subsequent chapter - Drilling Fluids. However, the two main functions of the drilling fluid are:

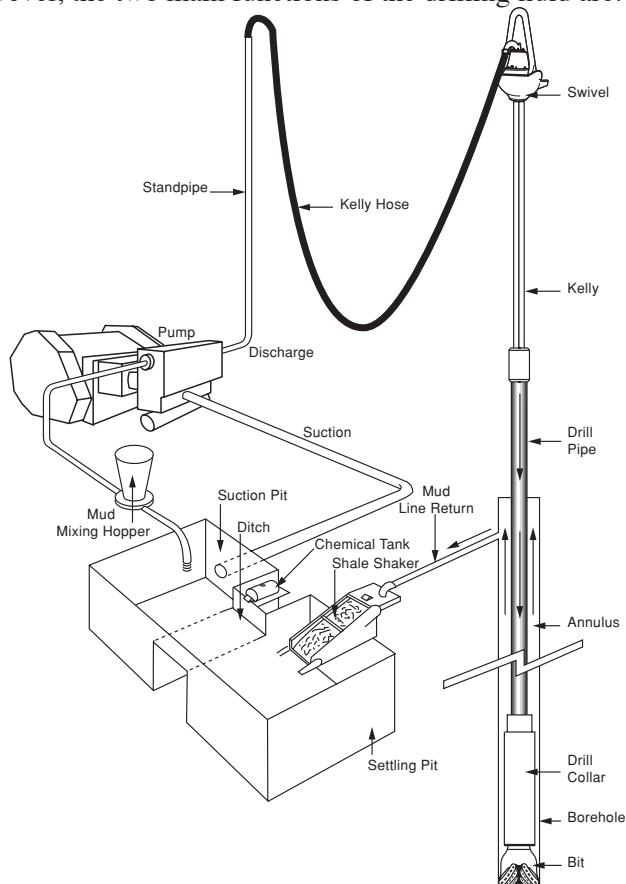

Figure 6 Circulating system

- To clean the hole of cuttings made by the bit
- To exert a hydrostatic pressure sufficient to prevent formation fluids entering the borehole

Drilling fluid (**mud**) is usually a mixture of water, clay, weighting material (**Barite**) and chemicals. The mud is mixed and conditioned in the mud pits and then circulated downhole by large pumps (**slush pumps**). The mud is pumped through the standpipe, kelly hose, swivel, kelly and down the drillstring. At the bottom of the hole the mud passes through the bit and then up the annulus, carrying cuttings up to surface. On surface the mud is directed from the annulus, through the **flowline** (or mud return line) and before it re-enters the mudpits the drilled cuttings are removed from the drilling mud by the **solids removal equipment**. Once the drilled cuttings have been removed from the mud it is re-circulated down the hole. The mud is therefore in a continuous circulating system. The properties of the mud are checked continuously to ensure that the desired properties of the mud are maintained. If the properties of the mud change then chemicals will be added to the mud to bring the properties back to those that are required to fulfil the functions of the fluid. These chemicals will be added whilst circulating through the mud pits or mud with the required properties will be mixed in separate mud pits and slowly mixed in with the circulating mud.

When the mud pumps are switched off, the mud will stop flowing through the system and the level of the mud inside the drillstring will equal the level in the annulus. The level in the annulus will be equal to the height of the mud return flowline. If the mud continues to flow from the annulus when the mud pumps are switched off then an influx from the formation is occurring and the well should be closed in with the Blowout preventer stack (See below). If the level of fluid in the well falls below the flowline when the mud pumps are shut down **losses** are occurring (the mud is flowing into the formations downhole). Losses will be discussed at length in a subsequent chapter.

The **mud pits** are usually a series of large steel tanks, all interconnected and fitted with agitators to maintain the solids, used to maintain the density of the drilling fluid, in suspension. Some pits are used for circulating (e.g. suction pit) and others for mixing and storing fresh mud. Most modern rigs have equipment for storing and mixing bulk additives (e.g. barite) as well as chemicals (both granular and liquid). The mixing pumps are generally high volume, low pressure **centrifugal pumps**.

At least 2 slush pumps are installed on the rig. At shallow depths they are usually connected in parallel to deliver high flow rates. As the well goes deeper the pumps may act in series to provide high pressure and lower flowrates.

Positive displacement type pumps are used (reciprocating pistons) to deliver the high volumes and high pressures required to circulate mud through the drillstring and up the annulus. There are two types of positive displacement pumps in common use:

- (i) Duplex (2 cylinders) - double acting
- (ii) Triplex (3 cylinders) - single acting

Triplex pumps are generally used in offshore rigs and **duplex pumps** on land rigs. Duplex pumps (Figure 7) have two cylinders and are double-acting (i.e. pump on the up-stroke and the down-stroke). Triplex pumps (Figure 8) have three cylinders and are single-acting (i.e. pump on the up-stroke only). Triplex pumps have the advantages of being lighter, give smoother discharge and have lower maintenance costs.

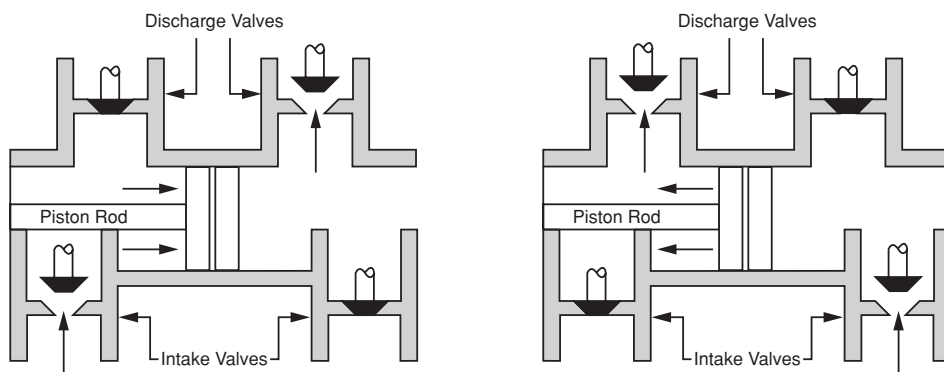

Figure 7 Duplex pump

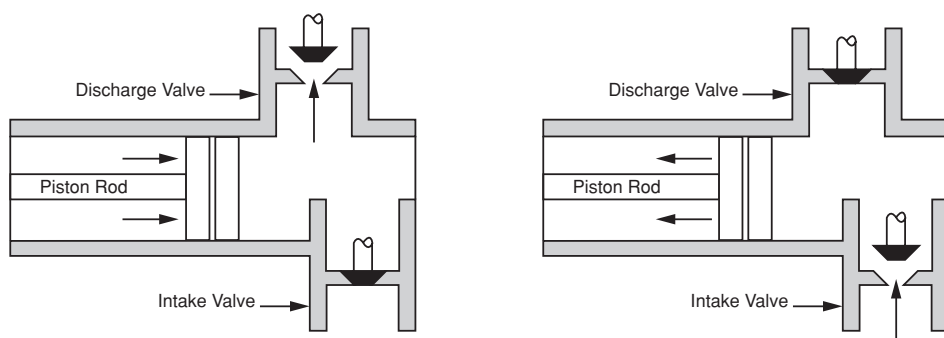

Figure 8 Triplex pump

The discharge line from the mud pumps is connected to the **standpipe** - a steel pipe mounted vertically on one leg of the derrick. A flexible rubber hose (**kelly hose**) connects the top of the standpipe to the **swivel** via the **gooseneck**. The swivel will be discussed in the section on rotary system below.

Once the mud has been circulated round the system it will contain suspended drilled cuttings, perhaps some gas and other contaminants. These must be removed before the mud is recycled. The mud passes over a **shale shaker**, which is basically a vibrating screen. This will remove the larger particles, while allowing the residue (**underflow**) to pass into settling tanks. The finer material can be removed using other solids removal equipment. If the mud contains gas from the formation it will be passed through a **degasser** which separates the gas from the liquid mud. Having passed through all the mud processing equipment the mud is returned to the mud tanks for recycling.

There will be at least two pumps on the rig and these will be connected by a mud manifold. When drilling large diameter hole near surface both pumps are connected in parallel to produce high flow rates. When drilling smaller size hole only one pump is usually necessary and the other is used as a back-up. The advantages of using reciprocating positive displacement pumps are that they can be used to:

- Pump fluids containing high solids content
- Operate over a wide range of pressures and flow rates

and that they are:

- Reliable
- Simple to operate, and easy to maintain

The flowrate and pressure delivered by the pump depends on the size of sleeve (**liner**) that is placed in the cylinders of the pumps. A liner is basically a replaceable tube which is placed inside the cylinder to decrease the bore.

The Power output of a mud pump is measured in Hydraulic Horsepower. The horsepower delivered by a pump can be calculated from the following:

$$\text{HHP} = \frac{P \times Q}{1714}$$

where,

HHP = Horsepower

Q = Flow rate (gpm)

P = Pressure (psi)

Since the power rating of a pump is limited (generally to about 1600 hp) and that the power consumption is a product of the output pressure and flowrate, the use of a smaller liner will increase the discharge pressure but reduce the flow rate and vice versa. It can be seen from the above equation that when operating at the maximum pump rating, an increase in the pump pressure will require a decrease in the flowrate and vice versa. The pump pressure will generally be limited by the pressure rating of the flowlines on the rig and the flowrate will be limited by the size of the liners in the pump and the rate at which the pump operates.



The mechanical efficiency (E_m) of a pump is related to the operation of the prime movers and transmission system. For most cases E_m is taken as 0.9. Volumetric efficiency (E_v) depends on the type of pump being used, and is usually between 0.9 and 1.0. The overall efficiency is the product of E_m and E_v .

Duplex Pumps

A schematic diagram of a duplex pump is shown in Figure 7. As the piston moves forward discharging fluid ahead of it, the inlet port allows fluid to enter the chamber behind it. On the return the fluid behind the piston is discharged (i.e. on the rod side) while fluid on the other side is allowed in. The theoretical displacement on the forward stroke is:

$$V_1 = \frac{\pi d^2 L}{4}$$

where,

d = liner diameter

L = stroke length

on the return stroke

$$V_2 = \frac{\pi(d^2 - d_r^2)L}{4}$$

where,

d_r = rod diameter

Taking account of the 2 cylinders, and the volumetric efficiency E_v the total displacement (in gallons) of one pump revolution is:

$$2(V_1 + V_2)E_v = \frac{2\pi(2d^2 - d_r^2)LE_v}{4}$$

The pump output can be obtained by multiplying this by the pump speed in revolutions per minute. (In oilfield terms 1 complete pump revolution = 1 stroke, therefore pump speed is usually given in strokes per minute) e.g. a duplex pump operating at a speed of 20 spm means 80 cylinder volumes per minute. Pump output is given by:

$$Q = \frac{(2d^2 - d_r^2)LE_v R}{147}$$

where,

Q = flow rate (gpm)

d = liner diameter (in.)

d_r = rod diameter (in.)
 L = stroke length (in.)
 R = pump speed (spm)

These flow rates are readily available in manufacturers' pump tables.

Triplex Pumps

A schematic diagram for a triplex pump is given in Figure 8. The piston discharges in only one direction, and so the rod diameter does not affect the pump output. The discharge volume for one pump revolution is:

$$= 3V_1E_v = \frac{3\pi d^2LE_v}{4}$$

Again the pump output is found by multiplying by the pump speed:

$$Q = \frac{d^2LE_vR}{98.03}$$

where,

Q = flow rate (gpm)
 L = stroke length (in.)
 d = liner diameter (in.)
 R = pump speed (spm)

More power can be delivered using a triplex pump since higher pump speeds can be used. They will also produce a smoother discharge since they pump an equal volume at every 120 degree rotation of the crankshaft. (A pulsation dampener, or desurger, can be installed on both duplex and triplex pumps to reduce the variation in discharge pressure). The efficiency of a triplex pump can be increased by using a small centrifugal pump to provide fluid to the suction line. Triplex pumps are generally lighter and more compact than duplex pumps of similar capacity, and so are most suitable for use on offshore rigs and platforms.

Exercise 2 The Mud Pumps

Calculate the following, for a triplex pump having 6in. liners and 11in. stroke operating at 120 spm and a discharge pressure of 3000 psi.

- a. The volumetric output at 100% efficiency
 - b. The Horsepower output of the pump when operating under the conditions above.
-



5. ROTARY SYSTEM

The rotary system is used to rotate the drillstring, and therefore the drillbit, on the bottom of the borehole. The rotary system includes all the equipment used to achieve bit rotation (Figure 9).

The *swivel* is positioned at the top of the drillstring. It has 3 functions:

- Supports the weight of the drill string
- Permits the string to rotate
- Allows mud to be pumped while the string is rotating

The hook of the travelling block is latched into the bail of the swivel and the kelly hose is attached to the gooseneck of the swivel.

The **kelly** is the first section of pipe below the swivel. It is normally about 40' long, and has an outer hexagonal cross-section. It must have this hexagonal (or sometimes square) shape to transmit rotation from the rotary table to the drillstring. The kelly has a right hand thread connection on its lower [pin] end, and a left hand thread connection on its upper [box] end. A short, inexpensive piece of pipe called a **kelly saver sub** is used between the kelly and the first joint of drillpipe. The kelly saver sub prevents excessive wear of the threads of the connection on the kelly, due to continuous make-up and breakout of the kelly whilst drilling. **Kelly cocks** are valves installed at either end of the kelly to isolate high pressures and prevent backflow from the well if an influx occurs at the bottom of the well. The **rotary table** is located on the drill floor and can be turned in both clockwise and anti-clockwise directions. It is controlled from the drillers console. This rotating table has a square recess and four post holes. A large cylindrical sleeve, called a **master bushing**, is used to protect the rotary table.

The torque from the rotary table is transmitted to the kelly through the four pins on a device which runs along the length of the kelly, known as the **kelly bushing**. The kelly bushing has 4 pins, which fit into the post holes of the rotary table. When power is supplied to the rotary table torque is transmitted from the rotating table to the kelly via the kelly bushing. The power requirements of the rotary table can be determined from:

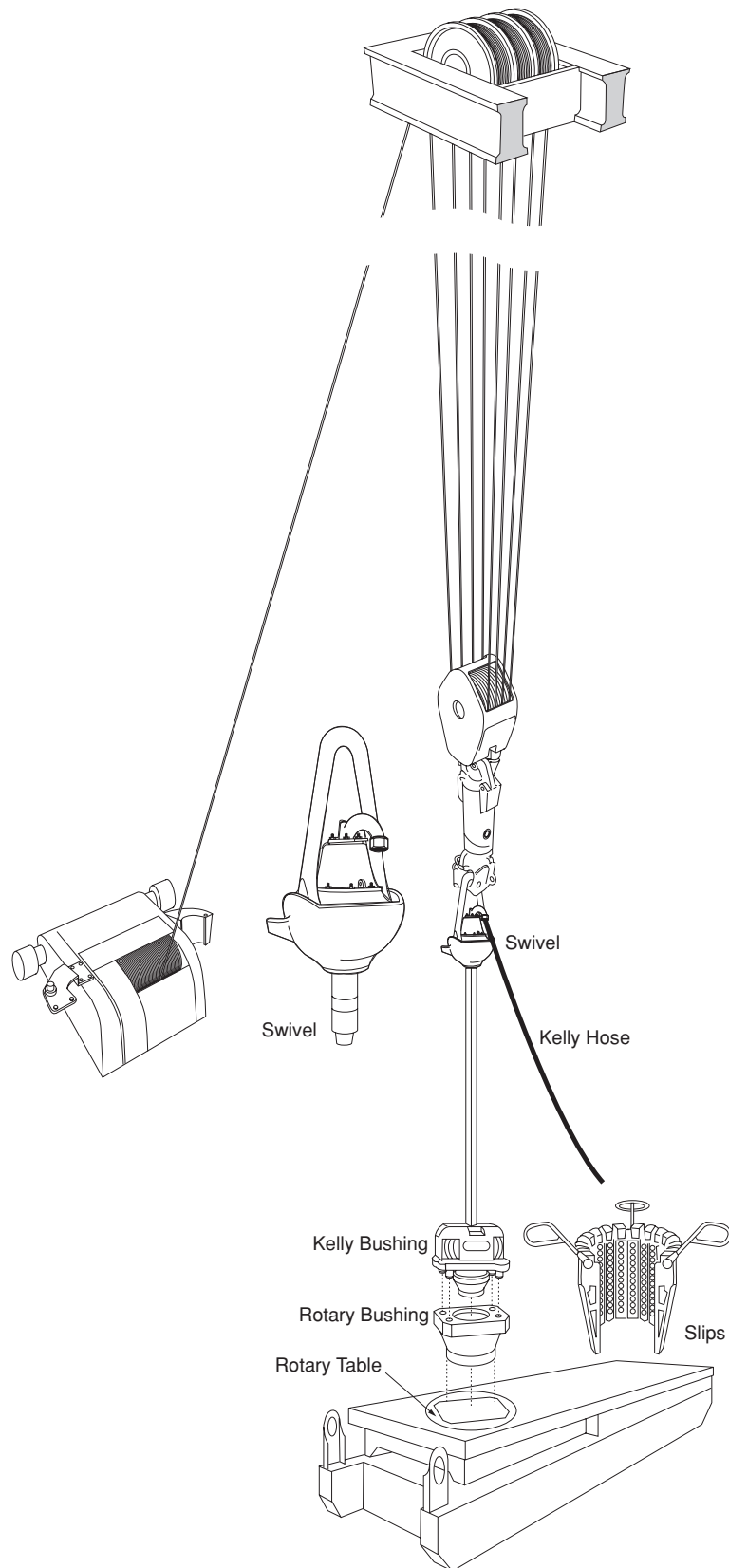

Figure 9 Rotary system

$$P_{rt} = \frac{\omega T}{2\pi}$$

where,

P_{rt} = Power (hp)

ω = Rotary Speed (rpm)

T = Torque (ft-lbf)

Slips are used to suspend pipe in the rotary table when making or breaking a connection. Slips are made up of three tapered, hinged segments, which are wrapped around the top of the drillpipe so that it can be suspended from the rotary table when the top connection of the drillpipe is being screwed or unscrewed. The inside of the slips have a serrated surface, which grips the pipe (Figure 9).

To unscrew (or “**break**”) a connection, two large wrenches (or **tongs**) are used. A **stand** (3 lengths of drillpipe) of pipe is raised up into the derrick until the lowermost drillpipe appears above the rotary table. The roughnecks drop the slips into the gap between the drillpipe and master bushing in the rotary table to wedge and support the rest of the drillstring. The **breakout tongs** are latched onto the pipe above the connection and the **make up tongs** below the connection (Figure 10). With the make-up tong held in position, the driller operates the breakout tong and breaks out the connection.

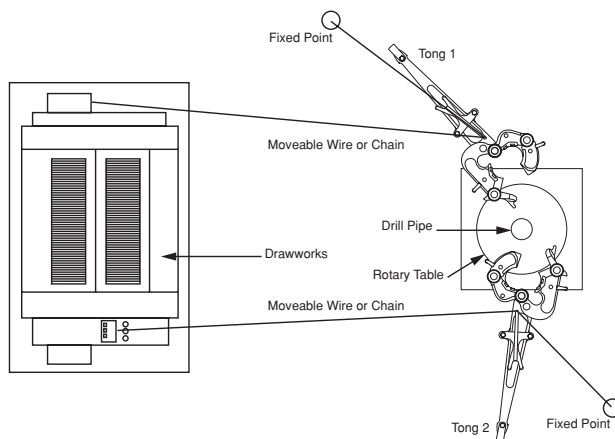

Figure 10 Tubing makeup and breakout

To make a connection the make-up tong is put above, and the breakout tong below the connection. This time the breakout tong is fixed, and the driller pulls on the make-up tong until the connection is tight. Although the tongs are used to break or tighten up a connection to the required torque, other means of screwing the connection together, prior to torquing up, are available:

- For making up the kelly, the lower tool joint is fixed by a tong while the kelly is rotated by a **kelly spinner**. The kelly spinner is a machine which is operated by compressed air.

- A **drillpipe spinner** (power tongs) may be used to make up or backoff a connection (powered by compressed air).
- For making up some subs or special tools (e.g. MWD subs) a **chain tong** is often used.

5.1 Procedure for Adding Drillpipe when Drilling Ahead:

When drilling ahead the top of the kelly will eventually reach the rotary table (this is known as *kelly down*). At this point a new joint of pipe must be added to the string in order to drill deeper. The sequence of events when adding a joint of pipe is as follows (Figure 11):

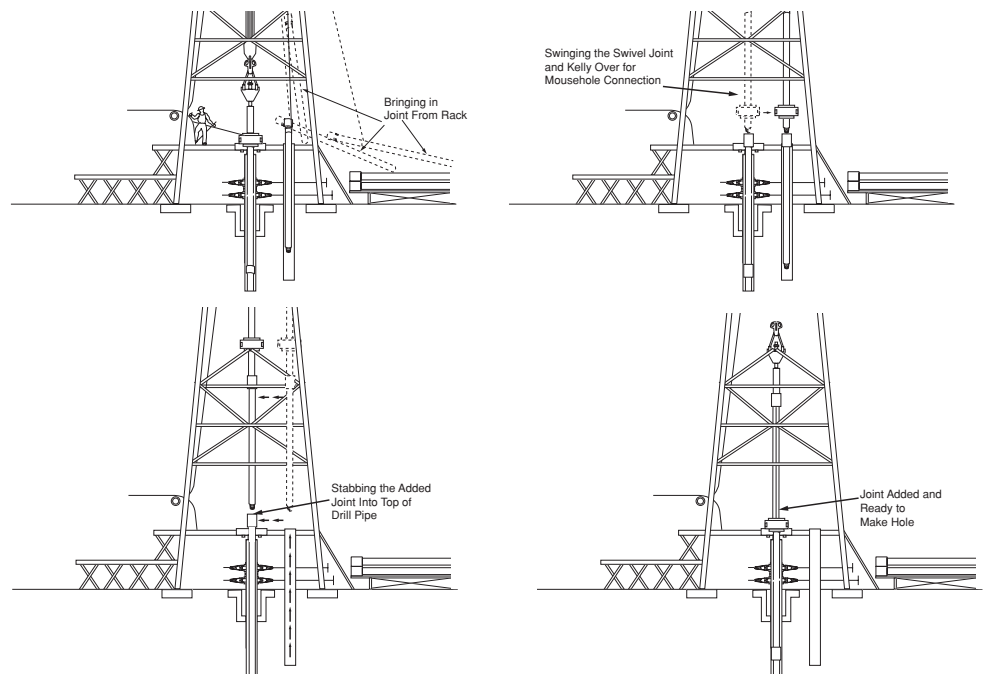

Figure 11 Procedure for adding drill pipe to the drillstring

1. Stop the rotary table, pick up the kelly until the connection at the bottom of the kelly saver sub is above the rotary table, and stop pumping.
2. Set the drillpipe slips in the rotary table to support the weight of the drillstring, break the connection between the kelly saver sub and first joint of pipe, and unscrew the kelly.
3. Swing the kelly over to the next joint of drillpipe which is stored in the **mousehole** (an opening through the floor near the rotary table).
4. Stab the kelly into the new joint, screw it together and use tongs to tighten the connection.

5. Pick up the kelly and new joint out of the mousehole and swing the assembly back to the rotary table.
6. Stab the new joint into the connection above the rotary table and make-up the connection.
7. Pick up the kelly, pull the slips and run in hole until the kelly bushing engages the rotary table.
8. Start pumping, run the bit to bottom and rotate and drill ahead.

This procedure must be repeated every 30ft as drilling proceeds.

5.2 Procedure for Pulling the Drillstring from the Hole:

When the time comes to pull out of the hole the following procedure is used (Figure 12):

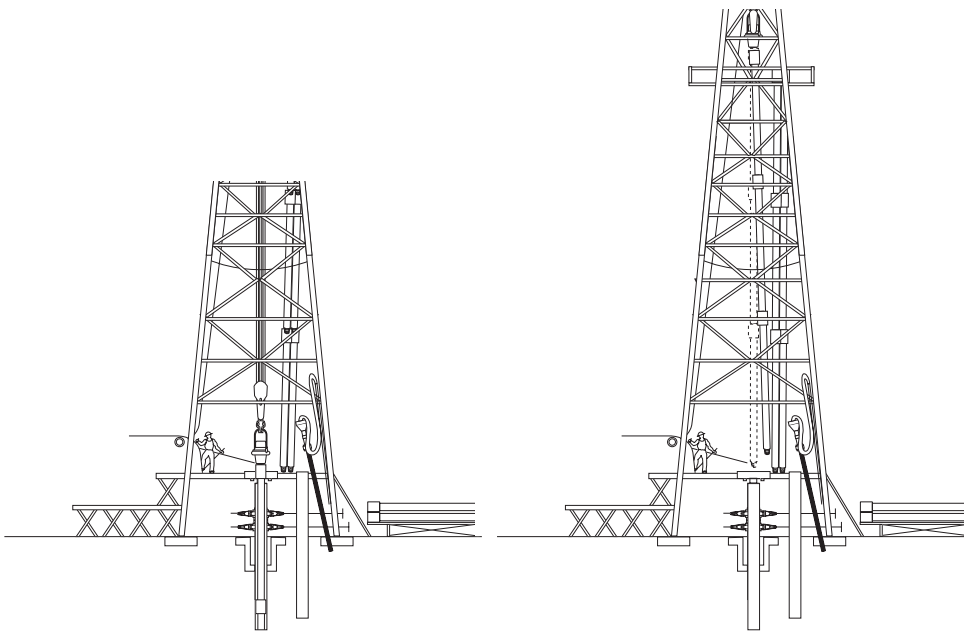

Figure 12 Procedure for pulling pipe from the hole

1. Stop the rotary, pick up the kelly until the connection at the bottom of the kelly saver sub is above the rotary table, and stop pumping
2. Set the drillpipe slips, break out the kelly and set the kelly back in the **rat-hole** (another hole in the rig floor which stores the kelly and swivel when not in use)
3. Remove the swivel from the hook (i.e. kelly, kelly bushing, swivel and kelly hose all stored in rathole)

4. Latch the elevators onto the top connection of the drillpipe, pick up the drillpipe and remove the slips. Pull the top of the drillpipe until the top of the drillpipe is at the top of the derrick and the second connection below the top of the drillpipe is exposed at the rotary table. A **stand** (3 joints of pipe) is now exposed above the rotary table
5. Roughnecks use tongs to break out the connection at the rotary table and carefully swings the bottom of the stand over to one side. Stands must be stacked in an orderly fashion.
6. The Derrickman, on the **monkey board**, grabs the top of the stand, and sets it back in fingerboard.

When running pipe into the hole it is basically the same procedure in reverse.

5.3 Iron Roughneck

On some rigs a mechanical device known as an **iron roughneck** may be used to make-up and break-out connections. This machine runs on rails attached to the rig floor, and is easily set aside when not in use. Its mobility allows it to carry out mousehole connections when the tracks are correctly positioned. The device consists of a spinning wrench and torque wrench, which are both hydraulically operated. Advantages offered by this device include controlled torque, minimal damage to threads (thereby increasing the service life of the drillpipe) and reducing crew fatigue.

5.4 Top Drive Systems

Most offshore drilling rigs now have **top drive systems** installed in the derrick. A top drive system consists of a power swivel, driven by a 1000 hp dc electric motor. This power swivel is connected to the travelling block and both components run along a vertical guide track which extends from below the crown block to within 3 metres of the rig floor. The electric motor delivers over 25000 ft-lbs torque and can operate at 300 rpm. The power swivel is remotely controlled from the driller's console, and can be set back if necessary to allow conventional operations to be carried out.

A pipe handling unit, which consists of a 500 ton elevator system and a torque wrench, is suspended below the power swivel. These are used to break out connections. A hydraulically actuated valve below the power swivel is used as a kelly cock.

A top drive system replaces the functions of the rotary table and allows the drillstring to be rotated from the top, using the power swivel instead of a kelly and rotary table (Figure 13). The power swivel replaces the conventional rotary system, although a conventional rotary table would generally, also be available as a back up.

The advantages of this system are:

- It enables complete 90' stands of pipe to be added to the string rather than the conventional 30' singles. This saves rig time since 2 out of every 3 connections are eliminated. It also makes coring operations more efficient

- When tripping out of the hole the power swivel can be easily stabbed into the string to allow circulation and string rotation when pulling out of hole, if necessary (e.g. to prevent stuck pipe)
- When tripping into the hole the power swivel can be connected to allow any bridges to be drilled out without having to pick up the kelly

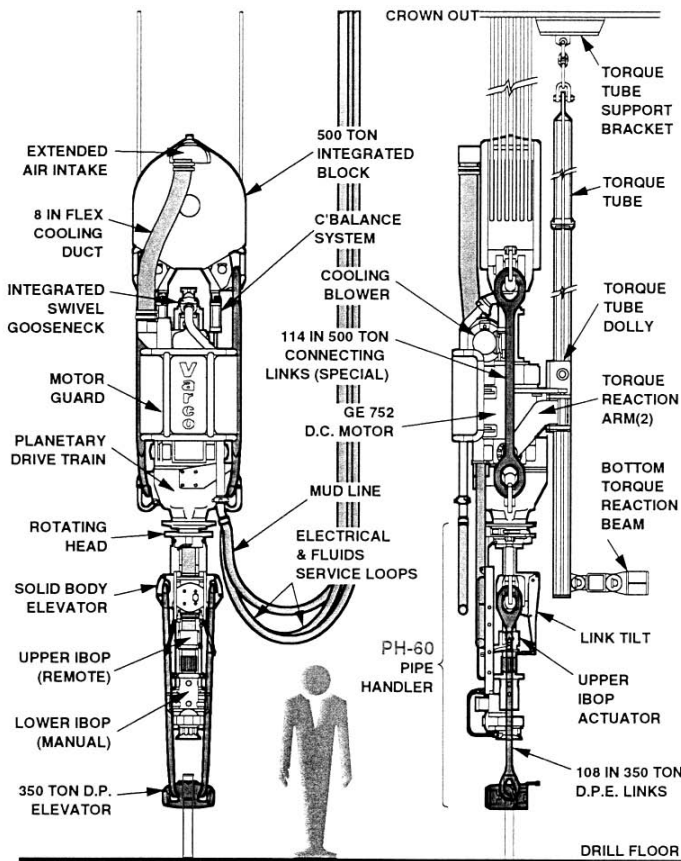

IDS-1 General Arrangement & Components

Figure 13 Top drive system (Courtesy of Varco)

The procedures for adding a stand, when using a top drive system is as follows:

1. Suspend the drillstring from slips, as in the conventional system, and stop circulation
2. Break out the connection at the bottom of the power sub
3. Unlatch the elevators and raise the block to the top of the derrick
4. Catch the next stand in the elevators, and stab the power sub into the top of the stand

5. Make up the top and bottom connections of the stand
6. Pick up the string, pull slips, start pumps and drill ahead

Top drive systems are now very widely used. The disadvantages of a top drive system are:

- Increase in topside weight on the rig
- Electric and hydraulic control lines must be run up inside the derrick
- When drilling from a semi-submersible under heaving conditions the drillstring may bottom out during connections when the string is hung off in the slips. This could be overcome by drilling with doubles and a drilling sub which could be broken out like a Kelly. This method however would reduce the time-saving advantages of the top drive system

6. WELL CONTROL SYSTEM

The function of the well control system is to prevent the uncontrolled flow of formation fluids from the wellbore. When the drillbit enters a permeable formation the pressure in the pore space of the formation may be greater than the hydrostatic pressure exerted by the mud column. If this is so, formation fluids will enter the wellbore and start displacing mud from the hole. Any influx of formation fluids (oil, gas or water) in the borehole is known as a ***kick***.

The well control system is designed to:

- Detect a kick
- Close-in the well at surface
- Remove the formation fluid which has flowed into the well
- Make the well safe

Failure to do this results in the uncontrolled flow of fluids - known as a ***blow-out*** - which may cause loss of lives and equipment, damage to the environment and the loss of oil or gas reserves. **Primary well control** is achieved by ensuring that the hydrostatic mud pressure is sufficient to overcome formation pressure. Hydrostatic pressure is calculated from:

$$P = 0.052 \times MW \times TVD$$

where:

P = hydrostatic pressure (psi)

MW = mud weight (ppg)

TVD = vertical height of mud column (ft)

Primary control will only be maintained by ensuring that the mud weight is kept at the prescribed value, and keeping the hole filled with mud. **Secondary well control** is achieved by using valves to prevent the flow of fluid from the well until such time as the well can be made safe.

6.1 Detecting a kick

There are many signs that a driller will become aware of when a kick has taken place. The first sign that a kick has taken place could be a sudden increase in the level of mud in the pits. Another sign may be mud flowing out of the well even when the pumps are shut down (i.e. without circulating). Mechanical devices such as pit level indicators or mud flowmeters which trigger off alarms to alert the rig crew that an influx has taken place are placed on all rigs. Regular pit drills are carried out to ensure that the driller and the rig crew can react quickly in the event of a kick.

6.2 Closing in the Well

Blow out preventors (BOPs) must be installed to cope with any kicks that may occur. BOPs are basically high pressure valves which seal off the top of the well. On land rigs or fixed platforms the BOP stack is located directly beneath the rig floor. On floating rigs the BOP stack is installed on the sea bed. In either case the valves are hydraulically operated from the rig floor.

There are two basic types of BOP.

Annular preventor - designed to seal off the annulus between the drillstring and the side of hole (may also seal off open hole if kick occurs while the pipe is out of the hole). These are made of synthetic rubber which, when expanded, will seal off the cavity (Figure 14).

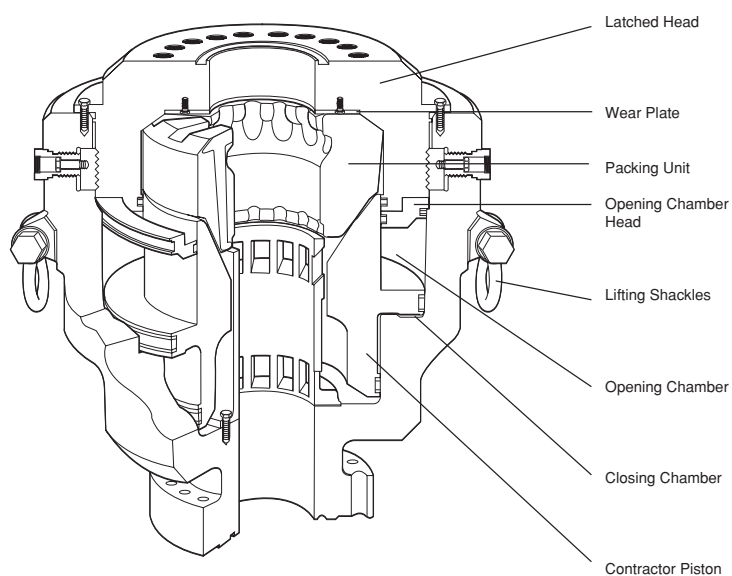

Figure 14 Hydril annular BOP (Courtesy of Hydril*)

Ram type preventor - designed to seal off the annulus by ramming large rubber-faced blocks of steel together. Different types are available:

- blind rams - seal off in open hole
- pipe rams - seal off around drillpipe (Figure 15)
- shear rams - sever drillpipe (used as last resort)

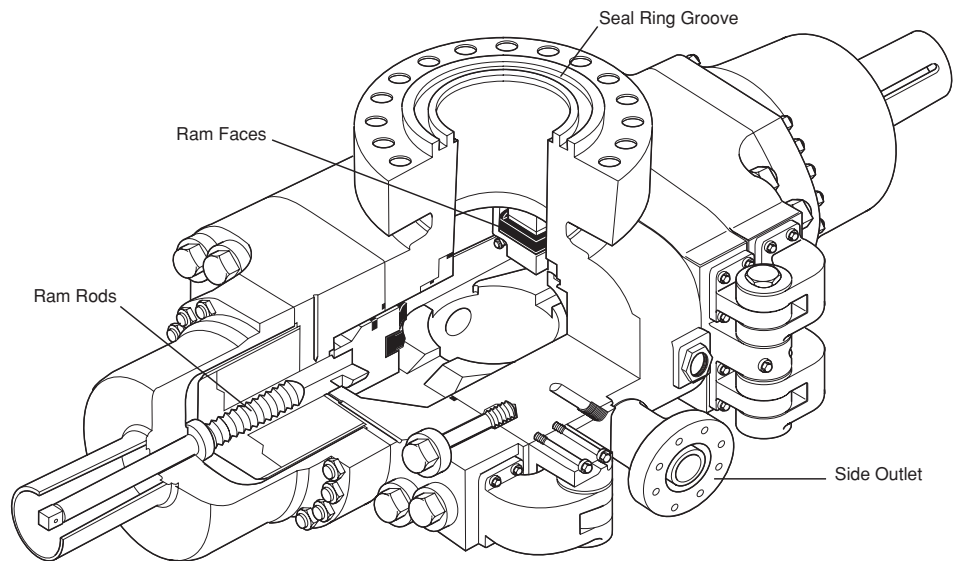

Figure 15 Ram type BOP (Courtesy of Hydril*)

Normally the BOP stack will contain both annular and ram type preventors (Figure 16).

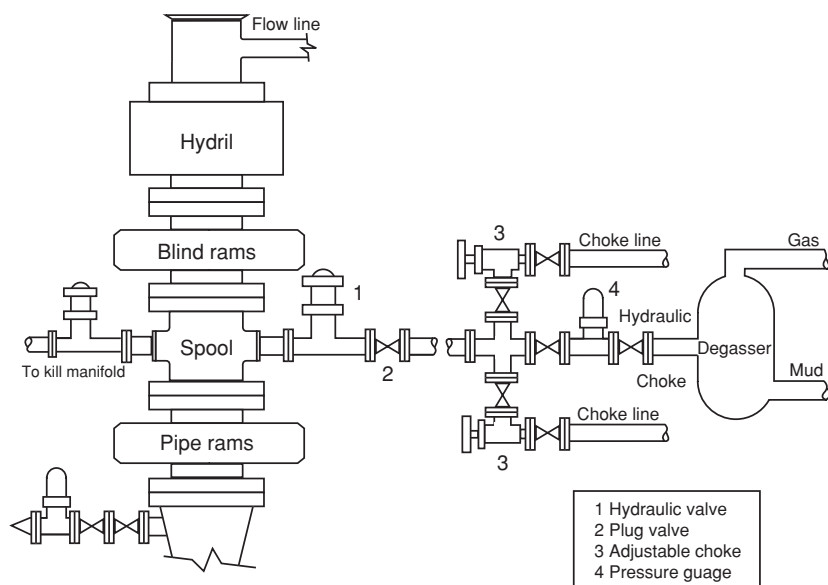

Figure 16 BOP stackup



To stop the flow of fluids from the drillpipe, the kelly cock valves can be closed, or an **internal BOP** (basically a non-return check valve preventing upward flow) can be fitted into the drillstring.

6.3 Circulating out a kick

To remove the formation fluids now trapped in the annulus a high pressure circulating system is used. A **choke manifold** with an adjustable choke is used to control flow rates during the circulation. Basically heavier mud must be pumped down the drillpipe to control the formation pressure, and the fluids in the annulus circulated to surface. As the kick starts moving up the hole the choke opening is restricted to hold enough back pressure on the formation to prevent any further influx. The fluids are circulated out via the choke line, through the choke manifold out to a gas/mud separator and a flare stack (Figure 16). Once the heavier mud has reached surface the well should be **dead**. Well control procedures will be dealt with more fully later.

7. WELL MONITORING SYSTEM

Safety requires constant monitoring of the drilling process. If drilling problems are detected early remedial action can be taken quickly, thereby avoiding major problems. The driller must be aware of how drilling parameters are changing (e.g. WOB, RPM, pump rate, pump pressure, gas content of mud etc.). For this reason there are various gauges installed on the driller's console where he can read them easily.

Another useful aid in monitoring the well is **mudlogging**. The mudlogger carefully inspects rock cuttings taken from the shale shaker at regular intervals. By calculating lag times the cuttings descriptions can be matched with the depth and hence a log of the formations being drilled can be drawn up. This log is useful to the geologist in correlating this well with others in the vicinity. Mudloggers also monitor the gas present in the mud by using gas chromatography.

Solutions to Exercises

Exercise 1 The Hoisting System

A drillstring with a buoyant weight of 200,000 lbs must be pulled from the well. A total of 8 lines are strung between the crown block and the travelling block. Assuming that a four sheave, roller bearing system is being used.

- a. The tension in the fast line :

$$T_F = \frac{200,000}{8 \times 0.842}$$

$$T_F = 29691 \text{ lbs}$$

- b. The tension in the deadline

$$T_D = \frac{200,000}{8}$$

$$T_D = 25000 \text{ lbs}$$

- c. The vertical load on the rig when pulling the string

$$\begin{aligned} \text{Total} &= 200000 + 29691 + 25000 \\ &= 254691 \text{ lbs} \end{aligned}$$

Exercise 2 The Mud Pumps

Consider a triplex pump having 6in. liners and 11in. stroke operating at 120 spm and a discharge pressure of 3000 psi.

- a. The volumetric output at 100% efficiency

$$\begin{aligned} Q &= \frac{6^2 \times 11 \times 1.0 \times 120}{98.03} \\ &= 485 \text{ gpm} \end{aligned}$$

- b. The Horsepower output of the pump when operating under the conditions above.

$$\begin{aligned} \text{HP} &= \frac{3000 \times 485}{1714} \\ &= 849 \text{ hp} \end{aligned}$$

The Drillstring 3

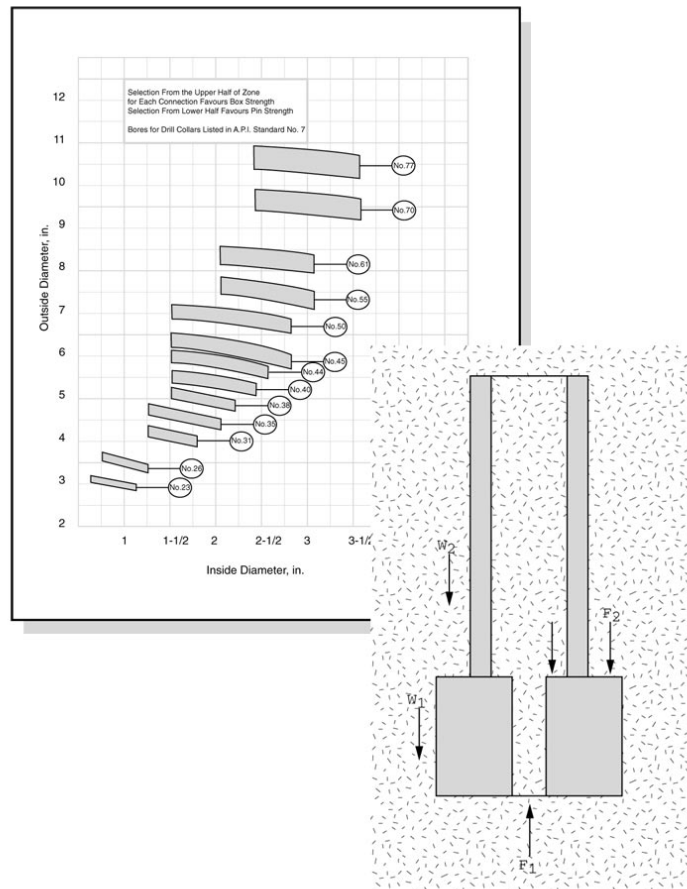

CONTENTS

1. INTRODUCTION
2. DRILLPIPE
 - 2.1 Drillpipe Stress and Failure
 - 2.2 Drillpipe Inspection
3. TOOL JOINTS
4. HEAVY WALL DRILLPIPE (HWDP)
5. DRILL COLLARS
 - 5.1 Special Types of Collar
6. OTHER DRILLSTRING COMPONENTS
 - 6.1 Stabilisers
 - 6.2 Roller Reamer
 - 6.3 Shock sub (vibration dampener)
 - 6.4 Subs (substitutes)
 - 6.5 Drilling Jars
7. DRILL STRING DESIGN
 - 7.1 Design of a Stabilised String
 - 7.2 Bending Moments in String Design
 - 7.3 Length of Drillcollars
 - 7.4 Drill Pipe Selection
 - 7.4 Design Procedure





LEARNING OBJECTIVES

Having worked through this chapter the student will be able to:

General:

- Describe the basic components and the function of each component in the drillstring.

Drillpipe:

- Describe the components parts of a joint of drillpipe.
- Describe the way in which drillpipe is classified in terms of size, weight and grade
- Describe the stresses and wear mechanisms to which the drillstring is exposed.
- Describe the techniques used to inspect drillpipe and the worn pipe classification system.

Tooljoints:

- Describe a tooljoint and identify the major characteristics of a tooljoint

HWDP:

- Describe HWDP
- Describe the reasons for running HWDP.

Drillcollars:

- Describe the reasons for using Drillcollars.
- Describe the loads to which Drillcollars are subjected.
- Describe the function of: conventional; Spiral; Square and Monel Drillcollars.

BHA Components:

- Describe the function of: Stabilisers; Roller Reamers; Shock Subs; Subs; and Drilling Jars.
- Describe the ways in which the above are configured in the BHA.

Drillstring Design:

- Calculate the dry weight and buoyant weight of the drillstring.
- Calculate the length of drillcollar required for a drilling operation.
- Calculate the Section Modulus of component parts of the drillstring.

1. INTRODUCTION

The term **drillstring** is used to describe the tubulars and accessories on which the drillbit is run to the bottom of the borehole. The drillstring consists of **drillpipe**, **drillcollars**, the kelly and various other pieces of equipment such as stabilisers and reamers, which are included in the drillstring just above the drillbit (Figure 1). All of these components will be described in detail below. The drillcollars and the other equipment which is made up just above the bit are collectively called the **Bottom Hole Assembly (BHA)**. The dimensions of a typical 10,000 ft drillstring would be :

Component	Outside Diameter (in.)	Length (ft)
Drillbit	12 1/4"	
Drillcollars	9 1/2"	600
Drillpipe	5"	9400

The functions of the drillstring are:

- To suspend the bit
- To transmit rotary torque from the kelly to the bit
- To provide a conduit for circulating drilling fluid to the bit

It must be remembered that in deep wells the drillstring may be 5-6 miles long.

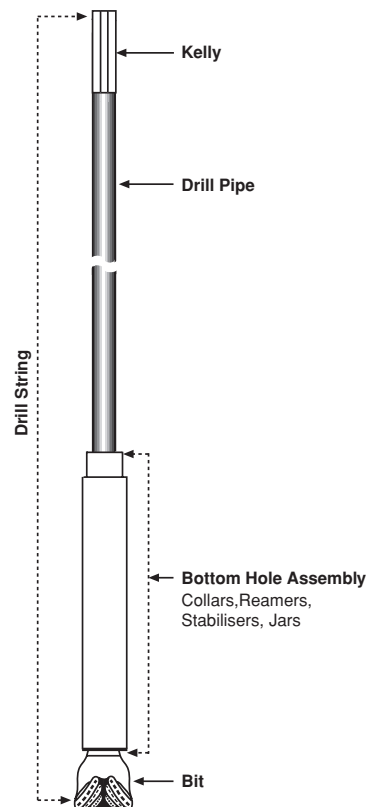

Figure 1 Components of the drillstring

2. DRILL PIPE

Drillpipe is the major component of the drillstring. It generally constitutes 90-95% of the entire length of the drillstring. Drillpipe is a seamless pipe with threaded connections, known as **tooljoints** (Figure 2). At one end of the pipe there is the **box**, which has the female end of the connection. At the other end of each length of drillpipe is the male end of the connection known as the **pin**. The wall thickness and therefore the outer diameter of the tooljoint must be larger than the wall thickness of the main body of the drillpipe in order to accommodate the threads of the connection. Hence the tooljoints are clearly visible in the drillstring. Tooljoints will be discussed in greater depth below.

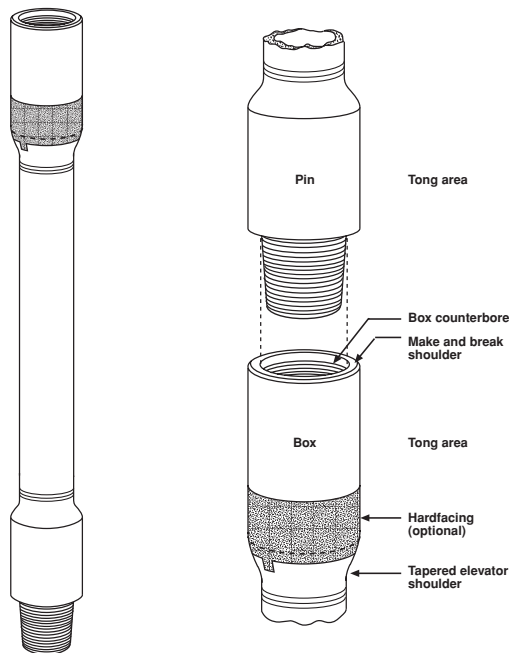

Figure 2 Tooljoint

Each length of drillpipe is known as a **joint** or a **single**. The standard dimensions for drillpipe are specified by the American Petroleum Institute. Singles are available in three API length “ranges” (see Table 1) with range 2 being the most common. The exact length of each single must be measured on the rigsite since the process used to manufacture the drillpipe means that singles are not of uniform length. Since the only way in which the driller knows the depth of the drillbit is by knowing the length of the drillstring the length of each length of drillpipe (and all other drillstring components) made up into the drillstring must be measured and recorded on a drillpipe **tally**. The drillpipe is also manufactured in a variety of outside diameters, and weights (Table 2) which assuming a specific gravity for steel of 490 lb/cuft, is a reflection of the wall thickness of the drillpipe. The drillpipe is also manufactured in a variety of material grades (Table 3). The specification for a particular string of drillpipe could therefore appear as:

5” 19.5 lb/ft Grade S Range 2

API Range	Length (ft)
1	18-22
2	27-30
3	38-45

Table 1 Drillpipe Lengths

Size(OD) (inches)	Weight (lb/ft)	ID (inches)
2 ³ / ₈	6.65	1.815
2 ⁷ / ₈	10.40	2.151
3 ¹ / ₂	9.50	2.992
3 ¹ / ₂	13.30	2.764
5	15.50	4.602
5	16.25	4.408
5	19.50	4.276
5 ¹ / ₂	25.60	4.000
5 ¹ / ₂	21.90	4.776
5 ¹ / ₂	24.70	4.670

Table 2 Dimensions of Drillpipe

API Grade	Minimum Yield Stress (psi)	Minimum Tensile Stress (psi)	<u>Yield Stress</u> / <u>Tensile Stress</u> ratio
D	55,000	95,000	0.58
E	75,000	100,000	0.75
X	95,000	105,000	0.70
G	105,000	115,000	0.91
S	135,000	145,000	0.93

Table 3 Drillpipe Material Grades

All of these specifications will influence the burst, collapse, tensile and torsional strength of the drillpipe and this allows the drilling engineer to select the pipe which will meet the specific requirements of the particular drilling operation.

Care must be taken when using the specifications given in Table 2 since although these are the normally quoted specifications for drillpipe, the weights and dimensions are 'nominal' values and do not reflect the true weight of the drillpipe or the minimum internal diameter of the pipe.



The weight per foot of the pipe is a function of the connection type and grade of the drillpipe and the weight per foot that should be used when calculating the true weight of a string of pipe is given in Table 13.

The weight of the pipe calculated in the manner described above will reflect the weight of the drillpipe when suspended in air (“**Weight in air**”). When the pipe is suspended in the borehole it will be immersed in drilling fluid of a particular density and will therefore be subjected to a buoyant force. This buoyant force will be directly proportional to the density of the drilling fluid. The weight of drillpipe when suspended in a fluid (“**Wet Weight**”) can be calculated from the following:

$$\begin{aligned} \text{Buoyant Weight (“Wet Weight”) of Drillpipe} \\ = \text{Weight of pipe in Air} \times \text{Buoyancy Factor} \end{aligned}$$

The buoyancy factor for a particular density of drilling fluid can be found from Table 15.

Exercise 1 Dimensions and weight of drillpipe

- a. What is the weight in air of a joint (30ft) of 5” 19.5 lb/ft Grade G drillpipe with 4 1/2” IF connections:?

- b. What is the wet weight of this joint of drillpipe when immersed in a drilling fluid with a density of 12 ppg ?

2.1 Drillpipe Stress and Failure

It is not uncommon for the drillpipe to undergo tensile failure (*twistoff*) whilst drilling. When this happens, drilling has to stop and the drillstring must be pulled from the borehole. The part of the string below the point of failure will of course be left in the borehole when the upper part of the string is retrieved. The retrieval of the lower part of the string is a very difficult and time consuming operation.

The failure of a drillstring can be due to excessively high stresses and/or corrosion. Drillpipe is exposed to the following stresses:

- Tension - the weight of the suspended drillstring exposes each joint of drillpipe to several thousand pounds of tensile load. Extra tension may be exerted due to *overpull* (drag caused by difficult hole conditions e.g. dog legs) when pulling out of hole.
- Torque - during drilling, rotation is transmitted down the string. Again, poor hole conditions can increase the amount of torque or twisting force on each joint.
- Cyclic Stress Fatigue - in deviated holes, the wall of the pipe is exposed to compressive and tensile forces at points of bending in the hole. As the string is rotated each joint sustains a cycle of compressive and tensile forces (Figure 3). This can result in fatigue in the wall of the pipe.

Stresses are also induced by vibration, abrasive friction and bouncing the bit off bottom.

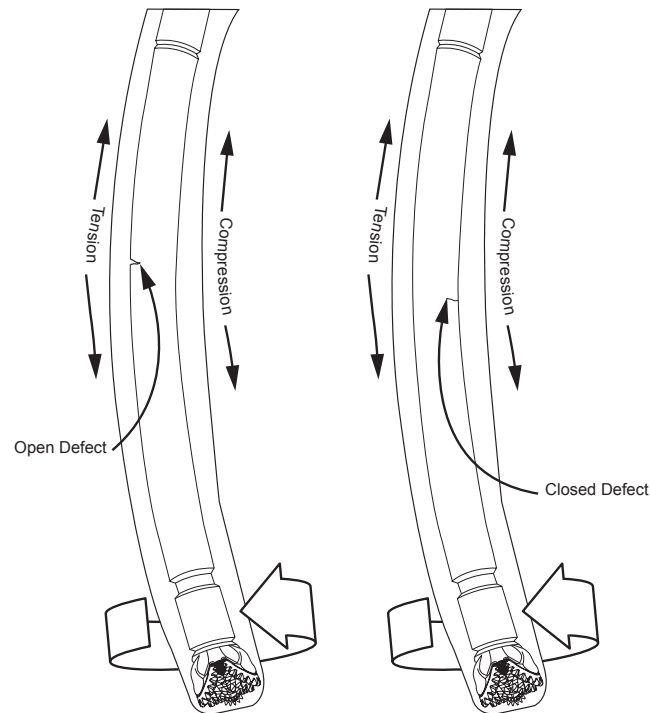

Figure 3 Cyclic loading

Corrosion of a drillstring in a water based mud is primarily due to dissolved gases, dissolved salts and acids in the wellbore, such as:

- Oxygen - present in all drilling fluids. It causes rusting and pitting. This may lead to washouts (small eroded hole in the pipe) and **twist offs** (parting of the drillstring). Oxygen can be removed from drilling fluids using a scavenger, such as sodium sulphate. Even small concentrations of oxygen (< 1 ppm) can be very damaging.
- Carbon dioxide - can be introduced into the wellbore with the drilling fluid (makeup water, organic drilling fluid additives or bacterial action on additives in the drilling fluid) or from the formation. It forms carbonic acid which corrodes steel.
- Dissolved Salts - increase the rates of corrosion due to the increased conductivity due to the presence of dissolved salts. Dissolved salts in drilling fluids may come from the makeup water, formation fluid inflow, drilled formations, or drilling fluid additives.
- Hydrogen sulphide - may be present in the formations being drilled. It causes “hydrogen embrittlement” or “sulphide stress cracking”. Hydrogen is absorbed on to the surface of a steel in the presence of sulphide. If the local concentration of hydrogen is sufficient, cracks can be formed, leading rapidly to a brittle failure.



Hydrogen embrittlement in itself does not cause a failure, but will accelerate failure of the pipe if it is already under stress or notched. Only small amounts of H₂S need be present to induce fatigue (< 13 ppm). Special scavengers can be circulated in the mud to remove the H₂S (e.g. filming amines).

- Organic acids - These produce corrosion by lowering the pH, remove protective films and provide hydrogen to increase hydrogen embrittlement.

Although added chemicals can build up a layer of protection against corrosion, the fatigue stresses easily break this layer down, allowing corrosion to re-occur. It is this interaction of fatigue and corrosion which is difficult to combat.

2.2 Drillpipe Inspection

When manufactured, new pipe will be subjected by the manufacturer to a series of mechanical, tensile and hydrostatic pressure tests in accordance with API Specification 5A and 5AX. This will ensure that the pipe can withstand specified loads. A joint of drillpipe will however be used in a number of wells. When it has been used it will undergo some degree of wear and will not be able to withstand the same loads as when it is new.

It is extremely difficult to predict the service life of a drillstring since no two boreholes experience the same drilling conditions. However, as a rough guide, the length of hole drilled by a piece of drillpipe, when part of a drillstring will be :

soft drilling areas:	220000 - 250000 ft
hard or deviated drilling areas:	180000 - 210000 ft

This means that a piece of drillpipe may be used on up to 25 wells which are 10,000 ft deep

During the working life of the drillpipe it will therefore be necessary to determine the degree of damage or wear that the pipe has already been subjected to and therefore its capacity to withstand the loads to which it will be exposed in the future. Various non-destructive tests are periodically applied to used drillpipe, to assess the wear and therefore strength of the pipe, and to inspect for any defects, e.g. cracks. The strength of the pipe is gauged on the basis of the remaining wall thickness, or if worn eccentrically, the average minimum wall thickness of the pipe. The methods used to inspect drillpipe are summarised in Table 4.

Following inspection, the drillpipe is classified in terms of the degree of wear or damage which is measured on the pipe. The criteria used for classifying the drillpipe on the basis of the degree of wear or damage is shown in Table 6. The 'Grade 1 or Premium' drillpipe classification applies to new pipe, or used pipe with at least 80% of the original wall thickness still remaining. A classification of Grade 2 and above indicates that the pipe has sustained significant wear or damage and that its strength has been significantly reduced. The strength of some typical drillpipe sizes when new, and when worn, is shown in tables 11 and 12.

Drillpipe will generally be inspected and classified before a new drilling contract is started. The operating company would require that the drilling contractor provide proof of inspection and classification of the drillstring as part of the drilling contract. In general, only new or premium drillpipe would be acceptable for drilling in the North Sea.

METHOD	DESCRIPTION	COMMENTS
Optical	Visual inspection	Slow and can be in error if pipe internals not properly cleaned
Magnetic Particle	Magnetise pipe ends and observe attraction of ferrous particles to cracks detected by UV light	Simple and efficient. No information on wall thickness
Magnetic Induction	Detect disturbances in magnetic flux field by pits, notches and cracks	No information on wall thickness. Internal cracks have to be verified using magnetic particle technique
Ultra Sonic	Pulse echo technique	No information on cracks. Very effective on determination of wall thickness
Gamma Ray		

Table 4 Summary of inspection techniques

3. TOOL JOINTS

Tooljoints are located at each end of a length of drillpipe and provide the screw thread for connecting the joints of pipe together (Figure 4). Notice that the only seal in the connection is the shoulder/shoulder connection between the box and pin. Initially tool joints were screwed on to the end of drillpipe, and then reinforced by welding. A later development was to have **shrunk-on tool joints**. This process involved heating the tool joint, then screwing it on to the pipe. As the joint cooled it contracted and formed a very tight, close seal. One advantage of this method was that a worn joint could be heated, removed and replaced by a new joint. The modern method is to **flash-weld** the tooljoints onto the pipe. A hard material is often welded onto the surface of the tooljoint to protect it from abrasive wear as the drillstring is rotated in the borehole. This material can then be replaced at some stage if it becomes depleted due to excessive wear. When two joints of pipe are being connected the rig tongs must be engaged around the tool joints (and not around the main body of the drillpipe), whose greater wall thickness can sustain the torque required to make-up the connection. The strength of a tool joint depends on the cross sectional area of the box and pin. With continual use the threads of the pin and box become worn, and there is a decrease in the tensile strength. The size of the tooljoint depends on the size of the drillpipe but various sizes of tool joint are available. The tooljoints that are commonly used for 4 1/2" drillpipe are listed in

Table 5. It should be noted that the I.D. of the tooljoint is less than the I.D. of the main body of the pipe.

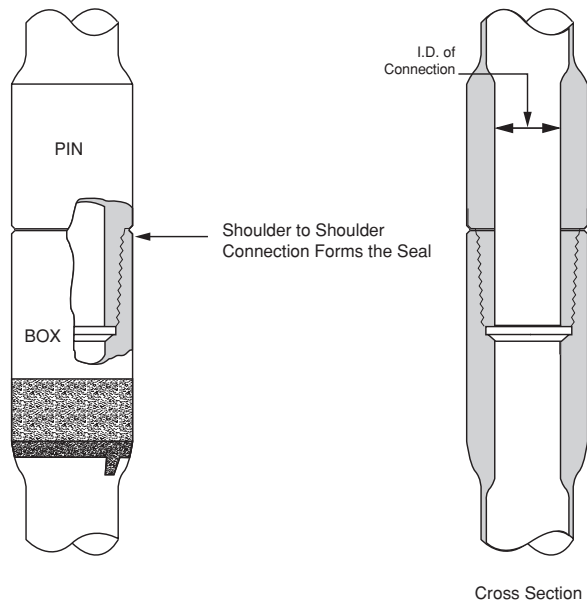

Figure 4 Tool joint

SIZE	TYPE	OD	ID	TPI	TAPE	THREAD FORM
4 1/2"	API REG	5 1/2"	2 1/4"	5	3	V..040
4 1/2"	Full Hole	5 3/4"	3"	5	3	V..040
4 1/2"	NC 46 (4" IF)	6"	3 1/4"	4	2	V..038R
4 1/2"	NC 50 (4 1/2" IF)	6 1/8"	3 3/4"	4	2	V..038R
4 1/2"	H.90	6"	3 1/4"	3 1/2"	2	90° V..050

Table 5 API tool joints

Tooljoint boxes usually have an 18 degree tapered shoulder, and pins have 35 degree tapered shoulders. Tool joints are subjected to the same stresses as drillpipe, but also have to face additional problems:

-
- When pipe is being tripped out the hole the elevator supports the string weight underneath the shoulder of the tool joint.
 - Frequent engagement of pins and boxes, if done harshly, can damage threads.
 - The threaded pin end of the pipe is often left exposed.

Tool joint life can be substantially extended if connections are greased properly when the connection is made-up and a steady torque applied.

4. HEAVY WALL DRILLPIPE (HWDP)

Heavy wall drillpipe (or heavy weight drillpipe) has a greater wall thickness than ordinary drillpipe and is often used at the base of the drillpipe where stress concentration is greatest. The stress concentration is due to:

- The difference in cross section and therefore stiffness between the drillpipe and drillcollars.
- The rotation and cutting action of the bit can frequently result in a vertical bouncing effect.

HWDP is used to absorb the stresses being transferred from the stiff drill collars to the relatively flexible drillpipe. The major benefits of HWDP are:

- Increased wall thickness
- Longer tool joints
- Uses more hard facing
- May have a long central upset section (Figure 5)

HWDP should always be operated in compression. More lengths of HWDP are required to maintain compression in highly deviated holes.



CLASSIFICATION OF USED DRILL PIPE AND USED TUBING WORK STRINGS
(All Sizes, Weights and Grades. Nominal dimension is basis for all calculations)

1	2	3	4
PIPE CONDITION	PREMIUM CLASS ¹ Two White Bands	CLASS 2 Yellow Band	CLASS 3 Orange Band
I. EXTERIOR CONDITIONS			
A. OD Wear Wall	Remaining wall not less than 80%	Remaining wall not less than 70%	Any imperfections or damages exceeding CLASS 2
B. Dents & Mashes	Not over 3% of OD	Not over 4% of OD	
C. Slip Area Diameter Variations			
1 Crushing ²	Not over 3% of OD	Not over 4% of OD	
2 Necking	Not over 3% of OD	Not over 4% of OD	
D. Stress Induced Diameter Variations			
1 Stretched	Not over 3% of OD reduction	Not over 4% of OD ³ reduction	
2 String Shot	Not over 3% of OD increase	Not over 4% of OD increase	
E. Cuts, Gouges & Corrosion			
1 Round Bottom	Remaining wall not less than 80%	Remaining wall not less than 70%	
2 Sharp Bottom			
Longitudinal	Remaining wall not less than 80%	Remaining wall not less than 70%	
Transverse ⁴	Remaining wall not less than 80% and length not over 10% of circumference	Remaining wall not less than 80% and length not over 10% of circumference	
F. Fatigue Cracks ⁴	None	None	None
II. INTERIOR CONDITIONS			
A. Corrosive Pitting Wall	Remaining wall not less than 80% measured from base of deepest pit	Remaining wall not less than 70% measured from base of deepest pit	
B. Erosion & Wear Wall	Remaining wall not less than 80%	Remaining wall not less than 70%	
C. Fatigue Cracks ⁴	None	None	None

Table 6 Classification of used drillpipe and used tubing work strings

5. DRILL COLLARS

Drillcollars are tubulars which have a much larger outer diameter and generally smaller inner diameter than drillpipe. A typical drillstring would consist of 9" O.D. x 2 13/16" I.D. drillcollars and 5" O.D. x 4.276" I.D. drillpipe. The drillcollars therefore have a significantly thicker wall than drillpipe. The function of drill collars are:

- To provide enough weight on bit for efficient drilling
- To keep the drillstring in tension, thereby reducing bending stresses and failures due to fatigue.
- To provide stiffness in the BHA for directional control.

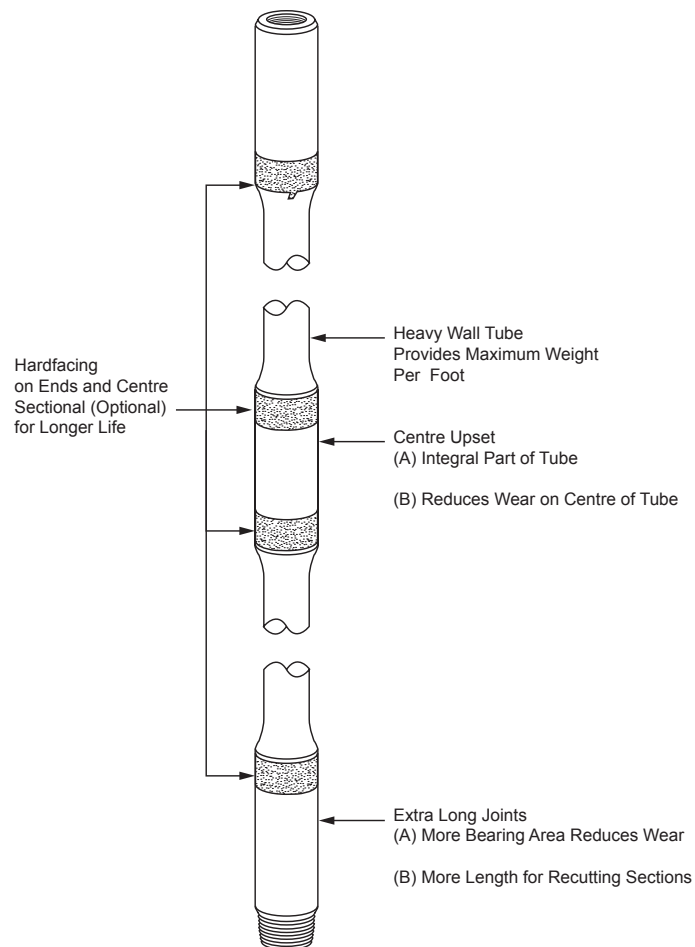

Figure 5 “Heavyweight” drillpipe

Since the drillcollars have such a large wall thickness tooljoints are not necessary and the connection threads can be machined directly onto the body of the collar. The weakest point in the drill collars is the connection and therefore the correct make up torque must be applied to prevent failure. The external surface of a regular collar is round (slick), although other profiles are available.

Drill collars are normally supplied in Range 2 lengths (30-32 ft). The collars are manufactured from chrome-molybdenum alloy, which is fully heat treated over the entire length. The bore of the collar is accurately machined to ensure a smooth, balanced rotation. Drill collars are produced in a large range of sizes with various types of joint connection. The sizes and weight per foot of a range of drillcollar sizes are shown in Table 14. The weights that are quoted in Table 14 are the “**weight in air**” of the drillcollars.

It is very important that proper care is taken when handling drill collars. The shoulders and threads must be lubricated with the correct lubricant (containing 40-60% powdered metallic-zinc or lead).

Like drillpipe, collars are subjected to stresses due to:

- Buckling and bending forces
- Tension
- Vibrations
- Alternate compression and tension.

However, if properly made up, the shoulder/shoulder connection will be sufficient to resist these stresses. Figure 6 shows how numbered connections should be selected to provide an efficient seal, and adequate strength.

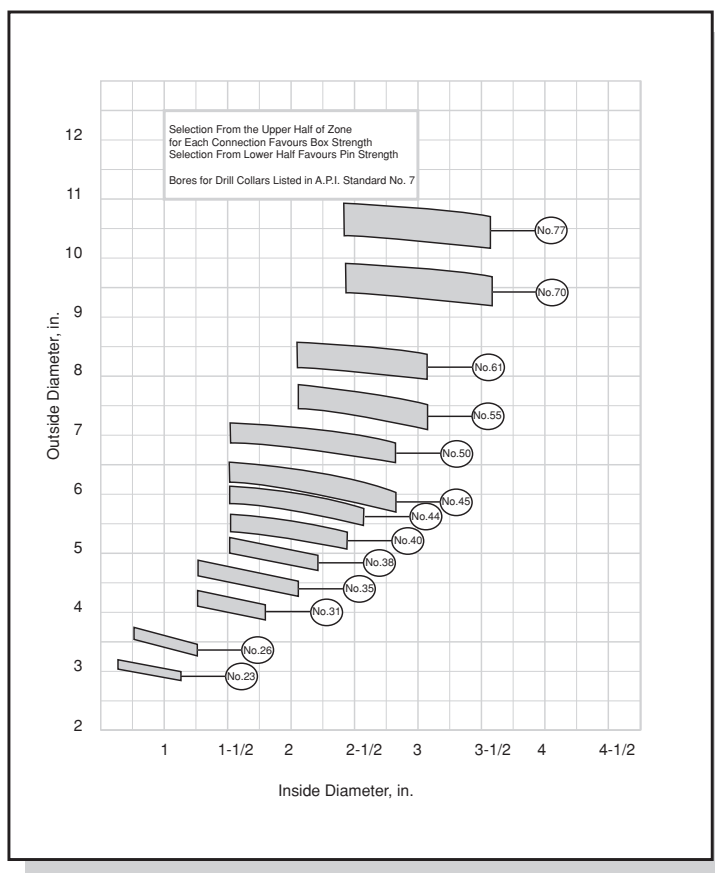

Figure 6 Numbered connections

Exercise 2 Drillcollar Dimensions and weights

- a. What is the weight in air of 200 ft of 9 1/2" x 2 13/16" drillcollar ?
 - b. What is the weight of this drillcollar when immersed in 13 ppg mud ?
 - c. It is not uncommon for 5" 19.5 lb/ft drillpipe to be used in the same string as 8 1/4" x 2 13/16" drillcollars (Table 10). Compare the nominal I.D. of this drillpipe and drillcollar size and note the differences in wall thickness of these tubulars.
-
-

5.1 Special Types of Collar

- Anti-wall stick

When drilling through certain formations the large diameter drillcollars can become stuck against the borehole (differential sticking). This is likely to happen when the formation is highly porous, a large overbalance of mud pressure is being used and the well is highly deviated. One method of preventing this problem is to reduce the contact area of the collar against the wellbore. Spiral grooves can be cut into the surface of the collar to reduce its surface area. (Figure 7)



Figure 7 Spiral drillcollar

- Square collars

These collars are usually 1/16" less than bit size, and are run to provide maximum stabilisation of the bottom hole assembly.

- Monel collars

These collars are made of a special non-magnetic steel alloy. Their purpose is to isolate directional survey instruments from magnetic distortion due to the steel drillstring.

6. OTHER DRILLSTRING COMPONENTS

6.1. Stabilisers

Stabilisers consist of a length of pipe with blades on the external surface. These blades may be either straight or spiral and there are numerous designs of stabilisers (Figure 8). The blades can either be fixed on to the body of the pipe, or mounted on a rubber sleeve (sleeve stabiliser), which allows the drillstring to rotate within it.

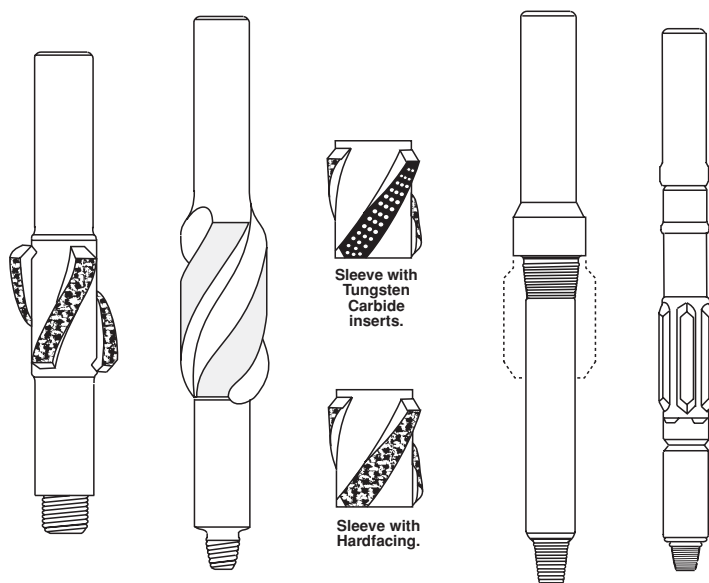

Figure 8 Stabilisers

The function of the stabiliser depends on the type of hole being drilled. In this section we are concerned only with drilling vertical holes. Drilling deviated holes will be dealt with later. In vertical holes the functions of stabilisers may be summarised as follows:

- Reduce buckling and bending stresses on drill collars
- Allow higher WOB since the string remains concentric even in compression.
- Increase bit life by reducing wobble (i.e. all three cones loaded equally).
- Help to prevent wall sticking.
- Act as a key seat wiper when placed at top of collars.

Generally, for a straight hole, the stabilisers are positioned as shown in Figure 9. Normally the stabilisers used will have 3 blades, each having a contact angle of 140 degrees (open design). When stabilisers begin to wear they become undergauge and are less efficient. Stabilisers are usually replaced if they become 1/2" undergauge (3/16" undergauge may be enough in some instances).

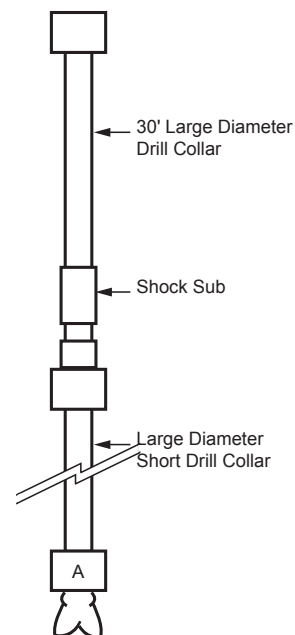

Figure 9 Stabiliser positions for straight hole drilling

6.2 Roller Reamer

A roller reamer consists of stabiliser blades with rollers embedded into surface of the blade. The rollers may be made from high grade carburised steel or have tungsten carbide inserts (Figure 10). The roller reamer acts as a stabiliser and is especially useful in maintaining gauge hole. It will also ream out any potential hole problems (e.g. dog legs, key seats, ledges).

6.3 Shock sub (vibration dampener)

A shock sub is normally located above the bit to reduce the stress due to bouncing when the bit is drilling through hard rock. The shock sub absorbs the vertical vibration either by using a strong steel spring, or a resilient rubber element (Figure 11).

6.4 Subs (substitutes)

Subs are short joints of pipe which act as crossovers (i.e. connect components which cannot otherwise be screwed together because of differences in thread type or size).

6.5 Drilling Jars

The purpose of these tools is to deliver a sharp blow to free the pipe if it becomes stuck in the hole. Hydraulic jars are activated by a straight pull and give an upward blow. Mechanical jars are preset at surface to operate when a given compression load is applied and give a downward blow. Jars are usually positioned at the top of the drill collars.

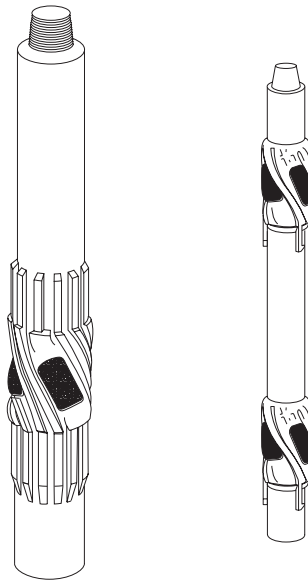

Figure 10 Roller reamers

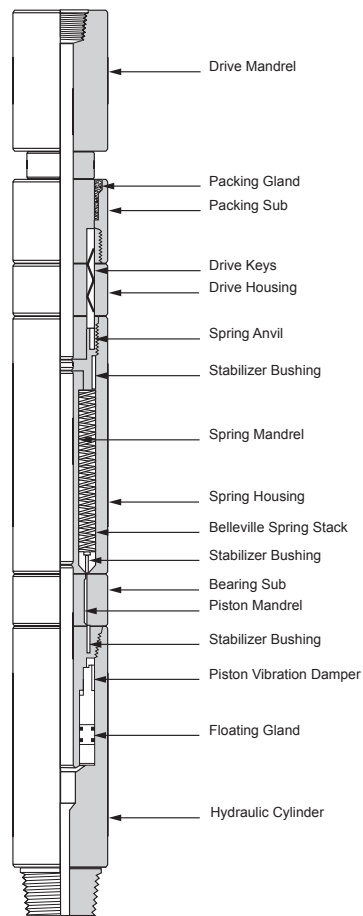

Figure 11 Shock sub

7. DRILL STRING DESIGN

There are four basic requirements which must be met when designing a drillstring:

- The burst, collapse and tensile strength of the drillstring components must not be exceeded
- The bending stresses within the drill string must be minimised.
- The drillcollars must be able to provide all of the weight required for drilling.
- The BHA must be stabilised to control the direction of the well.

7.1. Design of a Stabilised String

A drilling bit does not normally drill a vertical hole. This is partly due to the forces acting on the string by sloping laminar formations. When the slope (or **dip**) of the beds is less than 45 degrees the bit tends to drill up-dip (perpendicular to the layers). If the dip is greater than 45 degrees it tends to drill parallel to the layers (see Figure 12). In hard rock, where greater WOB is applied, the resulting compression and bending of the drillstring may cause further deviation. There are two techniques for controlling deviation.

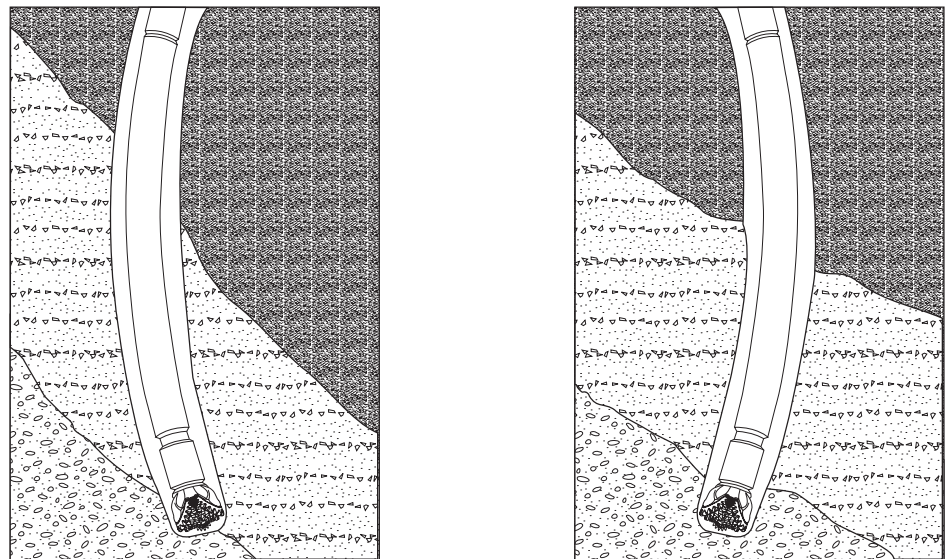

Figure 12 Drilling through dipping strata

- **Packed hole assembly** (Figure 13) - This is basically a stiff assembly, consisting of reamers, drill collars and stabilisers. The purpose of this design is to align the bit with the hole already drilled and minimise the rate of change in deviation.
- **Pendulum assembly** - The first stabiliser of a pendulum assembly is placed some distance behind the bit. The unsupported section of drill collar (Figure 13) swing to the low side of the hole. A pendulum assembly will therefore tend to decrease the angle of deviation of the hole and tend to produce a vertical hole. This will tend to reduce deviation. The distance “L” from the bit up to the point of wall contact is important, since this determines the pendulum force. To increase this distance, a stabiliser can be positioned some distance above the bit. If placed too high the collars will sag against the hole and reduce the pendulum force. The optimum position for

the stabiliser is usually based on experience, although theoretical calculations can be done. When changing the hole angle it must be done smoothly to avoid dog legs (abrupt changes in hole angle). The method of calculating dog leg severity will be given later. Some typical Bottom hole assemblies (BHA), for different drilling conditions, are given in Figure 14.

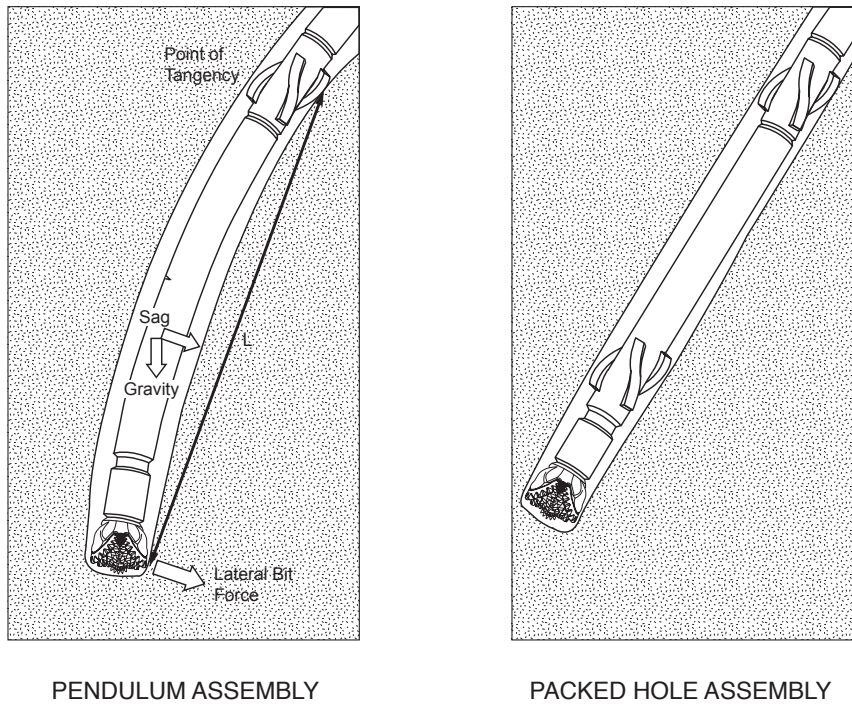

Figure 13 Pendulum effect

the stabiliser is usually based on experience, although theoretical calculations can be done. When changing the hole angle it must be done smoothly to avoid dog legs (abrupt changes in hole angle). The method of calculating dog leg severity will be given later. Some typical Bottom hole assemblies (BHA), for different drilling conditions, are given in Figure 14.

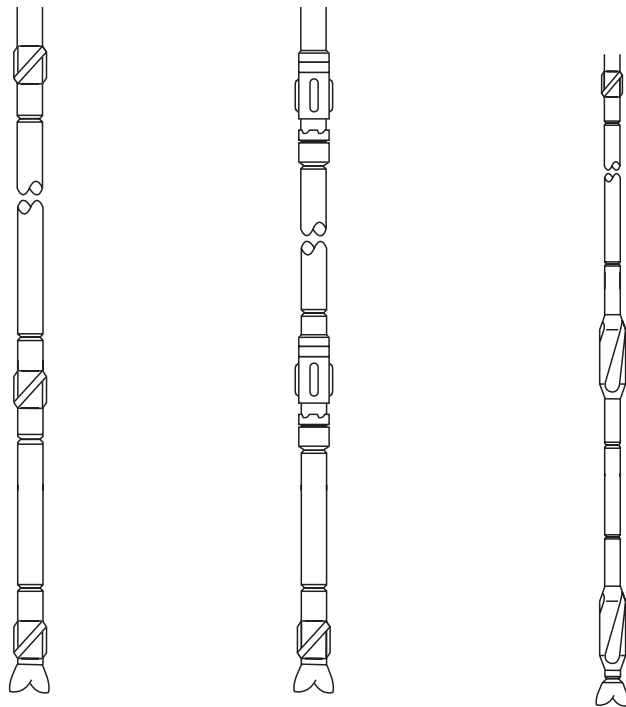

Figure 14 Typical BHA's

7.2 Bending Moments in String Design

A useful parameter when considering bending of the drillstring is the:

$$\text{section modulus} = \frac{I}{C} \quad \frac{\text{Moment of Inertia}}{\text{External radius of tube}}$$

Field results have shown that if the ratio of section modulus between various string components is kept below 5.5 the failure rate is reduced. The section modulus ratio for a variety of drillpipe sizes is given in Table 8. In larger holes, or more severe drilling conditions, the ratio should be kept below 3.5 (Table 10). Essentially these guidelines will eliminate abrupt changes in cross sectional area throughout the drillstring. The selection of suitable HWDP's to run above collars is simplified by Figure 16, which gives guidelines based on the extent of deviation in the hole.

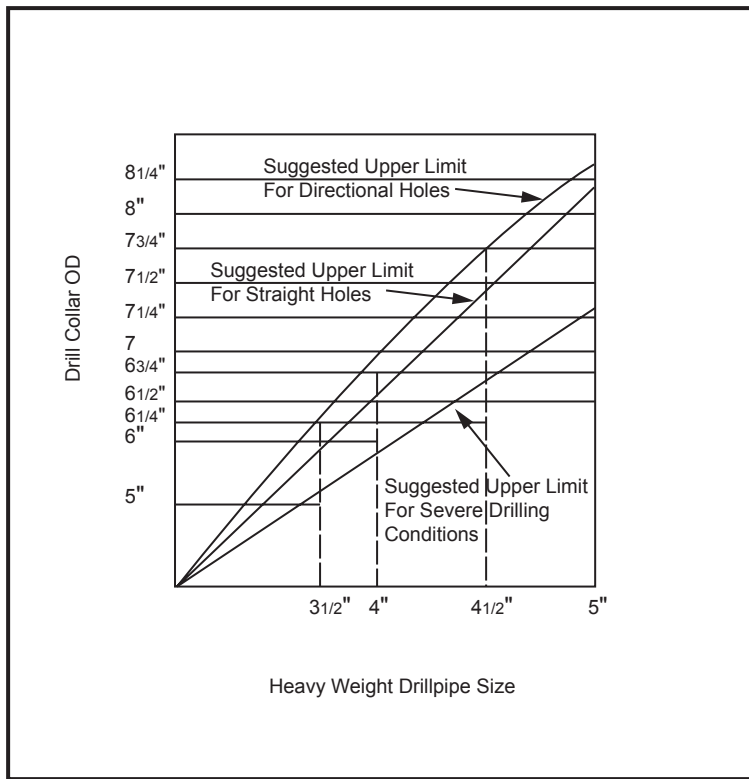

Figure 15 Typical BHAs for straight hole drilling

Section Modulus Values		
Pipe O.D. inches	Nominal pipe weight pounds per foot	I/C
2 3/8	4.85	0.66
	6.65	0.87
2 7/8	6.85	1.12
	10.40	1.60
3 1/2	9.50	1.96
	13.30	2.57
	15.50	2.92
4	11.85	2.70
	14.00	3.22
	15.70	3.58
4 1/2	13.75	3.59
	216.60	4.27
	20.00	5.17
5	19.50	5.71
	25.60	7.25

Table 8 I/C Data for drillstring components

7.3 Length of Drillcollars

The length of drillcollars, L that are required for a particular drilling situation depends on the Weight on Bit, WOB that is required to optimise the rate of penetration of the bit and the *bouyant* weight per foot, w of the drillcollars to be used, and can be calculated from the following:

$$L = \text{WOB}/w$$

If the drillpipe is to remain in tension throughout the drilling process, drillcollars will have to be added to the bottom of the drillstring. The bouyant weight of these additional drillcollars must exceed the bouyant force on the drillpipe

This will be sufficient to ensure that when the entire weight of the drillcollars is allowed to rest on the bit, then the optimum weight on bit will be applied. The WOB will however vary as the formation below the bit is drilled away, and therefore the length of the drillcollars is generally increased by an additional 15%. Hence the length of drillcollars will be $1.15L$.

Exercise 3 Length of Drillcollars for a given WOB

You have been advised that the highest rate of penetration for a particular 12 1/4" bit will be achieved when 25,000lbs weight on bit (WOB) is applied to the bit. Assuming that the bit will be run in 12 ppg mud, calculate the length of drillcollars required to provide 25,000 lbs WOB.

- a. Calculate the weight (in air) of 10000 ft of 5" 19.5 lb/ft Grade G drillpipe with 4 1/2" IF connections.
 - b. Calculate the weight of this string in 12 ppg mud.
 - c. Calculate the length of 9 1/2" x 2 13/16" drillcollars that would be required to provide 25,000lbs WOB and keep the drillpipe in tension in 12 ppg mud.
-

7.4 Drill Pipe Selection

The main factors considered in the selection of drillpipe are the collapse load, and the tensile load on the pipe. Burst pressures are not generally considered since these only occur when pressuring up the string on a plugged bit nozzle or during a DST, but it is very unlikely that the burst resistance of the pipe will be exceeded. Torsion need not be considered except in a highly deviated well.

Once the collapse and tension load have been quantified, the appropriated weight and grade of drillpipe can be selected.

Collapse Load

The highest external pressure tending to collapse the string will occur at the bottom when the string is run empty into the hole. (This only occurs when running a



Drillstem Test - DST tool). If a non-return valve is run (preventing upward flow of fluid into the drillpipe) it is normally standard practice to fill up the pipe at regular intervals when running in. The highest anticipated external pressure on the pipe is given by

$$P_c = 0.052 \times MW \times TVD$$

where:

P_c = collapse pressure (psi)

MW = mud weight (ppg)

TVD = true vertical depth (ft) at which P_c acts

This assumes that there is no fluid inside the pipe to resist the external pressure (i.e. no back up). The collapse resistance of new and used drillpipe are given in Tables 11 and 12. The collapse resistance of the drillpipe is generally derated by a design factor (i.e. divide the collapse rating by 1.125). A suitable grade and weight of drill pipe must be selected whose derated collapse resistance is greater than P_c . This string must then be checked for tension.

Tension Load

The tensile resistance of drill pipe, as given in Table 11 and 12 is usually derated by a design factor (i.e. divide the tension rating by 1.15). The tension loading can be calculated from the known weights of the drill collars and drill pipe below the point of interest.

The effect of buoyancy on the drillstring weight, and therefore the tension, must also be considered. Buoyancy forces are exerted on exposed horizontal surfaces and may act upwards or downwards. These exposed surfaces occur where there is a change in cross-sectional area between different sections (Figure 16). By starting at the bottom of the string and working up to the top, the tension loading can be determined for each depth. This is represented graphically by the tension loading line (Figure 16).

If the drillpipe is to remain in tension throughout the drilling process, drillcollars will have to be added to the bottom of the drillstring. The buoyant weight of the drillcollars must exceed the buoyant force on the drillpipe and the neutral point shown in Figure 16 must be within the length of the drillcollars. The drillcollars required to provide WOB discussed above must be added to the drillcollars required to maintain the drillstring in tension.

When selecting the drillpipe, the maximum tensile load that the string could be subjected to will have to be considered. In addition to the design load calculated on the basis of the string hanging freely in the wellbore the following safety factors and margins are generally added:

- Design Factor - a design factor is generally added to the loading line calculated above (multiply by 1.3). This allows for extra loads due to rapid acceleration of the pipe.

- **Margin of Overpull** - a “margin of overpull” (MOP) is generally added to the loading line calculated above. This allows for the extra forces applied to the drill string when pulling on stuck pipe. The MOP is the tension in excess of the drill string weight which is exerted. The MOP may be 50,000 - 100,000 lbs.

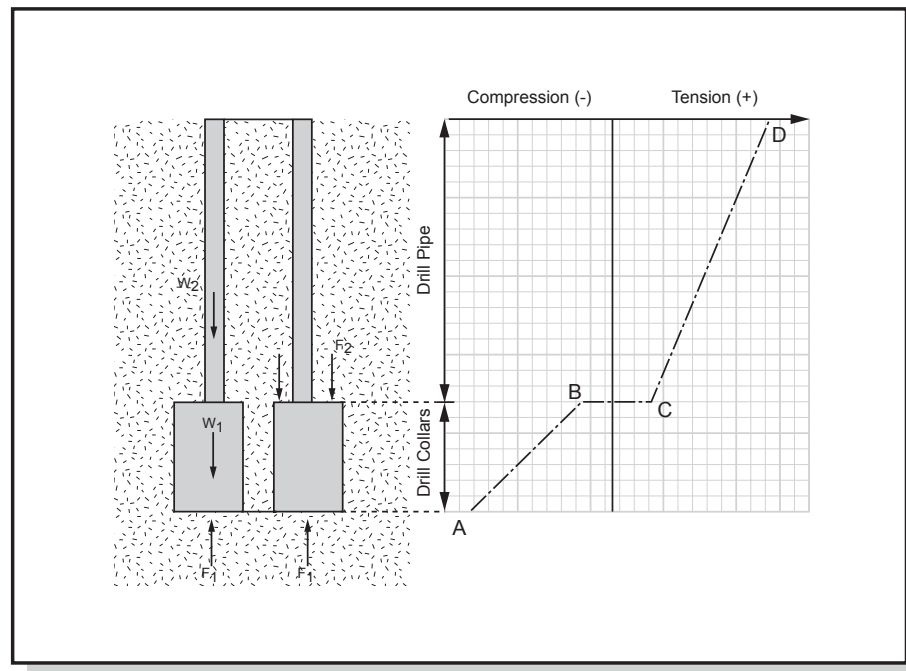

Figure 16 Axial Load on the Drillstring

- **Safety Factor** - a safety factor for slip crushing is generally added to the loading line calculated above. This allows for the interaction of hoopstress (S_h) caused by the slips and the tensile stress (S_t) caused by the weight of the string. This effect reduces the allowable tension load by a factor (S_h/S_t) which can be calculated as follows:

$$\frac{S_h}{S_t} = \left[1 + \frac{DK}{2L} + \left(\frac{DK}{2L} \right)^2 \right]^{1/2}$$

where:

- D = O.D. of pipe (in)
- L = length of slips (in)
- K = lateral load factor

Slips are normally either 12 in. or 16 in. long, and for normally lubricated slips $K = 4.00$. Table 9 gives a direct result for S_h/S_t , but this assumes new pipe. If used pipe is being considered the actual D must be measured and S_h/S_t calculated from the above equation. Having obtained this factor it is applied to the tension loading line.



7.4 Design Procedure

A graphical approach to drillstring design is recommended. If one section of the string does not meet requirements it must be upgraded. The procedure is as follows:

1. Choose a weight and grade of pipe to satisfy the collapse conditions
2. Using the pipe chosen in 1. calculate the tension loading, including buoyancy effects. Draw the tension loading line and also the maximum allowable load line.
3. Modify the tension load as given in 2. by applying a design factor, MOP and S_h/S_t factor. Three design lines are thus generated.
4. If any of these design lines exceed the maximum allowable load, a higher rated drillpipe must be used for that section of pipe.
5. Calculate the new tension loading line for the new drill string and repeat steps 3. and 4.

Design Example :

Design a 5" 19.5 lb/ft drill string using new pipe to reach a TD of 12000 ft in a vertical hole. The BHA consists of 20 drill collars 6 1/4" x 2 13/14" (82.6 lb/ft) each 30 ft long. For design purposes assume the following:

MW = 10 ppg
 MOP = 100000 lbs
 Length of slips = 12"
 Design factors = 1.125 (collapse)
 = 85% (tension)

1. Collapse loading
 at 12000' $P_c = 0.052 \times 10 \times 12000 = 6240$ psi

From Table 11

OD	Grade	Wt	Collapse rating
5"	E	19.5 lb/ft	10000 = 8889 psi (x 1.125)
5"	E	25.6 lb/ft	13500 = 12000 psi (x 1.125)

choose: 19.5 lb/ft grade E drill pipe (ID = 4.276")

2. Tension loading line (Figure 17)

at 12000' $F_1 = (P \times A)$

where: $P = 0.052 \times 10 \times 12000 = 6240$ psi

$$A = \pi/4 (6.25^2 - 2.812^2) = 24.47 \text{in}^2$$

$$F_1 = (6240 \times 24.47) = 152693 \text{ lbs}$$

$$W_1 = 20 \times 30 \times 82.6 = 49560 \text{ lbs}$$

$$\text{at } 11400' \quad F_2 = (P \times A)$$

$$\text{where: } P = 0.052 \times 10 \times 11400 = 5928 \text{ psi}$$

$$A = \pi/4 (6.25^2 - 5^2) + \pi/4 (4.276^2 - 2.8125^2) = 19.19 \text{ in}^2$$

$$F_2 = (5928 \times 19.19) = 113758 \text{ lbs.}$$

$$W_2 = 11400 \times 19.5 = 222300 \text{ lbs (Nominal weight used as approximation)}$$

Calculating the tension at the top and bottom of each section:

$$\text{at bottom of collars} \quad T = -152693 \text{ lbs}$$

$$\text{at top of collars} \quad T = -152693 + 49560 = -103133 \text{ lbs}$$

$$\text{at bottom of drill pipe} \quad T = -103133 + 113758 = 10625 \text{ lbs}$$

$$\text{at top of drillpipe} \quad T = 10625 + 222300 = 232925 \text{ lbs}$$

Plot these figures on a graph, along with the maximum allowable load
 $= 0.85 \times 395000 = 335750 \text{ lbs}$

3. Construct Design loading lines:

a. multiply actual loads by 1.3 to obtain the design loads (T_d)

$$\text{at surface } T_d = 1.3 \times 232925 = 302802 \text{ lbs}$$

$$\text{at } 11400' \quad T_d = 1.3 \times 10625 = 13812 \text{ lbs}$$

b. add 100000 MOP to obtain T_d

$$\text{at surface } T_d = 232925 + 100000 = 332925 \text{ lbs}$$

$$\text{at } 11400' \quad T_d = 10625 + 100000 = 110625 \text{ lbs}$$

c. apply slip crushing factor

$$\text{at surface } T_d = 1.59 \times 232925 = 370351 \text{ lbs}$$

$$\text{at } 11400' \quad T_d = 1.59 \times 10625 = 16894 \text{ lbs}$$

Plot these 3 design lines on Figure 17

4. Above 2000' the design loading line exceeds the maximum allowable tensile load, therefore a stronger section of pipe must be used from 0 - 2000'.

Choose 25.6 lb/ft grade E drill pipe.



5. Re-calculate tensile loading for new string and repeat 3. and 4. (Figure 18).

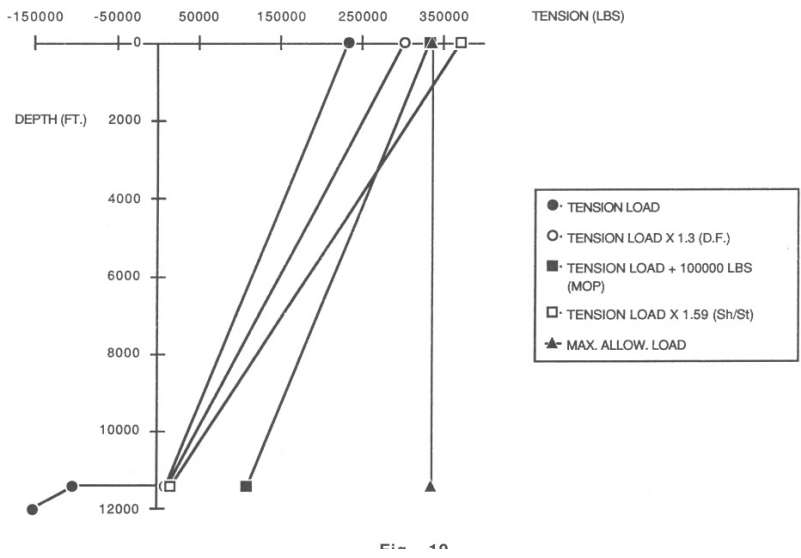

Figure 17 Calculated Tension Loading on Drillpipe

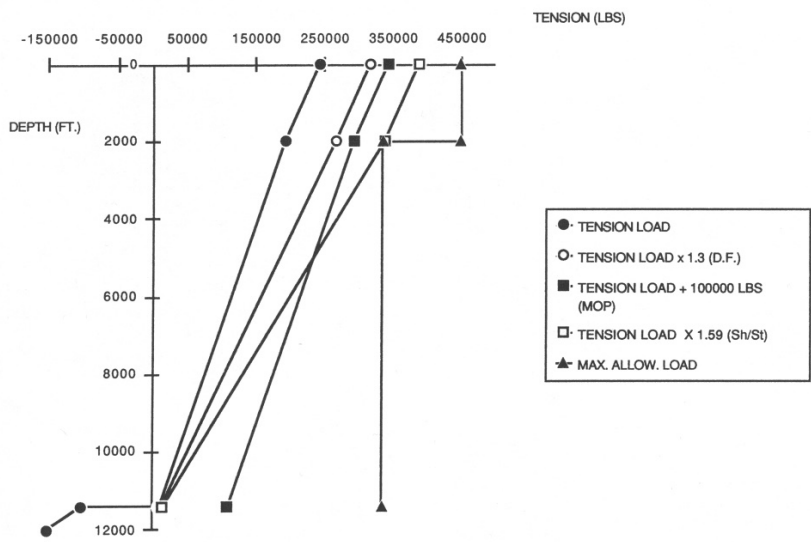

Figure 18 Revised Tension Loading on Drillpipe

6. Final design

0 - 2000' 25.6 lb/ft Grade E
 2000' - 11400' 19.5 lb/ft Grade E
 11400' - 12000' 6 1/4" x 2 13/16" collars

In practice two grades of drill pipe are usually available on the rig. In the North Sea 5", 19.5 lb/ft. grade E and 5", 19.5 lb/ft, grade G are common. The combination of these two grades plus HWDP will meet most requirements.

Slip Length	Coeff. of Friction	Lateral load-factor K	Pipe size - inches					
			2 ³ / ₈	2 ⁷ / ₈	3 ¹ / ₂	4	4 ¹ / ₂	5
			Safety Factor Sh/St					
	0.06	4.36	1.27	1.34	1.43	1.50	1.58	1.66
	0.08	4.00	1.25	1.31	1.39	1.45	1.52	1.59
12"	0.10	3.68	1.22	1.28	1.35	1.41	1.47	1.54
	0.12	3.42	1.21	1.26	1.32	1.38	1.43	1.49
	0.14	3.18	1.19	1.24	1.30	1.34	1.40	1.45
	0.06	4.36	1.20	1.24	1.30	1.36	1.41	1.47
16"	0.08	4.00	1.18	1.22	1.28	1.32	1.37	1.42
	0.10	3.68	1.16	1.20	1.25	1.29	1.34	1.38
	0.12	3.42	1.15	1.18	1.23	1.27	1.31	1.35
	0.14	3.18	1.14	1.17	1.21	1.25	1.28	1.32

Table 9 Lateral load factor of slips



Hole	DC/DP (ODxID)	I C	Ratio of I C	Remarks
17' "	DC 9' " x 3"	83.8	1.5	Not recommended
	DC 8 ¹ / ₄ " x 2 ¹³ / ₁₆ "	55.9	9.8	
	DP 5" x 4.276"	5.7		
17' "	DC 9' " x 3"	83.8	1.5	Not recommended
	DC 8 ¹ / ₄ " x 2 ¹³ / ₁₆ "	55.9	7.1	
	DP 5' " x 4.670"	7.8	1.4	
	DP 5" x 4.276"	5.7		
17' "	DC 9' " x 3"	83.8	1.5	OK for soft formations
	DC 8 ¹ / ₄ " x 2 ¹³ / ₁₆ "	55.9	5.2	
	HWDP 5" x 3"	10.9	1.9	
	DP 5" x 4.276"	5.7		
17' "	DC 9' " x 3"	83.8	1.5	OK for hard formations
	DC 8 ¹ / ₄ " x 2 ¹³ / ₁₆ "	55.9	2.5	
	DC 6 ¹ / ₄ " x 2 ¹³ / ₁₆ "	22.7	3.9	
	DP 5" x 4.276"	5.7		
12' "	DC 9' " x 3"	83.8	1.5	OK for hard formations
	DC 8 ¹ / ₄ " x 2 ¹³ / ₁₆ "	55.9	2.5	
	DC 6 ¹ / ₄ " x 2 ¹³ / ₁₆ "	22.7	3.9	
	DP 5" x 4.276"	5.7		
12' "	DC 9' " x 3"	83.8	1.5	OK for soft formations
	DC 8 ¹ / ₄ " x 2 ¹³ / ₁₆ "	55.9	5.2	
	HWDP 5" x 3"	10.7	1.9	
	DP 5" x 19.5"	5.7		
8' "	DC 6 ¹ / ₄ " x 2 ¹³ / ₁₆ "	22.7	3.9	OK
	DP 5" x 4.276"	5.7		
8' "	DC 6 ¹ / ₄ " x 2 ¹³ / ₁₆ "	22.7	2.1	
	HWDP 5" x 3"	10.7	1.9	
	DP 5" x 4.276"	5.7		

Table 10 Drillpipe/Drillcollar Combinations

NEW DRILL PIPE DATA					
SIZE O.D. in.	NOMINAL Wt. ft. lbs.	Grade E	Grade 95	Grade 105	Grade 135
TORSION: Torsional Yield Strength, ft.-lbs.					
3 _{1/2}	13.30	18,520	23,460	25,930	33,330
	15.50	21,050	26,660	29,470	37,890
4 _{1/2}	16.60	30,750	38,950	43,050	55,350
	20.00	36,840	46,660	51,570	66,300
5	19.50	41,090	52,050	57,530	73,970
	25.60	52,160	66,070	73,030	93,900
TENSION: Minimum Values Load at the Minimum Yield Strength, lbs.					
3 _{1/2}	13.30	271,570	343,990	380,190	488,820
	15.50	322,780	408,850	451,890	581,000
4 _{1/2}	16.60	330,560	418,700	462,780	595,000
	20.00	412,360	522,320	577,300	742,240
5	19.50	395,600	501,090	553,830	712,070
	25.60	530,140	671,520	742,200	954,260
COLLAPSE: Based on minimum values, psi.					
3 _{1/2}	13.30	14,110	17,880	19,760	21,170*
	15.50	16,770	21,250	23,480	25,150*
4 _{1/2}	16.60	10,390	12,750	13,820	15,590*
	20.00	12,960	16,420	18,150	19,440*
5	19.50	10,000	12,010	12,990	15,110*
	25.60	13,500	17,100	18,900	20,250*
BURST: Internal pressure at minimum yield strength, psi.					
3 _{1/2}	13.30	13,800	17,480	19,320	24,840
	15.50	16,840	21,330	23,570	30,310
4 _{1/2}	16.60	9,830	12,450	13,760	17,690
	20.00	12,540	15,890	17,560	22,580
5	19.50	9,500	12,040	13,300	17,110
	25.60	13,120	16,620	18,380	23,620
* According to A.P.I. RP 7G, 1970. Other data from 1971.					
USED DRILL PIPE DATA, A.P.I. "PREMIUM" CLASS					
Torsional Yield Strength, based on 20% Uniform Wear, ft.-lbs.					
3 _{1/2}	13.30	14,340	18,160	20,070	25,800
	15.50	16,120	20,420	22,560	29,010
4 _{1/2}	16.60	24,100	30,520	33,740	43,370
	20.00	28,630	36,270	40,090	51,540
5	19.50	32,230	40,820	45,120	58,010
	25.60	40,470	51,270	56,660	72,850
Minimum Yield Load, based on 20% Uniform Wear, lbs.					
3 _{1/2}	13.30	212,250	268,850	297,150	382,050
	15.50	250,500	317,300	305,700	450,900
4 _{1/2}	16.60	260,100	329,460	364,140	468,180
	20.00	322,950	409,070	452,130	581,310

Table 11 Ratings for New Drillpipe



USED DRILL PIPE DATA, A.P.I. CLASS 2*					
SIZE O.D. in.	NOMINAL Wt. ft. lbs.	Grade E	Grade 95	Grade 105	Grade 135
Torsional Yield Strength based on 35% eccentric wear, ft. -lbs.					
3 $\frac{1}{2}$	13.30	11,170	14,830	16,390	21,070
	15.50	13,160	16,670	18,430	23,690
4 $\frac{1}{2}$	16.60	19,680	24,920	27,550	35,420
	20.00	23,380	29,620	32,740	42,090
5	19.50	26,320	33,330	36,840	47,370
	25.60	33,050	41,870	46,270	59,490
Minimum Yield Load based on 20% Uniform Wear, lbs.					
3 $\frac{1}{2}$	13.30	212,250	268,850	297,150	382,050
	15.50	250,500	317,300	305,700	450,900
4 $\frac{1}{2}$	16.60	260,100	329,460	364,140	468,180
	20.00	322,950	409,070	452,130	581,310
5	19.50	311,400	394,440	435,960	560,520
	25.60	417,500	535,000	585,000	750,000
Minimum Collapse Pressure based on 65% Nominal Wall, psi.					
3 $\frac{1}{2}$	13.30	9,180	11,660	12,950	16,190
	15.50	11,000	13,970	15,520	19,400
4 $\frac{1}{2}$	16.60	5,660	7,020	7,700	9,060
	20.00	8,280	10,600	11,800	14,840
5	19.50	5,370	6,630	7,250	8,230
	25.60	8,770	11,140	12,380	15,470
Minimum Burst pressure based on 65% Nominal Wall, psi.					
3 $\frac{1}{2}$	13.30	10,240	12,970	14,340	18,440
	15.50	12,510	15,850	17,520	22,530
4 $\frac{1}{2}$	16.60	7,300	9,250	10,220	13,140
	20.00	9,330	11,820	13,070	16,800
5	19.50	7,080	8,970	9,910	12,740
	25.60	9,750	12,350	13,650	17,550

NOTE: The "Premium" - class pipe is recommended for service where it is anticipated that the torsional limits for Class 2 pipe will be exceeded.
 The data for Tension, Collapse and Burst are the same for "Premium" - class pipe as for Class 2 pipe.
 The data for Torque are different only.

* According to A.P.I. RP 7G

Table 12 Ratings for Class 2 Used Drillpipe

CAPACITY AND DISPLACEMENT OF DRILLPIPE

SIZE AND CONN.	NOMINAL WEIGHT LB/FT	GRADE	APPROX WEIGHT LB/FT	CAPACITY		OPEN END DISPLACEMENT		CLOSED END DISPLACEMENT	
				L/M	GALL/FT	L/M	GALL/FT	L/M	GALL/FT
2 ³ / ₈ 2 ³ / ₈ IF NC26	6.65	E75	7.00	1.68	0.135	1.39	0.107	3.01	0.242
		X95	7.08			1.34	0.108	3.02	0.243
		G105	7.08			1.34	0.108	3.02	0.243
2 ⁷ / ₈ 2 ⁷ / ₈ IF NC 31	10.4	E75	10.82	2.36	0.190	2.05	0.165	4.41	0.355
		X95	10.89			2.06	0.166	4.42	0.356
		G105	10.89			2.06	0.166	4.42	0.356
		S135	11.20			2.12	0.171	4.48	0.361
3 ¹ / ₂ 3 ¹ / ₂ IF NC38	9.5	E75	10.39	4.54	0.366	1.97	0.159	6.51	0.525
	13.3	E75	13.86	3.88	0.312	2.63	0.212	6.51	0.524
		X95	14.32	3.96	0.319	2.71	0.218	6.67	0.537
		G105	14.38	3.87	0.312	2.73	0.220	6.60	0.532
	15.5	E75	16.42	3.46	0.279	3.11	0.250	6.57	0.529
		X95	16.54			3.14	0.253	6.60	0.532
G105	16.61	3.15	0.254	6.61	0.533				
5 4 ¹ / ₂ IF NC50	19.5	E75	20.99	9.16	0.738	3.98	0.320	13.14	1.058
		X95	21.09			4.00	0.322	13.16	1.070
		G105	21.50			4.08	0.329	13.24	1.087
		S135	22.09			4.19	0.337	13.35	1.075
	25.6	E75	27.01	8.11	0.653	5.12	0.412	13.23	1.065
X95	28.30	8.10	0.652	5.36	0.432	13.46	1.084		
	G105	28.11	8.09	0.651	5.33	0.429	13.42	1.080	

Table 13 Specifications of Various Sizes of Drillpipe



DRILL COLLAR WEIGHTS (STEEL) POUNDS PER FOOT

Collar O.D.	BORE OF COLLAR											
	1-1/2	1-3/4	2	2-1/4	2-1/2	2-13/16	3	3-1/4	3-1/2	3-3/4	4	
3-3/8	24.4	22.2										
3-1/2	26.7	24.5										
3-3/4	31.5	29.3										
3-7/8	34.0	31.9	29.4	26.5								
4	36.7	34.5	32.0	29.2								
4-1/8	39.4	37.2	34.7	31.9								
4-1/4	42.2	40.0	37.5	34.7								
4-1/2	48.0	45.8	43.3	40.5								
4-3/4	54.2	52.0	49.5	46.7	43.5							
5	60.2	58.5	55.9	53.1	49.9	53.3						
5-1/4	67.5	65.3	62.8	59.9	56.8	60.5	56.7					
5-1/2	74.7	72.5	69.9	67.2	63.9	67.9	64.1					
5-3/4	82.1	79.9	77.5	74.6	71.5	75.8	71.9	63.3				
6	89.9	87.8	85.3	82.5	79.3	83.9	80.1	75.9	63.3			
6-1/4	98.1	95.9	93.5	90.6	87.5	92.5	88.6	84.5	79.9			
6-1/2	106.6	104.5	101.9	99.1	95.9	101.3	97.5	93.3	88.8			
6-3/4	115.5	113.3	110.8	107.9	104.8	110.5	106.6	102.5	97.9	93.1		
7	124.6	122.5	119.9	117.1	113.9	119.9	116.1	111.9	107.5	102.6	87.9	
7-1/4	134.1	131.9	129.5	126.6	123.5	129.8	125.9	121.8	117.3	112.5	97.5	
7-1/2	143.9	141.7	139.3	136.5	133.3	139.9	136.1	131.9	127.5	122.6	107.3	
7-3/4	154.1	151.9	149.5	146.6	143.5	149.9	146.6	142.5	137.9	133.1	117.5	
8	164.6	162.5	149.9	157.1	153.9	150.5	146.6	142.5	137.9	133.1	127.9	
8-1/4	175.4	173.3	170.8	167.9	164.8	161.3	157.5	153.3	148.8	143.9	138.8	
8-1/2	186.6	184.4	181.9	179.1	175.9	168.6	172.5	168.6	164.5	159.9	149.9	
8-3/4	198.1	195.9	193.9	190.6	187.4	183.9	180.1	175.9	171.4	166.6	161.5	
9		207.8	205.3	202.4	199.3	195.8	191.9	187.8	183.3	178.5	173.3	
9-1/2		232.4	229.9	227.1	223.9	220.4	216.6	212.4	207.9	203.1	197.9	
10			255.9	253.1	249.9	246.4	242.6	238.4	233.9	229.1	223.9	
10-1/2			283.3	280.4	277.3	273.8	269.9	265.8	261.3	256.4	251.3	
11					305.9	302.4	298.6	294.4	289.9	285.1	279.9	

lbs/ft = 2.67 (OD² - ID²)

Table 14 Drillcollar Weights

MUD DENSITY, GRADIENT AND BUOYANCY FACTOR

NOTE: Buoyancy factor is for STEEL only

Mud density			Gradient psi/ft	Buoyancy Factor	Mud density			Gradient psi/ft	Buoyancy Factor
kg/m ³	lb/gall	lb/ft ³			kg/m ³	lb/gall	lb/ft ³		
1000	8.34	62.4	.433	.873	1800	15.0	112	.779	.771
1010	8.40	62.8	.436	.872	1820	15.2	114	.790	.768
1030	8.50	64.3	.447	.869	1850	15.4	115	.800	.765
1060	8.80	65.8	.457	.866	1870	15.6	117	.810	.762
1080	9.00	67.3	.468	.862	1890	15.8	118	.821	.759
1100	9.20	68.8	.478	.860	1920	16.0	120	.831	.755
1130	9.40	70.3	.488	.856	1940	16.2	121	.842	.753
1150	9.60	71.8	.499	.853	1970	16.4	123	.852	.749
1154	9.625	72.0	.500	.853	1990	16.6	124	.862	.746
1180	9.80	73.3	.509	.850	2010	16.8	126	.873	.743
1200	10.0	74.8	.519	.847	2040	17.0	127	.883	.740
1220	10.2	76.3	.530	.844	2060	17.2	129	.894	.737
1250	10.4	77.8	.540	.841	2090	17.4	130	.904	.734
1270	10.6	79.3	.551	.838	2110	17.6	132	.914	.731
1290	10.8	80.8	.561	.835	2130	17.8	133	.925	.728
1320	11.0	82.3	.571	.832	2160	18.0	135	.935	.725
1340	11.2	83.8	.582	.829	2180	18.2	136	.945	.722
1370	11.4	85.3	.592	.826	2210	18.4	138	.956	.719
1390	11.6	86.8	.603	.823	2230	18.6	139	.966	.716
1410	11.8	88.3	.613	.820	2250	18.8	141	.977	.713
1440	12.0	89.8	.623	.817	2280	19.0	142	.987	.710
1460	12.2	91.3	.634	.814	2300	19.2	144	.997	.707
1490	12.4	92.8	.644	.810	2330	19.4	145	1.01	.704
1510	12.6	94.3	.655	.808	2350	19.6	147	1.02	.701
1530	12.8	95.8	.665	.804	2370	19.8	148	1.03	.698
1560	13.0	97.3	.675	.801	2400	20.0	150	1.04	.694
1580	13.2	98.7	.686	.798	2420	20.2	151	1.05	.692
1610	13.4	100	.696	.795	2450	20.4	153	1.06	.688
1630	13.6	102	.706	.792	2470	20.6	154	1.07	.685
1650	13.8	103	.717	.789	2490	20.8	156	1.08	.682
1680	14.0	105	.727	.786	2520	21.0	157	1.09	.679
1700	14.2	106	.738	.783	2540	21.2	159	1.10	.676
1730	14.4	108	.748	.780	2570	21.4	160	1.11	.673
1750	14.6	109	.758	.777	2590	21.6	162	1.12	.670
1770	14.8	111	.769	.774	2610	21.8	163	1.13	.667

Table 15 Buoyancy Factors



Solutions to Exercises

Exercise 1 Dimensions and weight of drillpipe

- a. The weight (in air) of 30 ft of 5" 19.5 lb/ft Grade G drillpipe with 4 1/2" IF connections:

$$\begin{aligned} & 21.5 \text{ lb/ft (Approx. wt.)} \times 30 \text{ ft} \\ & = 645 \text{ lbs} \end{aligned}$$

- b. The weight of this string in 12 ppg mud:

$$\begin{aligned} & 645 \text{ lbs} \times 0.817 \text{ (buoyancy factor)} \\ & = 527 \text{ lbs} \end{aligned}$$

Exercise 2 Drillcollar dimensions and weights

- a. The weight (in air) of 200 ft of 9 1/2" x 2 13/16" drillcollar is:

$$\begin{aligned} & 220.4 \text{ lb/ft (Approx. wt.)} \times 200 \text{ ft} \\ & = 44080 \text{ lbs} \end{aligned}$$

- b. The weight of this string in 13 ppg mud:

$$\begin{aligned} & 44080 \text{ lbs} \times 0.801 \text{ (buoyancy factor)} \\ & = 35308 \text{ lbs} \end{aligned}$$

c.

5" 19.5 lb/ft drillpipe	I.D. = 4.276"
8 1/4" x 2 13/16" drillcollars	I.D. = 2 13/16"

Exercise 3 Length of Drillcollars for a given WOB

- a. The weight (in air) of 10,000 ft of 5" 19.5 lb/ft Grade G drillpipe with 4 1/2" IF connections:

$$\begin{aligned} & 21.5 \text{ lb/ft (Approx. wt.)} \times 10,000 \text{ ft} \\ & = 215,000 \text{ lbs} \end{aligned}$$

- b. The weight of this string in 12 ppg mud:

$$\begin{aligned} & 215,000 \text{ lbs} \times 0.817 \text{ (buoyancy factor)} \\ & = 175,655 \text{ lbs} \end{aligned}$$

- c. The length of 9 1/2" x 2 13/16" drillcollars that would be required to provide 25,000 lbs WOB in 12 ppg mud:

$$\frac{25,000 \text{ lbs}}{220.4 \text{ lb/ft} \times 0.817} = 139 \text{ ft}$$

An additional length of drillcollars is required to ensure that the drillpipe is in tension when drilling. This additional length of collars will be required to overcome the buoyant force on the drillpipe and from the above will be equal to:

$$\frac{(215000 - 175655)}{220.4 \times 0.817} = 219 \text{ ft}$$

With an additional 15% length of drillcollar the total length of collar will be:

$$(139 \times 1.15) + 219 = 379 \text{ ft}$$

Drilling Bits⁴

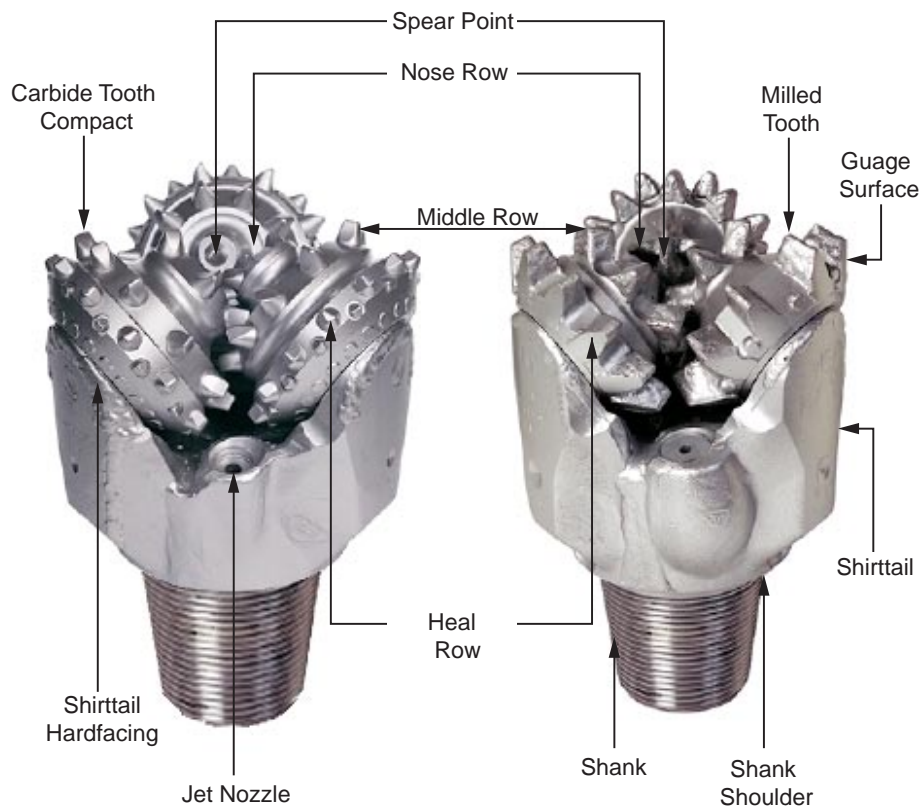

CONTENTS

1. TYPES OF DRILLING BIT

- 1.1. Drag Bits
- 1.2. Roller Cone Bits
- 1.3. Diamond Bits
 - 1.3.1 Natural Diamond Bits
 - 1.3.2 PDC Bits
 - 1.3.3 TSP Bits

2. BIT DESIGN

- 2.1. Roller Cone Bit Design
 - 2.1.1. Bearing Assembly
 - 2.1.2. Cone Design
 - 2.1.3. Cutting Structure
 - 2.1.4. Fluid Circulation
- 2.2. PDC Bit Design
 - 2.2.1. Cutter Material
 - 2.2.2. Bit Body Material
 - 2.2.2. Bit Body Material
 - 2.2.4. Profile
 - 2.2.5. Cutter Density
 - 2.2.6. Cutter Exposure
 - 2.2.7. Fluid Circulation

3. BIT SELECTION

- 3.1. Roller Cone Bits
- 3.2. Fixed Cutter Bits

4. ROCK BIT EVALUATION

5. BIT PERFORMANCE

- 5.1. Roller Cone Bits
 - 5.1.1. Weight on Bit
 - 5.1.2. Rotary Speed
 - 5.1.3. Mud Properties
- 5.2. PDC Bits
 - 5.2.1. WOB/RPM
 - 5.2.2. Mud Properties
 - 5.2.3. Hydraulic Efficiency





LEARNING OBJECTIVES:

Having worked through this chapter the student will be able to:

General:

- Describe the basic types of drillbit and the differences between a Diamond, Roller Cone and a PDC Bit

Roller Cone Bit Design:

- List the main characteristics which are considered in the design of roller cone bits.
- Describe the: various types of bearing; design features of the cones; and types of nozzles used in roller cone bits.

PDC Bit Design:

- List the main characteristics which are considered in the design of PDC bits
- Describe the: cutting material; body material; cutter rake; bit profile; cutter density; cutter exposure; and fluid circulation features in PDC and TSP bits
- Describe the differences between PDC and TSP bits.

Bit Selection:

- Describe the process of roller cone bit selection and the bit selection charts.
- Describe the fixed cutter bit selection process and the selection charts used for these bits.

Bit Evaluation:

- State the value of having an evaluation technique for drillbits.
- Describe the main causes of damage to bits.
- Describe the bit evaluation process and the IADC evaluation system.
- Grade a dull bit using the IADC dull grading system

Bit Performance:

- Describe the techniques used to evaluate the performance of a drillbit.
- Calculate the cost per foot of a bit run and describe the ways in which the cost per foot calculation can be used to evaluate the performance of a bit run.
- Select a bit on the basis of previous bit run data.
- Describe the influence of various operating parameters on the performance of a bit.

INTRODUCTION

A drilling bit is the cutting or boring tool which is made up on the end of the drillstring (Figure 1). The bit drills through the rock by scraping, chipping, gouging or grinding the rock at the bottom of the hole. Drilling fluid is circulated through passageways in the bit to remove the drilled cuttings. There are however many variations in the design of drillbits and the bit selected for a particular application will depend on the type of formation to be drilled. The drilling engineer must be aware of these design variations in order to be able to select the most appropriate bit for the formation to be drilled. The engineer must also be aware of the impact of the operating parameters on the performance of the bit. The performance of a bit is a function of several operating parameters, such as: weight on bit (WOB); rotations per minute (RPM); mud properties; and hydraulic efficiency. This chapter of the course will therefore present the different types of drillbit used in drilling operations and the way in which these bits have been designed to cope with the conditions which they will be exposed to. An understanding of the design features of these bits will be essential when selecting a drillbit for a particular operation. Since there are a massive range of individual bit designs the drillbit manufacturers have collaborated in the classification of all of the available bits into a **Bit Comparison Chart**. This chart will be explained in detail.

When a section of hole has been drilled and the bit is pulled from the wellbore the nature and degree of damage to the bit must be carefully recorded. A system, known as the **Dull Bit Grading System**, has been devised by the **Association of Drilling Contractors - IADC** to facilitate this grading process. This system will also be described in detail.

In addition to selecting a bit, deciding upon the most suitable operating parameters, and then describing the wear on the bit when it has drilled a section of hole, the drilling engineer must also be able to relate the performance of the bit to the performance of other bits which have drilled in similar conditions. The technique used to compare bits from different wells and operations will also be described.

1. TYPES OF DRILLING BIT

There are basically three types of drilling bit (Figure 1)

- Drag Bits
- Roller Cone Bits
- Diamond Bits

1.1. Drag Bits

Drag bits were the first bits used in rotary drilling, but are no longer in common use. A drag bit consists of rigid steel blades shaped like a fish-tail which rotate as a single unit. These simple designs were used up to 1900 to successfully drill through soft formations. The introduction of **hardfacing** to the surface of the blades and the design of fluid passageways greatly improved its performance. Due to the dragging/scraping action of this type of bit, high RPM and low WOB are applied.

The decline in the use of drag bits was due to:

- The introduction of roller cone bits, which could drill soft formations more efficiently
- If too much WOB was applied, excessive torque led to bit failure or drill pipe failure
- Drag bits tend to drill crooked hole, therefore some means of controlling deviation was required
- Drag bits were limited to drilling through uniformly, soft, unconsolidated formations where there were no hard abrasive layers.

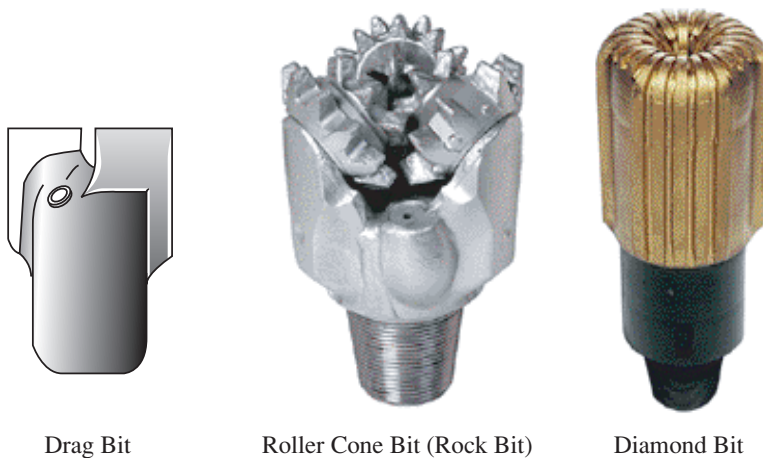

Figure 1 Types of drilling bit (Courtesy of Hughes Christensen)

1.2 Roller Cone Bits

Roller cone bits (or **rock bits**) are still the most common type of bit used world wide. The cutting action is provided by cones which have either steel teeth or tungsten carbide inserts. These cones rotate on the bottom of the hole and drill hole predominantly with a grinding and chipping action. Rock bits are classified as **milled tooth bits** or **insert bits** depending on the cutting surface on the cones (Figure 2 and 3).

The first successful roller cone bit was designed by Hughes in 1909. This was a major innovation, since it allowed rotary drilling to be extended to hard formations. The first design was a 2 cone bit which frequently balled up since the teeth on the cones did not mesh. This led to the introduction of a superior design in the 1930s which had 3 cones with meshing teeth. The same basic design is still in use today although there have been many improvements over the years.

The cones of the 3 cone bit are mounted on bearing pins, or arm journals, which extend from the bit body. The bearings allow each cone to turn about its own axis as the bit is rotated. The use of 3 cones allows an even distribution of weight, a balanced cutting structure and drills a better gauge hole than the 2 cone design. The major advances in rock bit design since the introduction of the Hughes rock bit include:

- Improved cleaning action by using jet nozzles
- Using tungsten carbide for hardfacing and gauge protection
- Introduction of sealed bearings to prevent the mud causing premature failure due to abrasion and corrosion of the bearings.

The elements of a roller cone bit are shown in detail in Figure 4.



Figure 2 Milled tooth bit (Courtesy of Hughes Christensen)



Figure 3 Insert bit (Courtesy of Hughes Christensen)

1.3 Diamond Bits

Diamond has been used as a material for cutting rock for many years. Since it was first used however, the type of diamond and the way in which it is set in the drill bit have changed.

1.3.1 Natural Diamond Bits

The hardness and wear resistance of diamond made it an obvious material to be used for a drilling bit. The diamond bit is really a type of drag bit since it has no moving cones and operates as a single unit. Industrial diamonds have been used for many years in drill bits and in core heads (Figure 1).



The cutting action of a diamond bit is achieved by scraping away the rock. The diamonds are set in a specially designed pattern and bonded into a matrix material set on a steel body. Despite its high wear resistance diamond is sensitive to shock and vibration and therefore great care must be taken when running a diamond bit. Effective fluid circulation across the face of the bit is also very important to prevent overheating of the diamonds and matrix material and to prevent the face of the bit becoming smeared with the rock cuttings (bit balling).

The major disadvantage of diamond bits is their cost (sometimes 10 times more expensive than a similar sized rock bit). There is also no guarantee that these bits will achieve a higher ROP than a correctly selected roller cone bit in the same formation. They are however cost effective when drilling formations where long rotating hours (200-300 hours per bit) are required. Since diamond bits have no moving parts they tend to last longer than roller cone bits and can be used for extremely long bit runs. This results in a reduction in the number of round trips and offsets the capital cost of the bit. This is especially important in areas where operating costs are high (e.g. offshore drilling). In addition, the diamonds of a diamond bit can be extracted, so that a used bit does have some salvage value.

1.3.2 PDC Bits

A new generation of diamond bits known as **polycrystalline diamond compact** (PDC) bits were introduced in the 1980's (Figure 5). These bits have the same advantages and disadvantages as natural diamond bits but use small discs of synthetic diamond to provide the scraping cutting surface. The small discs may be manufactured in any size and shape and are not sensitive to failure along cleavage planes as with natural diamond. PDC bits have been run very successfully in many areas around the world. They have been particularly successful (long bit runs and high ROP) when run in combination with *turbodrills* and oil based mud.

1.3.3 TSP Bits

A further development of the PDC bit concept was the introduction in the later 1980's of **Thermally Stable Polycrystalline** (TSP) diamond bits. These bits are manufactured in a similar fashion to PDC bits but are tolerant of much higher temperatures than PDC bits.

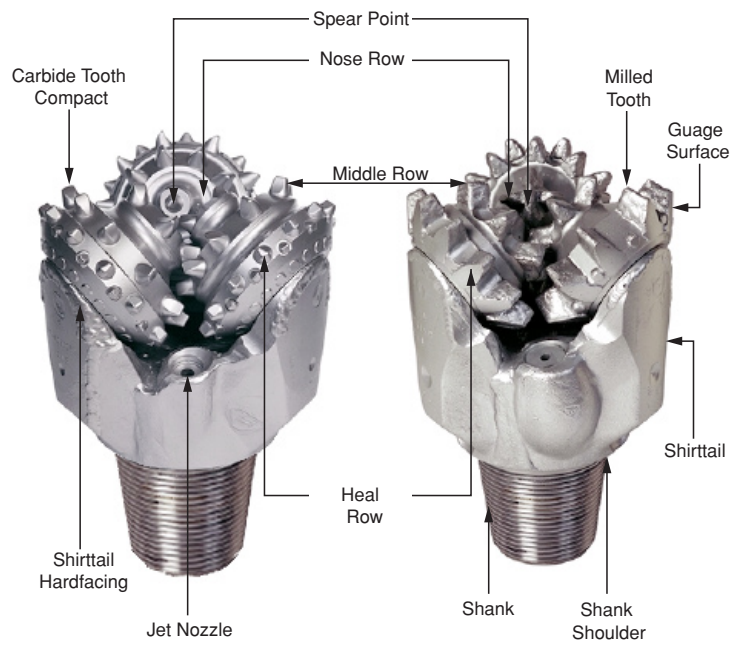

Figure 4 Elements of a rock bit (Courtesy of Hughes Christensen)

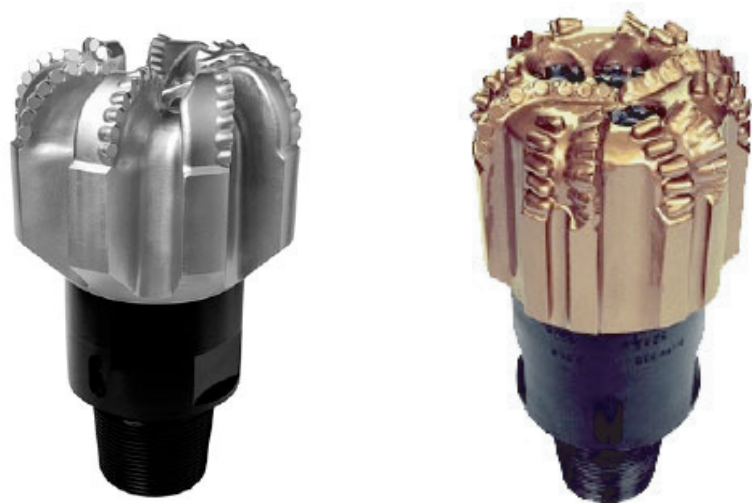

Figure 5 Polycrystalline Compact (PDC) Bits (Courtesy of Hughes Christensen)

2. BIT DESIGN

Roller Cone Bits and PDC Bits are the most widely used bits internationally and constitute virtually the entire bit market and therefore they are the only types of bits that will be discussed in detail in this section.

2.1 Roller Cone Bit Design

The design of roller cone bits can be described in terms of the four principle elements of their design. The following aspects of the design will be dealt with in detail:

- Bearing assemblies
- Cones
- Cutting elements
- Fluid circulation

2.1.1. Bearing Assembly

The cones of a roller cone bit are mounted on journals as shown in Figure 6. There are three types of bearings used in these bits:

- **Roller bearings**, which form the outer assembly and help to support the radial loading (or WOB)
- **Ball bearings**, which resist longitudinal or thrust loads and also help to secure the cones on the journals
- A **friction bearing**, in the nose assembly which helps to support the radial loading. The friction bearing consists of a special bushing pressed into the nose of the cone. This combines with the pilot pin on the journal to produce a low coefficient of friction to resist seizure and wear.

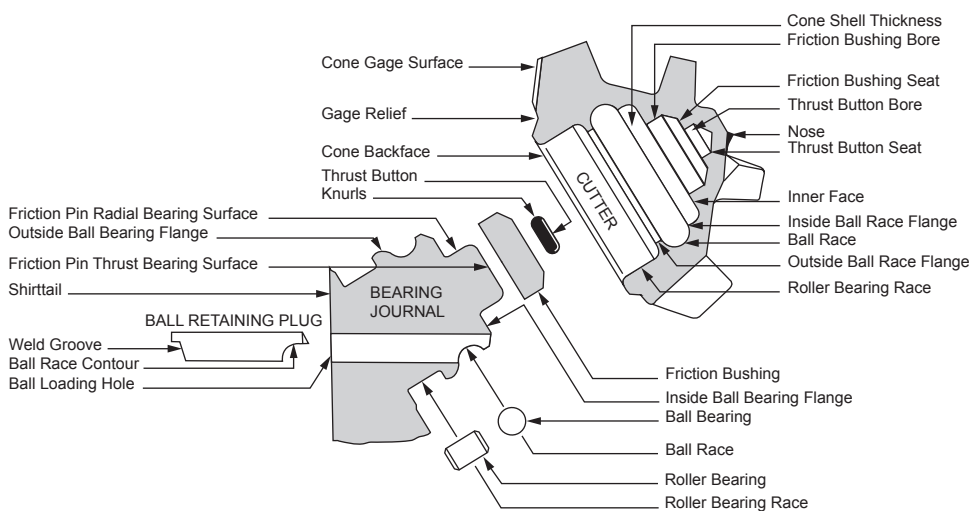

Figure 6 Details of bearing structure

All bearing materials must be made of toughened steel which has a high resistance to chipping and breaking under the severe loading they must support. As with all rock bit components, heat treatment is used to strengthen the steel.

The most important factor in the design of the bearing assembly is the space availability. Ideally the bearings should be large enough to support the applied loading, but this must be balanced against the strength of the journal and cone shell which will be a function of the journal diameter and cone shell thickness. The final design is a compromise which ensures that, ideally, the bearings will not wear out before the cutting structure (i.e. all bit components should wear out evenly). However, the cyclic loading imposed on the bearings will, in all cases, eventually initiate a failure. When this occurs the balance and alignment of the assembly is destroyed and the cones lock onto the journals.

There have been a number of developments in bearing technology used in rock bits :

The bearing assemblies of the first roller cone bits were open to the drilling fluid. **Sealed bearing bits** were introduced in the late 1950s, to extend the bearing life of insert bits. The sealing mechanism prevents abrasive solids in the mud from entering and causing excess frictional resistance in the bearings. The bearings are lubricated by grease which is fed in from a reservoir as required. Some manufacturers claim a 25% increase in bearing life by using this arrangement (Figure 7).

Journal bearing bits do not have roller bearings. The cones are mounted directly onto the journal (Figure 8). This offers the advantage of a larger contact area over which the load is transmitted from the cone to the journal. The contact area is specially treated and inlaid with alloys to increase wear resistance. Only a small amount of lubrication is required as part of the sealing system. Ball bearings are still used to retain the cones on the journal.

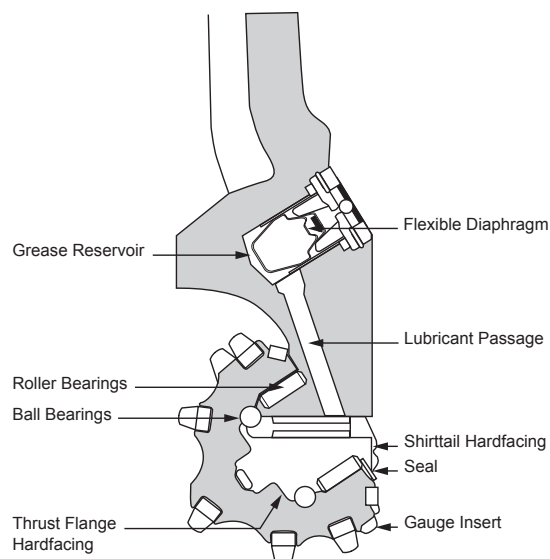

Figure7 Sealed bearing bit

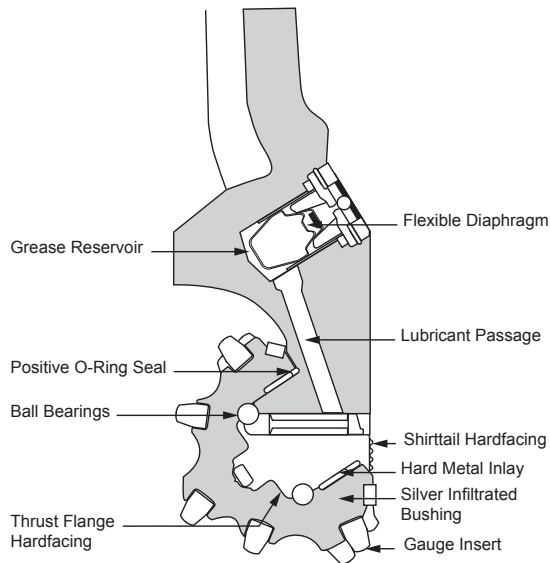

Figure 8 Journal bearing bit

2.1.2. Cone Design

All three cones have the same shape except that the No. 1 cone has a spear point. One of the basic factors to be decided, in the design of the cones, is the journal or pin angle (Figure 9). The journal angle is formed between the axis of the journal and the horizontal. Since all three cones fit together, the journal angle specifies the outside contour of the bit. The use of an oversize angle increases the diameter of the cone and is most suitable for soft formation bits. Although this increases cone size, the gauge tip must be brought inwards to ensure the bit drills a gauge hole.

One important factor which affects journal angle is the degree of meshing or interfit (i.e. the distance that the crests of the teeth of one cone extend into the grooves of the other). The amount of interfit affects several aspects of bit design.

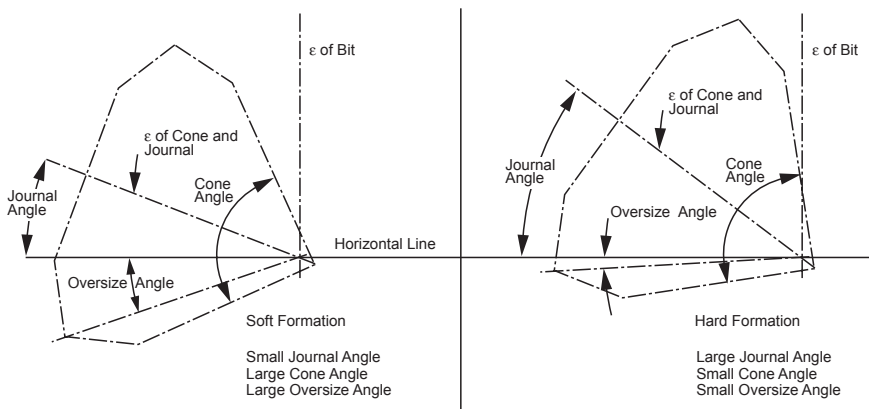

Figure 9 Journal or pin angle

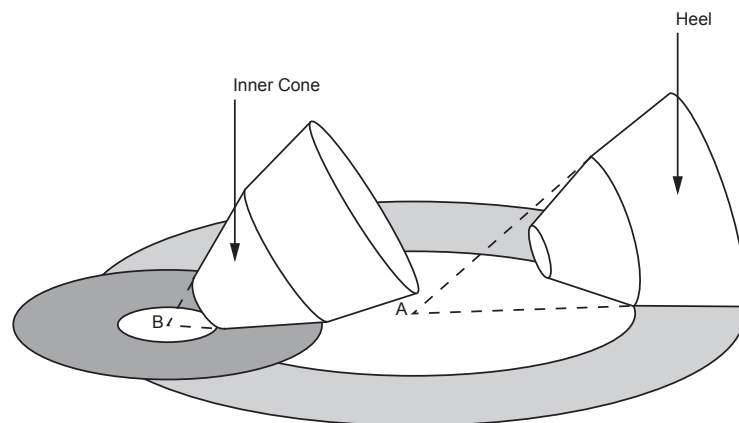

Figure 10 Cone slippage

- It allows increased space for tooth depth, more space for bearings and greater cone thickness
- It allows mechanical cleaning of the grooves, thus helping to prevent bit balling
- It provides space for one cone to extend across the centre of the hole to prevent coring effects
- It helps the cutting action of the cones by increasing cone slippage.

In some formations, it is advantageous to design the cones and their configuration so that they do not rotate evenly but that they slip during rotation. This *Cone slippage*, as it is called, allows a rock bit to drill using a scraping action, as well as the normal grinding or crushing action.

Cone slippage can be designed into the bit in two ways. Since cones have two profiles: the inner and the outer cone profile, a cone removed from the bit and placed on a horizontal surface can take up two positions (Figure 10). It may either roll about the heel cone or the nose cone. When the cone is mounted on a journal it is forced to rotate around the centre of the bit. This “unnatural” turning motion forces the inner cone to scrape and the outer cone to gouge. Gouging and scraping help to break up the rock in a soft formation but are not so effective in harder formations, where teeth wear is excessive.

Cone slippage can also be attained by **offsetting** the axes of the cones. This is often used in soft formation bits (Figure 11). To achieve an offset the journals must be angled slightly away from the centre. Hard formation bits have little or no offset to minimise slippage and rely on grinding and crushing action alone.

2.1.3 Cutting Structure

The teeth of a milled tooth bit and the inserts of an insert bit form the cutting structure of the bit. The selection of a milled tooth or insert bit is largely based on the hardness of the formation to be drilled. The design of the cutting structure will therefore be based on the hardness of the formation for which it will be used. The main considerations in the design of the cutting structure is the height and spacing of teeth or inserts.

Soft formation bits require deep penetration into the rock so the teeth are long, thin and widely spaced to prevent **bit balling**. Bit balling occurs when soft formations are drilled and the soft material accumulates on the surface of the bit preventing the teeth from penetrating the rock. The long teeth take up space, so the bearing size must be reduced. This is acceptable since the loading should not be excessive in soft formations.

Moderately hard formation bits are required to withstand heavier loads so tooth height is decreased, and tooth width increased. Such bits rely on scraping/gouging action with only limited penetration. The spacing of teeth must still be sufficient to allow good cleaning.

Hard formation bits rely on a chipping action and not on tooth penetration to drill, so the teeth are short and stubbier than those used for softer formations. The teeth must be strong enough to withstand the crushing/chipping action and sufficient numbers of teeth should be used to reduce the unit load. Spacing of teeth is less critical since ROP is reduced and the cuttings tend to be smaller.

The cutting structure for insert bits follows the same pattern as for milled tooth bits. Long chisel shaped inserts are required for soft formations, while short ovide shaped inserts are used in hard formation bits.

Tungsten carbide hardfacing is applied to the teeth of soft formation bits to increase resistance to the scraping and gouging action. Hard formation bits have little or no hardfacing on the teeth, but hardfacing is applied to the outer surface (gauge) of the bit. If the outer edge of the cutting structure is not protected by tungsten carbide hardfacing two problems may occur.

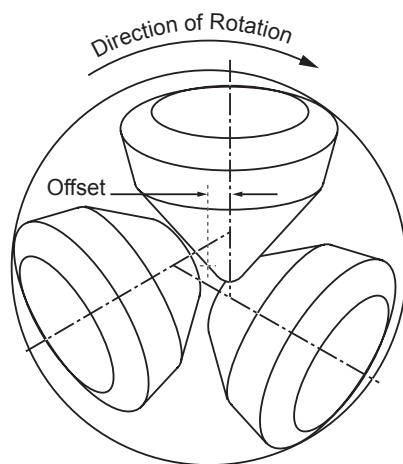

Figure 11 Offset in soft formation bits

- The outer surface of the bit will be eroded by the abrasive formation so that the hole diameter will decrease. This undergauge section of the hole will have to be reamed out by the next bit, thus wasting valuable drilling time

- If the gauge area is worn away it causes a redistribution of thrust forces throughout the bearing assembly, leading to possible bit failure and leaving junk in the hole (e.g. lost cones)

2.1.4 Fluid Circulation

Drilling fluid passes from the drillstring and out through nozzles in the bit. As it passes across the face of the bit it carries the drilled cutting from the cones and into the annulus. The original design for rock bits only allowed the drilling mud to be ejected from the middle of the bit (Figure 12). This was not very efficient and led to a build up of cuttings on the face of the bit (**bit balling**) and cone erosion. A more efficient method of cleaning the face of the bit was therefore introduced. The fluid is now generally ejected through three **jet nozzles** around the outside of the bit body (Figure 13). The turbulence created by the jet streams is enough to clean the cutters and allow efficient drilling to continue.

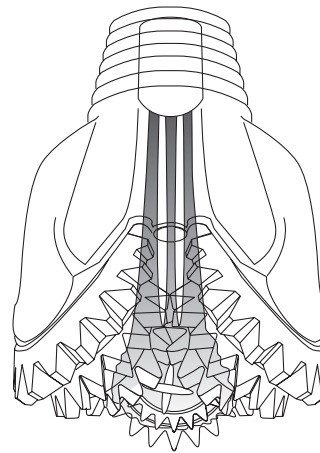

Figure 12 Fluid circulation through water courses

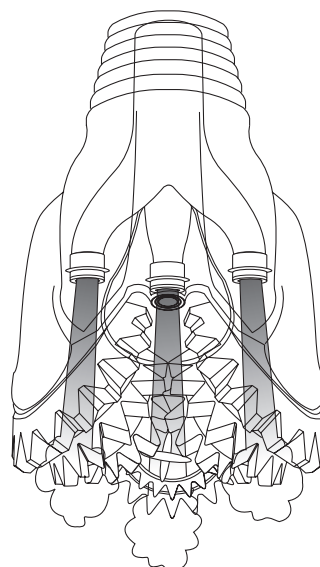

Figure 13 Fluid circulation through jet nozzles

Jet nozzles (Figure 15) are small rings of tungsten carbide and are available in many sizes. The outside diameter of the ring is standard so that the nozzle can fit into any bit size. The size of the nozzle refers to the inner diameter of the ring. Nozzles are available in many sizes although diameters of less than 7/32" are not recommended, since they are easily plugged. The nozzles are easily replaced and are fitted with an "O" ring seal (Figures 17). Extended nozzles (Figure 16) may also be used to improve the cleaning action. The nozzles are made of tungsten carbide to prevent fluid erosion.

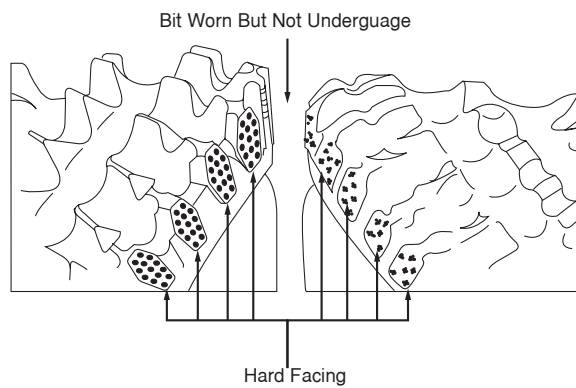

Figure 14 Hard facing for gauge protection

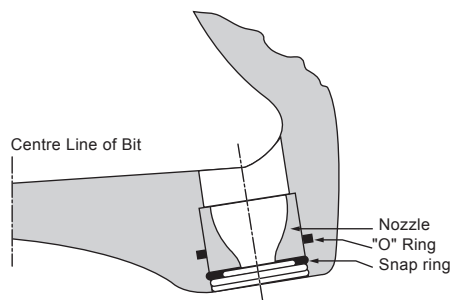

Figure 15 Jet nozzles

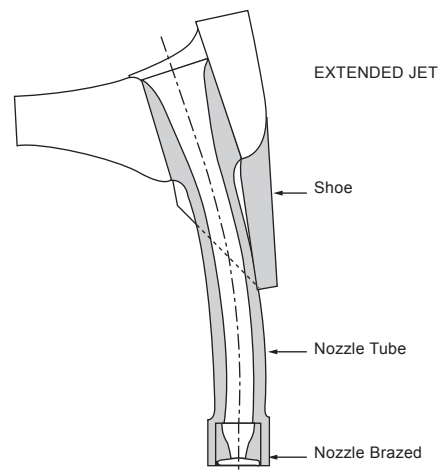

Figure 16 Extended nozzles

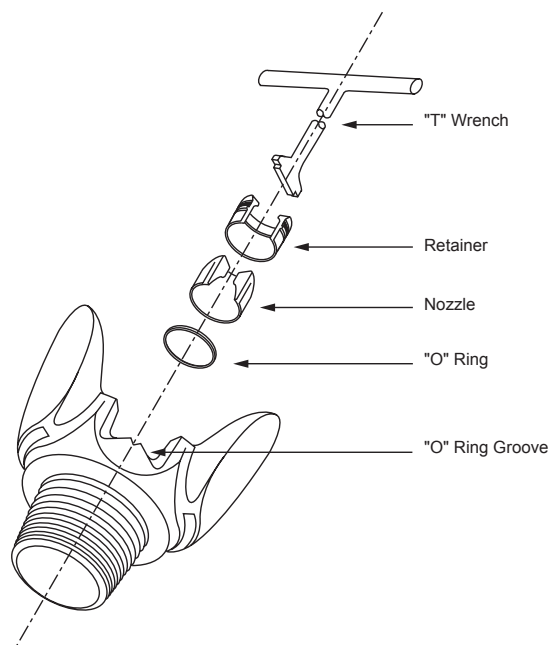

Figure 17 Nozzle wrench for installing nozzle and "O" ring

2.2 PDC Bit Design

The five major components of PDC bit design are

- Cutting Material
- Bit Body Material
- Cutter Rake
- Bit Profile
- Cutter Density
- Cutter Exposure
- Fluid Circulation



2.2.1 Cutter Material

The material used to manufacture the cutting surface on **Polycrystalline Diamond Compact - PDC** bits is called **Polycrystalline Diamond - PCD**. This synthetic material is 90-95% pure diamond and is manufactured into *compacts* which are set into the body of the bit. Hence the name of these bits. The high friction temperatures generated with these types of bits resulted in the polycrystalline diamond breaking up and this resulted in the development of **Thermally Stable Polycrystalline Diamond - TSP Diamond**.

PCD (Polycrystalline Diamond) is formed in a two stage high temperature, high pressure process. The first stage in the process is to manufacture the artificial diamond crystals by exposing graphite, in the presence of a Cobalt, nickel and iron or manganese catalyst/solution, to a pressure in excess of 600,000 psi. At these conditions diamond crystals rapidly form. However, during the process of converting the graphite to diamond there is volume shrinkage, which causes the catalyst/solvent to flow between the forming crystals, preventing intercrystalline bonding and therefore only a diamond crystal powder is produced from this part of the process.

In the second stage of the process, the PCD blank or 'cutter' is formed by a liquid-phase sintering operation. The diamond powder formed in the first stage of the process is thoroughly mixed with catalyst/binder and exposed to temperatures in excess of 1400^o C and pressures of 750,000 psi. The principal mechanism for sintering is to dissolve the diamond crystals at their edges, corners and points of high pressure caused by point or edge contacts. This is followed by epitaxial growth of diamond on faces and at sites of low contact angle between the crystals. This regrowth process forms true diamond-to-diamond bonds excluding the liquid binder from the bond zone. The binder forms a more or less continuous network of pores, co-existing with a continuous network of diamond. Typical diamond concentrations in the PCD is 90-97 vol.%.

If one requires a composite compact in which PCD is bonded chemically to a tungsten carbide substrate (Figure 18), some or all of the binder for the PCD may be obtained from the adjacent tungsten carbide substrate by melting and extruding the cobalt binder from the tungsten carbide. The cutters can be manufactured as disc shaped cutters or as stud cutters, as shown in Figure 19.

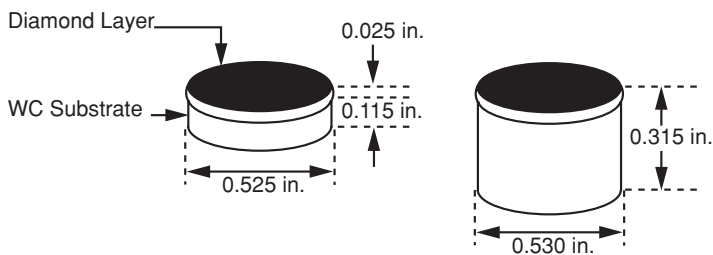

Figure 18 PDC cutters

Thermally Stable Polycrystalline - TSP - Diamond bits were introduced when it was found, soon after their introduction, that PDC bit cutters were sometimes chipped during drilling. It was found that this failure was due to internal stresses caused by the differential expansion of the diamond and binder material. Cobalt is the most widely used binder in sintered PCD products. This material has a thermal coefficient of expansion of 1.2×10^{-5} deg. C compared to 2.7×10^{-6} for diamond. Therefore cobalt expands faster than diamond. As the bulk temperature of the cutter rises above 730°C internal stresses caused by the different rates of expansion leads to severe intergranular cracking, macro chipping and rapid failure of the cutter.

These temperatures are much higher than the temperatures to be found at the bottom of the borehole (typically 100°C at 8000 ft). They, in fact, arise from the friction generated by the shearing action by which these bits cut the rock.

This temperature barrier of 730°C presented serious barriers to improved performance of PCD cutter bits. Manufacturers experimented with improving the thermal stability of the cutters and **Thermally Stable Polycrystalline Diamond Bits** were developed. These bits are more stable at higher temperatures because the cobalt binder has been removed and this eliminates internal stresses caused by differential expansion. Since most of the binder is interconnected, extended treatment with acids can leach most of it out. The bonds between adjacent diamond particles are unaffected, retaining 50-80% of the compacts' strength. Leached PCD is thermally stable in inert or reducing atmospheres to 1200°C but will degrade at 875°C in the presence of oxygen. Due to the nature of the manufacturing process the thermally stable polycrystalline (TSP) diamond cannot be integrally bonded to a WC substrate. Therefore, not only is the PCD itself weaker, but the excellent strength of an integrally bonded Tungsten Carbide (WC) substrate is sacrificed. Without the WC substrate, the TSP diamond is restricted to small sizes (Figure 20) and must be set into a matrix similar to natural diamonds.

2.2.2 Bit Body Material

The cutters of a PDC bit are mounted on a bit body. There are two types of bit body used for PDC bits. One of these is an entirely steel body and the other is a steel shell with a Tungsten Carbide matrix surface on the body of the shell.

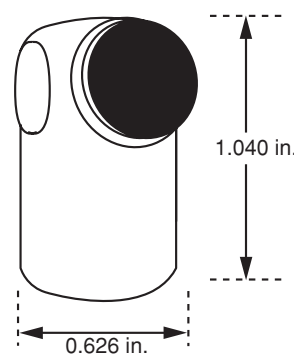

Figure 19 PDC stud cutter

The cutters on a **steel body bit** are manufactured as studs (Figure 19). These are interference fitted into a receptacle on the bit body. Tungsten carbide button inserts can also be set into the gauge of the bit to provide gauge protection. The stud can be set with a fixed **backrake** and/or **siderake** (see below). An advantage of using a stud is that it may be removed and replaced if the cutter is damaged and the body of the bit is not damaged. The use of a stud also eliminates the need for a braze between the bit body and the cutter. Field experience with the steel body bit indicates that face erosion is a problem, but this has been overcome to some extent by application of a hardfacing compound. Steel body bits also tend to suffer from broken cutters as a result of limited impact resistance (Figure 20). This limited impact resistance is because there is no support to the stud cutter.

Matrix body bits use the cylindrical cutter (Figure 18) that is brazed into a pocket after the bit body has been furnished by conventional diamond bit techniques. The advantage of this type of bit is that it is both erosion and abrasion resistant and the matrix pocket provides impact resistance for the cutter. Matrix body bits have an economic disadvantage because the raw materials used in their manufacture are more expensive.

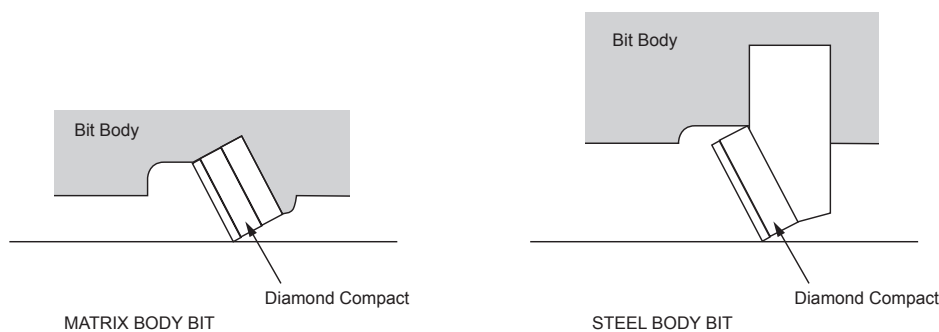

Figure 20 Setting of cutters

2.2.3 Cutter Rake

The PDC cutters can be set at various rake angles. These rake angles include **back rake** and **side rake**. The back rake angle determines the size of cutting that is produced. The smaller the rake angle the larger the cutting and the greater the ROP for a given WOB. The smaller the rake angle, however, the more vulnerable the cutter is to breakage should hard formations be encountered. Conversely the larger the rake angle the smaller the cutting but the greater resistance to cutter damage. Back rake also assists cleaning as it urges the cuttings to curl away from the bit body thereby assisting efficient cleaning of the bit face. Side rake is used to direct the formation cuttings towards the flank of the bit and into the annulus.

2.2.4 Profile

There are three basic types of PDC bit crown profile: flat or shallow cone; tapered or double cone; and parabolic. There are variations on these themes but most bits can be classified into these categories.

The flat or shallow cone profile evenly distributes the WOB among each of the cutters on the bit (Figure 21). Two disadvantages of this profile are limited rotational stability and uneven wear. Rocking can occur at high RPM, because of the flat profile. This can cause high instantaneous loading, high temperatures and loss of cooling to the PDC cutters.

The taper or double cone profile (Figure 22) allows increased distribution of the cutters toward the O.D. of the bit and therefore greater rotational and directional stability and even wear is achieved.

The parabolic profile (Figure 23) provides a smooth loading over the bit profile and the largest surface contact area. This bit profile therefore provides even greater rotational and directional stability and even wear. This profile is typically used for motor or turbine drilling.

2.2.5 Cutter Density

The cutter density is the number of cutters per unit area on the face of the bit. The cutter density can be increased or decreased to control the amount of load per cutter. This must however be balanced against the size of the cutters. If a high density is used the cutters must be small enough to allow efficient cleaning of the face of the bit.

2.2.6 Cutter Exposure

Cutter exposure is the amount by which the cutters protrude from the bit body. It is important to ensure that the exposure is high enough to allow good cleaning of the bit face but not so high as to reduce the mechanical strength of the cutter. High exposure of the cutter provides more space between the bit body and the formation face, whilst low exposure provides good backup and therefore support to the cutters.

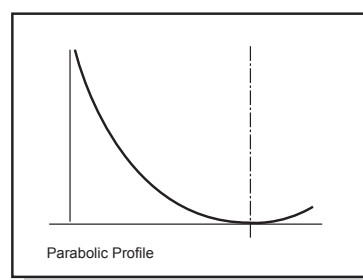

Figure 21 PDC Bit Shallow cone profile

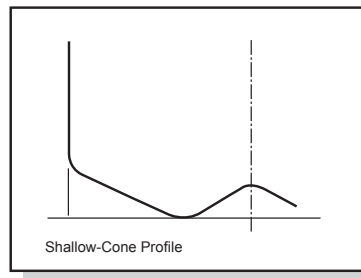

Figure 22 PDC Bit Taper or double cone profile

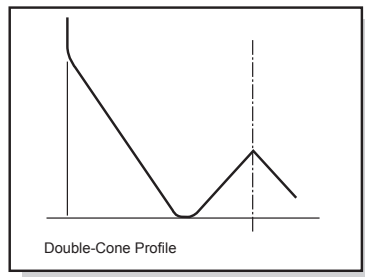

Figure23 PDC Bit Parabolic profile

2.2.7 Fluid Circulation

The fluid circulation across the bit face must be designed to remove the cuttings efficiently and also to cool the bit face. These requirements may be satisfied by increasing the fluid flowrate and/or the design of the water courses that run across the face of the bit. This increased fluid flow may however cause excessive erosion of the face and premature bit failure. More than three jets are generally used on a PDC bit.

3. BIT SELECTION

It can be appreciated from the above discussion that there are many variations in the design of drillbits. The IADC has therefore developed a system of comparison charts for classifying drillbits according to their design characteristics and therefore their application. Two systems have been developed: one for roller cone bits; and one for Fixed Cutter bits.

3.1 Roller Cone Bits :

The IADC bit comparison charts (Table 1) are often used to select the best bit for a particular application. These charts contain the bits available from the four leading manufacturers of bits. The bits are classified according to the **International Association of Drilling Contractors (IADC)** code. The position of each bit in the chart is defined by three numbers and one character. The sequence of numeric characters defines the “Series, Type and Features” of the bit. The additional character defines additional design features.

Column 1 - Series

The series classification is split into two broad categories: milled tooth bits (series 1-3); and insert bits (series 4-8). The characters 1- 8 represent a particular formation drillability.

Series 1-3 bits are therefore milled tooth bits which are suitable for soft, medium or hard formations.

Series 4-8 bits are insert bits and are suitable for soft, medium, hard and extra hard formations.

Column 2 - Type

Each series category is subdivided into 4 types according to the drillability of the formation (i.e. a type 3 is suitable for a harder formation than a type 2 bit within the same series).

The classification of the bit according to series and type specification will be dependant primarily on the cutter size and spacing and bearing and cone structure discussed in the previous sections.

Row 1 - Features

The design features of the bit are defined on the horizontal axis of the system. There are slight variations in the features described on the comparison charts, depending on the comparison chart being used in the chart shown in Table 1 the numerical characters define the following features:

- 1 Means a standard roller bearing
- 2 Means air cooled roller bearings
- 3 Means a roller bearing bit with gauge protection
- 4 Means sealed roller bearings are included
- 5 Means both sealed roller bearings and gauge protection included
- 6 Means sealed friction bearings included (for both milled tooth and insert bits)
- 7 Means both sealed friction bearings and gauge protection included

Additional Table - Additional Design Features

An additional Table is supplied with the bit classification chart. This table defines additional features of the bit. Eleven characters are used to describe features such as: extended nozzles; additional nozzles; suitability for air drilling etc.

If a bit is classified as 1-2-4-E this means that it is a soft formation, milled tooth bit with sealed roller bearings and extended nozzles.

The terms “soft” “medium” and “hard” formation are very broad categorisations of the geological strata which is being penetrated. In general the rock types within each category can be described as follows:



-
- **Soft formations** are unconsolidated clays and sands. These can be drilled with a relatively low WOB (between 3000-5000 lbs/in of bit diameter) and high RPM (125-250 RPM). Large flow rates should be used to clean the hole effectively since the ROP is expected to be high. Excessive flow rates however may cause washouts. Flow rates of 500-800 gpm are recommended. As with all bit types, local experience plays a large part in deciding the operating parameters.
 - **Medium formations** may include shales, gypsum, shaley lime, sand and siltstone. Generally a low WOB is sufficient (3000-6000 lbs/in of bit diameter). High rotary speeds can be used in shales but chalk requires a slower rate (100-150 RPM). Soft sandstones can also be drilled within these parameters. Again high flow-rates are recommended for hole cleaning
 - **Hard formations** may include limestone, anhydrite, hard sandstone with quartic streaks and dolomite. These are rocks of high compressive strength and contain abrasive material. High WOB may be required (e.g. between 6000-10000 lbs/in of bit diameter). In general slower rotary speeds are used (40-100 RPM) to help the grinding/crushing action. Very hard layers of quartzite or chert are best drilled with insert or diamond bits using higher RPM and less WOB. Flow rates are generally not critical in such formations. A more detailed description of formation types and suitable bits is given in Table 2 and 3.

FORMATION	BIT TYPE	CUTTING STRUCTURE	OFFSET AND PIN ANGLE	BEARING SIZE AND CONE SHELL THICKNESS
SOFT Low compressive strength, high drillability, with some hard streaks e.g. clays, soft shale, chalk.	1-1-1 1-2-1 1-2-3 1-3-1 1-3-1	long teeth, widely spaced	maximum offset, pin angle designed for gouging action to give high ROP	small bearings, thin cone shell to allow for longer teeth
MEDIUM HARD Alternate layers of more consolidated rock, e.g. sandy shales, sand, limestone	2-1-1 2-1-3 2-3-1 2-3-3	shorter teeth, spaced closer together to provide resistance to breakage	medium offset and pin angle to combine gouging and chipping action	larger bearings and shell thickness to take heavier WOB
HARD High compressive strength, abrasive formations, e.g. dolomite, hard limestone, chert	3-1-3 3-2-3 3-3-3	short stubby teeth, closely packed for crushing action	minimum offset to give true rolling action i.e. no scraping/gouging only crushing action	larger bearings, thick shells to take high WOB to drill through hard abrasive, formation

Table 2 Milled Tooth Bits

FORMATION	BIT TYPE	CUTTING STRUCTURE	OFFSET PIN ANGLE	BEARING SIZE CONE THICKNESS
SOFT Unconsolidated formations, low compressive strength e.g. slays, shales	5-5-7 5-3-7 5-4-7	maximum extension of tooth shaped inserts, widely spaced	pin angle designed to give scraping and crushing action	small bearings and thin cone shell to accommodate long inserts
MEDIUM Softer segments of hard formations e.g. lime, sandy shale	6-1-7 6-2-7	wedge shaped inserts with reduced extension	pin angle reduced to give more crushing action, with some gouging effect	thicker shell to give more protection
HARD Rocks of higher compressive strength e.g. dolomite, chert	7-3-7 7-4-7	wedge shaped inserts closely spaced	offset reduced to give more crushing/grinding effect, very little scraping	thicker shell, larger bearings

Table 3 Insert Bits

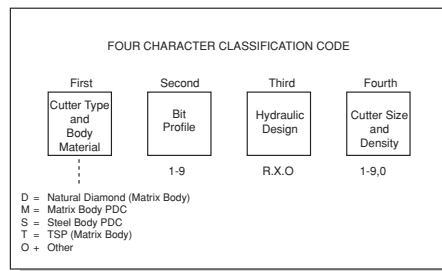

The 1987 IADC Fixed Cutter Bit Classification Standard

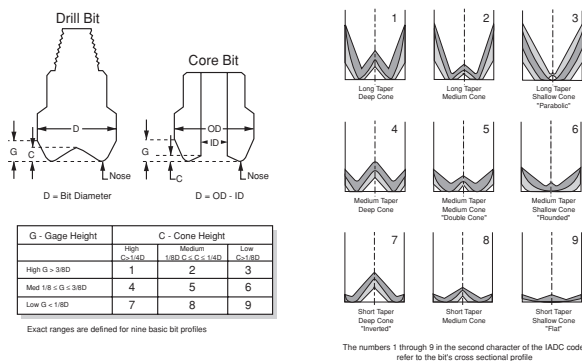

Table 4 PDC Bit Selection Chart

	Changeable Jets	Fixed Port	Open Throat
Bladed	1	2	3
Ribbed	4	5	6
Open Faced	7	8	9

ALTERNATE CODES
 R - Radial Flow
 X - Cross Flow
 O - Other

The numbers 1 through 9 in the third character of the IADC code refers to the bit's hydraulic design.
 The letters R, X and O apply to some types of open throat bits

Hydraulic Design

Density			
SIZE	Light	Medium	Heavy
Large	1	2	3
Medium	4	5	6
Small	7	8	9

O - Impregnated

CUTTER SIZE	NATURAL DIAMONDS stones per carat	NATURAL DIAMONDS usable cutter height
Large	<3	>5/8"
Medium	3-7	3/8" - 5/8"
Small	>7	<3/8"

Notes: 1 Cutter Density is determined by the manufacturer.
 2 The numbers 1 through 9 and 0 in the fourth character of the IADC code refer to the cutter size and placement density on the bit

Cutter Size and Density

Table 4 (Contd.) PDC Bit Selection Chart

Exercise 1 Selection of a Drillbit

Using the IADC Bit Selection chart (Table 1) select a Type 1 - 2 - 6 bit from each manufacturer listed.

3.2 Fixed Cutter Bits

The fixed cutter bit (diamond, PDC, TSP) classification system was introduced by the IADC in 1987. The system is comprised of a four character classification code (Table 4) indicating a total of seven bit design features : Cutter type, Body material, Bit profile, Fluid discharge, Flow distribution, Cutter size, and Cutter density. These relate directly to the design features discussed in the previous sections. The four character code corresponds to the following :

Column 1 - Primary Cutter Type and Body Material

Five letters are used to describe the cutter type and body material, as shown in Table 4. The distinction of "Primary" is used because one diamond material type will often be used as the primary cutting structure whilst another is used as backup.



Column 2 - Cross sectional Profile

The numbers 1 - 9 are used to define the bits' cross sectional profile, according to the 3 x 3 chart shown in Table 4. The term profile is used here to describe the cross section of the cutter/bottom hole pattern. This distinction is made because the cutter/bottom hole pattern may not be identical to the bit body profile.

Column 3 - Hydraulic Design

The numbers 1 - 9 in the third character of the system refers to the hydraulic design of the bit, according to the 3 x 3 chart in Table 4. This design is described by two components: the type of fluid outlet and the flow distribution.

Column 4 - Cutter Size and Placement Density

The numbers 1 - 9 in the fourth character of the system refers to the cutter size and placement density, according to the 3 x 3 matrix chart shown in Table 4.

4. ROCK BIT EVALUATION

As each bit is pulled from the hole its physical appearance is inspected and graded according to the wear it has sustained. The evaluation of bits is useful for the following reasons:

- To improve bit type selection
- To identify the effects of WOB, RPM, etc., which may be altered to improve the performance of the next bit
- To allow drilling personnel to improve their ability to recognise when a bit should be pulled (i.e. to correlate the performance of a bit downhole with its physical appearance on surface)
 - To evaluate bit performance and help to improve their design

A bit record (Table 5) will always be kept by the operating company, drilling contractor and/or bit vendor. This bit record is used to store the following information about the bit after it has completed its run:

- The bit size type and classification
- The operating parameters
- The condition of the bit when pulled
- The performance of the bit

The IADC Dull Grading system has recently been revised (1987) so that it may be applied to **all types of bit - roller cone or fixed cutter** (PDC, Diamond). The system is based on the chart shown in Figure 24 and will be described in terms of each column :

Column 1 - Cutting Structure Inner Row (I) :

Report the condition of the cutting structure on the inner 2/3 rds of the bit for roller cone bits and inner 2/3 rds radius of a fixed cutter bit (Figure 24)



IADC DULL BIT GRADING



CUTTING STRUCTURE		BEARINGS/ SEALS	GAGE	OTHER DULL CHAR.	REASON PULLED
INNER	OUTER				
(1)	(2)	(5)	(6)	(7)	(8)

ORDER CODE #6300-2/3M

(1) INNER CUTTING STRUCTURE (All inner rows.)

(2) OUTER CUTTING STRUCTURE (Gage row only)
In columns 1 and 2 a linear scale from 0 to 8 is used to describe the condition of the cutting structure according to the following:

STEEL TOOTH BITS
A measure of lost tooth height due to abrasion and/or damage.
0 - NO LOSS OF TOOTH HEIGHT
8 - TOTAL LOSS OF TOOTH HEIGHT.

INSERT BITS
A measure of total cutting structure reduction due to lost, worn and/or broken inserts.
0 - NO LOST, WORN AND/OR BROKEN INSERTS.
8 - ALL INSERTS LOST, WORN AND/OR BROKEN.

FIXED CUTTER BITS
A measure of lost, worn and/or broken cutting structure.
0 - NO LOST, WORN AND/OR BROKEN CUTTING STRUCTURE.
8 - ALL OF CUTTING STRUCTURE LOST, WORN AND/OR BROKEN.

(3) DULL CHARACTERISTICS
(Use only cutting structure related codes.)

- BC - Broken Cone
- BT - Broken Teeth/Cutters
- BU - Blurred Up Bit
- CC - Cracked Cone
- CD - Cone Draggled
- CI - Cone Interference
- CR - Cored
- CT - Chipped Teeth/Cutters
- ER - Erosion
- FC - Flat Crested Wear
- HC - Heat Checking
- JD - Junk Damage
- LC - Lost Cone
- LN - Lost Nozzle
- LT - Lost Teeth/Cutters
- OC - Oil Center Wear
- PR - Pinched Bit
- PN - Plugged Nozzle/Flow Passage
- RG - Rounded Gage
- RO - Ring Out
- SD - Shrinktail Damage
- SS - Self Sharpening Wear
- TR - Tracking
- WO - Washed Out Bit
- WT - Worn Teeth/Cutters
- NO - No Dull Characteristic

* Show row # or #s under location (4).

(4) LOCATION

ROLLER CONE
N - Nose Row
M - Middle Row
G - Gage Row
A - All Rows

CONC #
1
2
3

(5) BEARINGS / SEALS

NON-SEALED BEARINGS
A linear scale estimating bearing life used. (0 - No life used, 8 - All life used, ie. no bearing life remaining.)

(6) GAGE Measure in fractions of an inch.
I - In gage
1/16 - 1/16" out of gage
1/8 - 1/8" out of gage
1/4 - 1/4" out of gage

(7) OTHER DULL CHARACTERISTIC
Refer to column 3 codes.

(8) REASON PULLED OR RUN TERMINATED

BHA - Change Bottom Hole Assembly
DMF - Downhole Motor Failure
DSF - Drill String Failure
DST - Drill Stem Test
DP - Drill Plug
CM - Condition Mud
CP - Core Point
FM - Formation Change
HP - Hole Problems
LH - Lost in Hole

HR - Hours On Bit
LOG - Run Logs
PP - Pump Pressure
PR - Penetration Rate
RIG - Rig Repair
TD - Total Depth/Casing Depth
TW - Twist Off
TO - Trouble
WC - Weather Conditions

FOR INFORMATION ONLY CONTACT YOUR LOCAL SECURITY REPRESENTATIVE OR SECURITY DIVISION IN DALLAS, TEXAS. (714) 333-3211

Figure 24 IADC Dull Grading System (Courtesy of Security DBS)

Column 2 - Cutting Structure Outer Row (O)

Report the condition of the cutting structure on the outer 1/3 rd of the bit for roller cone bits and outer 1/3 rds radius of a fixed cutter bit (Figure 24). In column 1 and 2 a linear scale from 0 to 8 is used to describe the condition of the cutting structure as follows

STEEL TOOTH BITS : a measure of the lost tooth height.

0 - Indicates no loss of tooth height due to wear or breakage

8 - indicates total loss of tooth height due to wear or breakage

INSERT BITS : a measure of total cutting structure reduction due to lost, worn and/or broken inserts

0 - Indicates no lost, worn and/or broken inserts

8 - Indicates total loss of cutting structure due to lost, worn and/or broken inserts

FIXED CUTTER : a measure of the cutting structure wear (Figure 25)

0 - Indicates no loss of cutter or diamond height due to wear or breakage

8 - Indicates total loss of cutter or diamond height due to wear or breakage

Column 3 - Cutting Structure Dull Characteristics (D)

Report the major dull characteristics of the bit cutting structure based on the table shown in Figure 24

Column 4 - Cutting Structure Location (L)

Report the location on the face of the bit where the major cutting structure dulling characteristic occurs. This may be reported in the form of a letter or number code as shown in Figure 24. The location of dull characteristics for four fixed bit profiles is shown in Figure 25.

Column 5 - Bearing Condition (B)

Report the bearing condition of roller cone bits. The grading will depend on the type of bit. This space will always be occupied by an 'X' for fixed cutter bits.

NON - SEALED BEARING BITS : a linear scale from 0-8 to indicate the amount of bearing life that has been used :

0 - Indicates that no bearing life has been used (new bearing)

8 - Indicates that all of the bearing life has been used (locked or lost)

SEALED BEARING BITS : a letter scale to indicate the condition of the seal :

E - Indicates an effective seal

F - Indicates a failed seal

Column 6 - Gauge (G) :

Report on the gauge of the bit. The letter "I" is used if the bit has no gauge reduction. If the bit has gauge reduction it is reported in 1/16 ths of an inch.

Column 7 - Remarks (O) :

Report any dulling characteristic of the bit in addition to that reported for the cutting structure in column 3. Note that this is not restricted to only the cutting structure dull characteristic. The two letter codes to be used in this column are shown in Figure 24.

Column 8 - Reason for Pulling (R) :

Report the reason for pulling the bit out of the hole. This may be a two or three letter code as shown in Figure 24.



5. BIT PERFORMANCE

The performance of a bit may be judged on the following criteria:

- How much footage it drilled (ft)
- How fast it drilled (ROP)
- How much it cost to run (the capital cost of the bit plus the operating costs of running it in hole) per foot of hole drilled .

Since the aim of bit selection is to achieve the lowest cost per foot of hole drilled the best method of assessing the bits' performance is the last of the above. This method is applied by calculating the cost per foot ratio, using the following equation:

$$C = \frac{C_b + (R_t + T_t)C_r}{F}$$

where:

C = overall cost per foot (\$/foot)

C_b = cost of bit (\$)

R_t = rotating time with bit on bottom (hrs)

T_t = round trip time (hrs)

C_r = cost of operating rig (\$/hrs)

This equation relates the cost per foot of the bit run to the cost of the bit, the rate of penetration and the length of the bit run. It can be used for:

- Post drilling analysis to compare one bit run with another in a similar well.
- Real-time analysis to decide when to pull the bit. The bit should be pulled theoretically when the cost per foot is at its minimum.

Since penetration rate is one of the most significant factors in the assessment of bit performance this will be studied in greater depth.

5.1 Roller Cone Bits

In addition to correct bit selection penetration rate is a function of many parameters:

- Weight on Bit (WOB)
- Rotary speed (RPM)
- Mud properties
- Hydraulic efficiency

5.1.1 Weight on Bit

A certain minimum WOB is required to overcome the compressibility of the formation. It has been found experimentally that once this threshold is exceeded, penetration rate increases linearly with WOB (Figure 26). There are however certain limitations to the WOB which can be applied:

a. Hydraulic horsepower (HHP) at the bit

If the HHP at the bit is not sufficient to ensure good bit cleaning the ROP is reduced either by:

- i. **bit balling** where the grooves between the teeth of the bit are clogged by formation cuttings (occurs mostly with soft formation bits), or
- ii. **bottom hole balling** where the hole gets clogged up with fine particles (occurs mostly with the grinding action of hard formation bits).

If this situation occurs no increase in ROP results from an increase in WOB unless the hydraulic horsepower (HHP) generated by the fluid flowing through the bit is improved (Figure 27). The HHP at the bit is given by:

$$\text{HHP}_b = \frac{P_b \times Q}{1714}$$

where:

P_b = pressure drop across the nozzles of the bit (psi)

Q = flow rate through the bit (gpm)

To increase HHP therefore requires an increase in P_b (smaller nozzles) or Q (faster pump speed or larger liners). This may mean a radical change to other drilling factors (e.g. annular velocity) which may not be beneficial. Hole cleaning may be improved by using extended nozzles to bring the fluid stream nearer to the bottom of the hole. Bit balling can be alleviated by using a fourth nozzle at the centre of the bit.

b. Type of formation

WOB is often limited in soft formations, where excessive weight will only bury the teeth into the rock and cause increased torque, with no increase in ROP.

c. Hole deviation

In some areas, WOB will produce bending in the drillstring, leading to a crooked hole. The drillstring should be properly stabilised to prevent this happening.

d. Bearing life

The greater the load on the bearings the shorter their operational life. Optimising ROP will depend on a compromise between WOB and bearing wear.

e. Tooth life

In hard formations, with high compressive strength, excessive WOB will cause the teeth to break. This will become evident when the bit is retrieved. Broken teeth is, for example, a clear sign that a bit with shorter, more closely packed teeth or inserts is required.

5.1.2. Rotary Speed

The ROP will also be affected by the rotary speed of the bit and an optimum speed must be determined. The RPM influences the ROP because the teeth must have time to penetrate and sweep the cuttings into the hole. Figure 28 shows how ROP varies with RPM for different formations. The non-linearity in hard formations is due to the time required to break down rocks of higher compressive strength. Experience plays a large part in selecting the correct rotary speed in any given situation.

The RPM applied to a bit will be a function of :

a. Type of bit

In general lower RPMs are used for insert bits than for milled tooth bits. This is to allow the inserts more time to penetrate the formation. The insert crushes a wedge of rock and then forms a crack which loosens the fragment of rock.

b. Type of formation

Harder formations are less easily penetrated and so require low RPM. A high RPM may cause damage to the bit or the drill string.

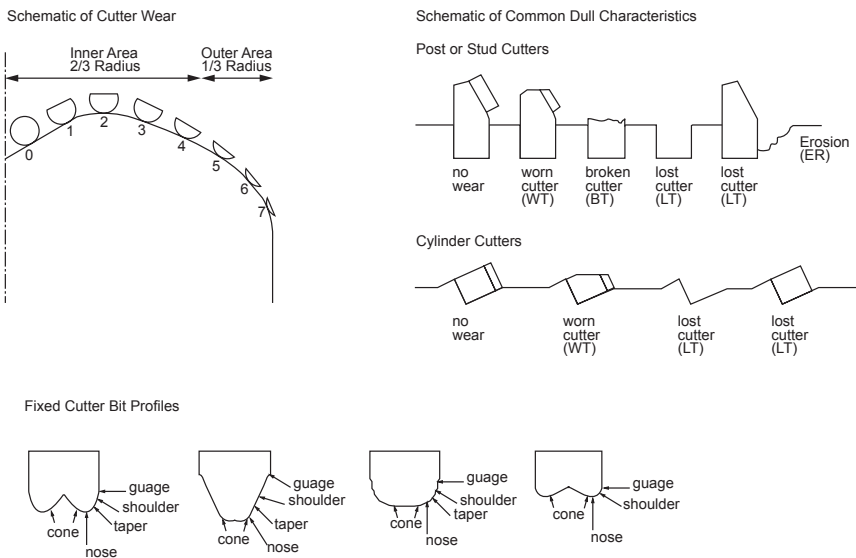

Figure 25 Location of dull characteristics

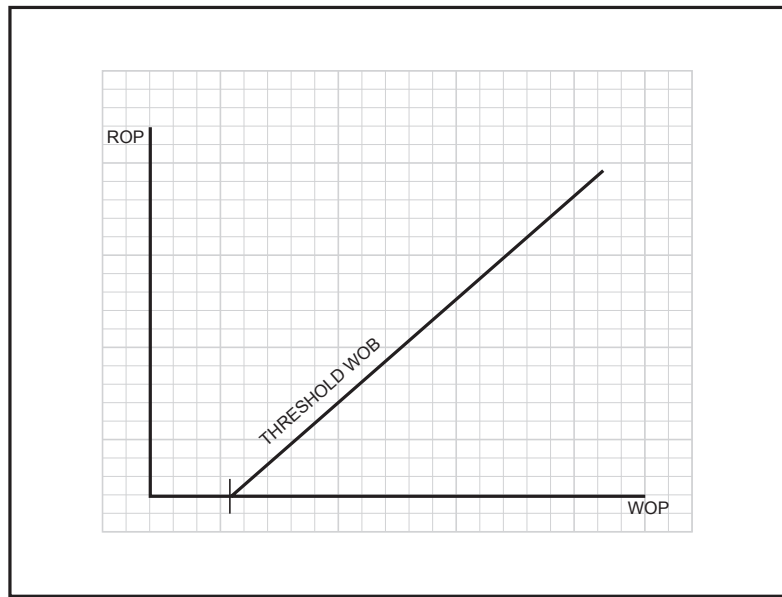

Figure 26 Penetration Rate vs. Weight on Bit

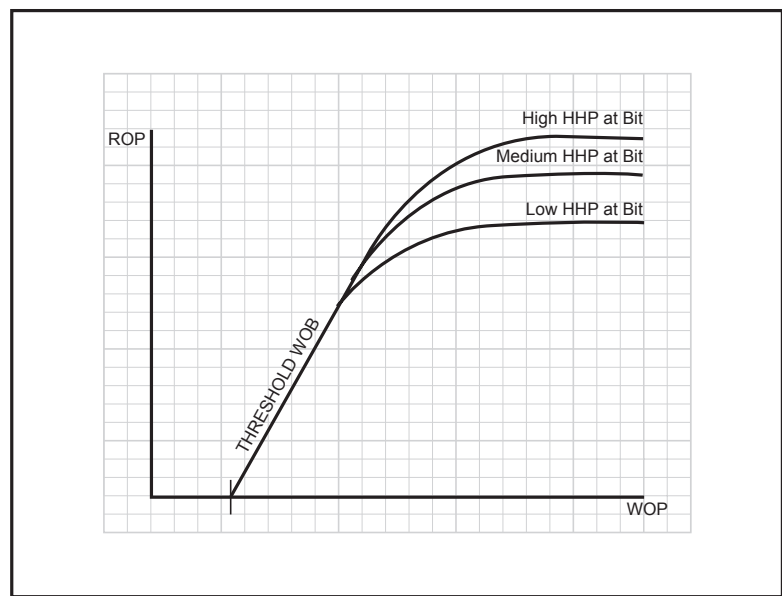

Figure 27 Penetration rate variation due to hole cleaning

5.1.3. Mud Properties

In order to prevent an influx of formation fluids into the wellbore the hydrostatic mud pressure must be slightly greater than the formation (pore) pressure. This overbalance, or positive pressure differential, forces the liquid portion of the mud (filtrate) into the formation, leaving the solids to form a filter cake on the wall of the borehole. In porous formations this filter cake prevents any further entry of mud into the formation. This overbalance and filter cake also exists at the bottom of the hole where it affects the removal of cuttings. When a tooth penetrates the surface



of the rock the compressive strength of the rock is exceeded and cracks develop, which loosen small fragments or chips from the formation (Figure 30). Between successive teeth the filter cake covers up the cracks and prevents mud pressure being exerted below the chip. The differential pressure on the chip tends to keep the chip against the formation. This is known as the **static chip hold down effect**, and leads to lower penetration rates. The amount of plastering which occurs depends on mud properties. To reduce the hold down effect:

- Reduce the positive differential pressure by lowering the mud weight (i.e. reduce the overbalance to the minimum acceptable level to prevent a kick).
- Reduce the solids content of the mud (both clay and drilled solids). Solids removal is essential to increase drilling efficiency.

In less porous formations the effect is not so significant since the filter cake is much thinner. However **dynamic chip hold down** may occur (Figure 30). This occurs because, when cracks form around the chip mud enters the cracks to equalise the pressure. In doing so, however, a pressure drop is created which tends to fix the chip against the bottom of the hole. The longer the tooth penetration, the greater the hold down pressure. Both static and dynamic hold down effects cause bit balling and bottom hole balling. This can be prevented by ensuring correct mud properties (e.g. mud weight and solids content).

5.2 PDC Bits

5.2.1 WOB/RPM

PDC bits tend to drill faster with low WOB and high RPM. They are also found to require higher torque than roller cone bits. The general recommendation is that the highest RPM that can be achieved should be used. Although the torque is fairly constant in shale sections the bit will tend to dig in and torque up in sandy sections. When drilling in these sandy sections, or when the bit drills into hard sections and penetration rate drops, the WOB should be reduced but should be maintained to produce a rotary torque at least equal to that of a roller cone bit. Too low a WOB will cause premature cutter wear, possible diamond chipping and a slow rate of penetration.

5.2.2 Mud Properties

The best ROP results have been achieved with oil based muds but a good deal of success has been achieved with water based muds. Reasons for the improved performance in oil based muds has been attributed to increased lubricity, decreased cutter wear temperature and preferential oil wetting of the bit body. The performance of PDC bits in respect to other mud properties is consistent with that found with roller cone bits i.e. increase in mud solids content or mudweight decreases ROP.

5.2.3 Hydraulic Efficiency

The effects of increased hydraulic horsepower at the bit are similar to their effect on roller cone bits. However manufacturers will often recommend a minimum flowrate in an attempt to ensure that the bit face is kept clean and cutter temperature is kept to a minimum. This requirement for flowrate may adversely affect optimisation of HHP.

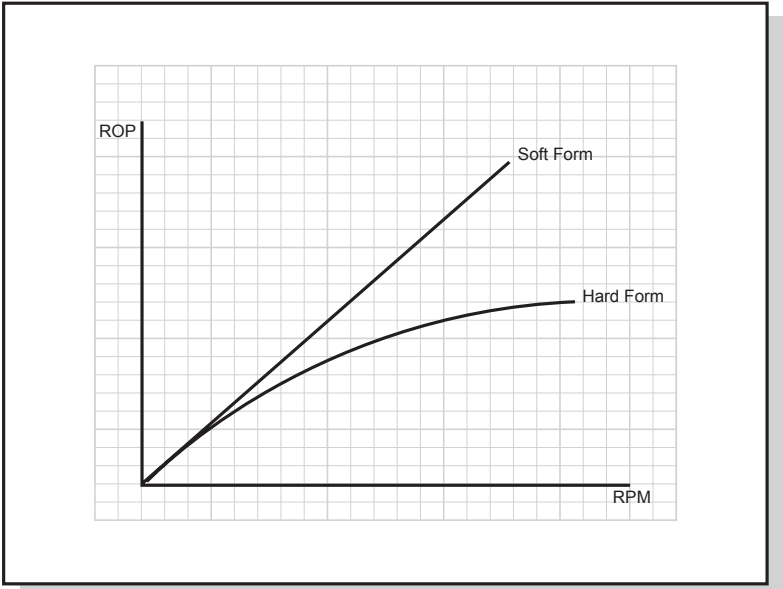

Figure 28 Penetration Rate vs. Rotary Speed

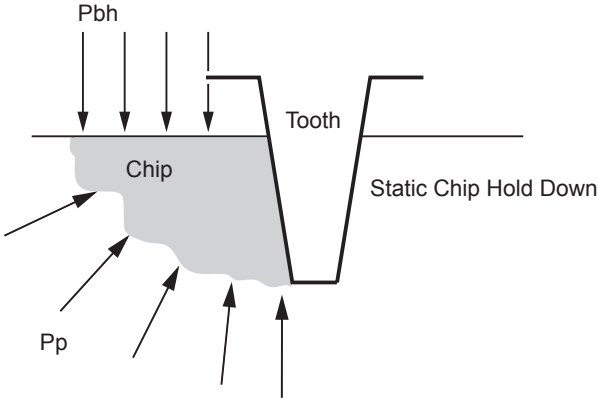

Figure 29 Static chip hold down effect

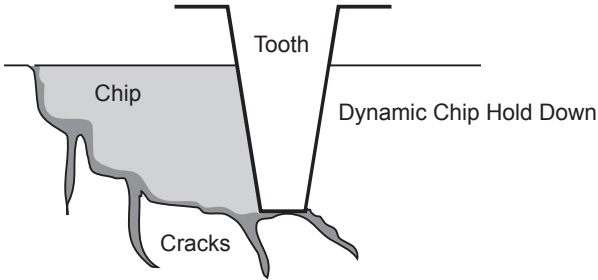

Figure 30 Dynamic hold down effect



Exercise 2 Cost per foot of a Bit Run

The following bit records are taken from the offset wells used in the design of the well shown in Appendix 1 of Chapter 1.

Assuming: that the geological conditions in this well are the same as those in the offset wells below; that the 12 1/4" section will be drilled from around 7000ft; an average trip time of 8 hrs; and a rig rate of £400/hr. select the best bit type to drill the 12 1/4" hole section.

WELL	BIT	COST (£)	DEPTH IN (FT.)	DEPTH OUT (FT.)	TIME ON BOTTOM (HR.)
I	A	350	7100	7306	14.9
II	B	1600	7250	7982	58.1
III	C	1600	7000	7983	96.3

Exercise 3 Cost Per Foot Whilst Drilling

Whilst drilling the 12 1/4" hole section of the new well the following drilling data is being recorded and provided to the company man. At what point in time would you have suggested that the bit be pulled and why? Assume an average trip time of 8 hrs, a rig rate of £400/hr and the bit type selected above had been run in hole.

TIME ON BOTTOM (HRS)	FOOTAGE DRILLED (FT)
1	34
2	62
3	86
4	110
5	126
6	154
7	180
8	210
9	216
10	226
11	234
12	240

Solutions to Exercises

Exercise 1 Selection of a Drillbit

The Type 1-2-6 bits available are :

SMITH TOOL	FDT
HUGHES	J2
REED	HP12
SECURITY	S33F

This is a milled tooth bit with sealed journal bearings. It is suitable for drilling soft formations with low compressive strength and high drillability. A bit of this type would tend to have long, widely spaced teeth, maximum offset and pin angle and, in this case, journal bearings.

Exercise 2 Cost per foot of a Bit Run

The process of selection of the best bit type from a number of offset wells requires a number of assumptions :

- The lithology encountered in the offset bit runs must be similar to that lithology expected in the proposed well.
- The depth of the offset bit runs are similar to that in the proposed well.
- The bit runs in the offset wells were run under optimum operating conditions (hydraulics, WOB, RPM etc.)

Having made these assumptions, the 'best bit' will be selected on the basis of footage drilled, ROP, and most importantly Cost per Foot of bit run.

The results of these numerical criteria are shown in Table Solution 2. The 'best' bit is considered to be bit B since this bit had the most economical bit run (£/ft).

It is worth noting that bit A would have been selected on the basis of ROP and bit C would have been selected on the basis of footage drilled.

Consideration should of course be given to the fact that although bit A drilled at a very fast rate it had only drilled 206 ft. and therefore the bit may have still been in very good condition. Bits B and C would have been worn to a greater extent than bit A and their ROP would consequently have decreased over the bit run.

RIG RATE £/HR.	4.00
TRIP TIME HRS	8

BIT	BIT COST £	FOOTAGE DRILLED FT.	TIME ON BOTTOM HRS.	ROP FT/HR.	COST/FT £/FT
A	350	206	14.90	13.83	46.17
B	1600	732	58.10	12.60	38.31
C	1600	983	96.30	10.21	44.07

Bit A is the cheapest and gives the highest penetration rate, but is the least economical in terms of £/FT..
 Bit B should be selected as the best bit for this hole section.

Table Solution 2 Bit Cost Evaluation

Exercise 3 Cost per Foot Whilst Drilling

The decision to pull a bit should be based on the performance of the bit over a period of time. Table Solution 3 and Figure Solution 3 shows that after 8 hours the cost per foot of the bit run has reached its minima and started to increase. Therefore consideration to pull the bit should be made at this point.

It should be noted that only ‘consideration’ is given to pulling the bit at this point. The engineer should first check with the mud loggers that the bit had not entered a new type of formation, since this may affect the performance of the bit. The engineer should also consider the proximity to the next casing or logging point and the consequent cost of running a new bit to drill what may be a relatively short section of hole. This must be weighed against the possibility of the bit breaking up and losing teeth or even a cone.

RIG RATE	400
BIT COST	1600
TRIP TIME	8

DRILLING TIME	FOOTAGE DRILLED	TOTAL COST OF RUN	COST PER FOOT
1	34	5200	152.94
2	62	5600	90.32
3	86	6000	69.77
4	110	6400	58.18
5	126	6800	53.97
6	154	7200	46.75
7	180	7600	42.22
8	210	8000	38.10
9	216	8400	38.89
10	226	8800	38.94
11	234	9200	39.32
12	240	9600	40.00

Notes :

$$1. \text{ TOTAL COST OF RUN} = \text{BIT COST} + \text{RIG RATE}(\text{TRIP TIME} + \text{TIME ON BOTTOM})$$

$$2. \text{ COST PER FOOT} = \frac{\text{TOTAL COST OF RUN}}{\text{FOOTAGE DRILLED}}$$

Table Solution 3 Bit Run Evaluation



BIT RUN COST

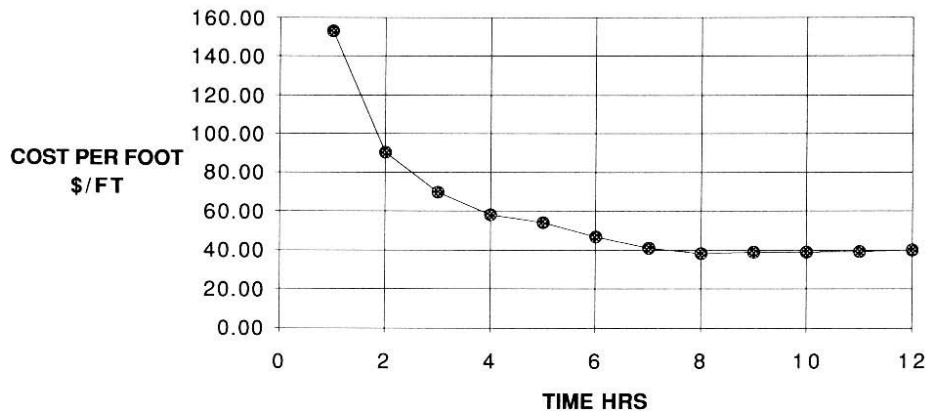
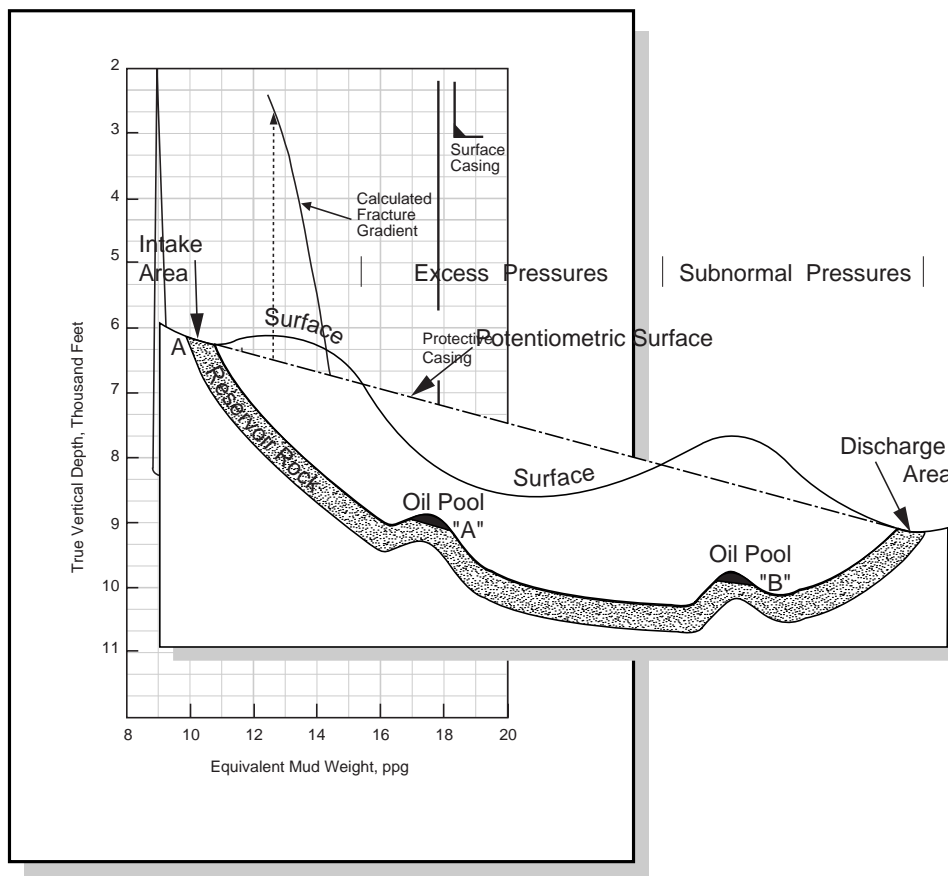

Figure Solution 3 Bit Run Evaluation

Formation Pressures 5



CONTENTS

1. INTRODUCTION
2. FORMATION PRESSURES
3. OVERBURDEN PRESSURES
4. ORIGIN OF ABNORMAL PRESSURES
 - 4.1 Origin of Subnormal Formation Pressures
 - 4.2 Origin of Overpressured Formations
5. DRILLING PROBLEMS ASSOCIATED WITH ABNORMAL FORMATION PRESSURES
6. TRANSITION ZONE
7. PREDICTION AND DETECTION OF ABNORMAL PRESSURES
 - 7.1 Predictive Techniques
 - 7.2 Detection Techniques
 - 7.2.1 Detection Based on Drilling Parameters
 - 7.2.2 Drilling Mud Parameters
 - 7.2.3 Drilled Cuttings
 - 7.3 Confirmation Techniques
8. FORMATION FRACTURE GRADIENT
 - 8.1 Mechanism of Formation Breakdown
 - 8.2 The Leak-Off Test, Limit Test and Formation Breakdown Test
 - 8.2.1 Leak Off Test Calculations
 - 8.2.2 The Equivalent Circulating Density (ECD) of a fluid
 - 8.2.3 MAASP
 - 8.3 Calculating the Fracture Pressure of a Formation
 - 8.4 Summary of Procedures





LEARNING OUTCOMES:

Having worked through this chapter the student will be able to:

General:

- Define the terms: Pressure Gradient; hydrostatic pressure; “Normal” Pressure; “Abnormal” Pressure; Overburden (geostatic) Pressure; Fracture pressure.
- Plot the above from a set of data from a well.
- Describe in general terms the origins and mechanisms which generate Overpressured and Underpressured reservoirs
- Describe in detail the mechanism of Undercompaction
- Describe the characteristics of the different types of seal above an abnormally pressured formation and their implications for overpressure detection.
- Describe the impact of Abnormally pressured formations on well design and drilling operations

Overpressure Prediction and Detection Techniques:

- List and describe the methods of predicting overpressures before drilling the well. Prioritise these techniques in order of reliability in a given environment.
- List and describe the techniques used for the detection of overpressures whilst drilling a well.
- Define the assumptions inherent in, and limitations of, the “d” exponent technique for overpressure detection.
- Calculate and plot the “d” exponent and modified “d” exponent and use these to determine the top of the overpressured zone.
- Calculate and plot shale density when used in the determination of overpressures.

Leak Off Test and Fracture Pressure:

- Describe the mechanisms of formation breakdown
- Define the terms: Limit test and Leak off test.
- Describe the procedure used when conducting a leak off test.
- Calculate the: maximum allowable mudweight (including ECD); and MAASP for the subsequent hole section after conducting a LOT.

1. INTRODUCTION

The magnitude of the pressure in the pores of a formation, known as the **formation pore pressure** (or simply **formation pressure**), is an important consideration in many aspects of well planning and operations. It will influence the casing design and mud weight selection and will increase the chances of stuck pipe and well control problems. It is particularly important to be able to predict and detect high pressure zones, where there is the risk of a blow-out.

In addition to predicting the pore pressure in a formation it is also very important to be able to predict the pressure at which the rocks will **fracture**. These fractures can result in losses of large volumes of drilling fluids and, in the case of an influx from a shallow formation, fluids flowing along the fractures all the way to surface, potentially causing a blowout.

When the pore pressure and fracture pressure for all of the formations to be penetrated have been predicted the well will be designed, and the operation conducted, such that the pressures in the borehole neither exceed the fracture pressure, nor fall below the pore pressure in the formations being drilled.

2. FORMATION PORE PRESSURES

During a period of erosion and sedimentation, grains of sediment are continuously building up on top of each other, generally in a water filled environment. As the thickness of the layer of sediment increases, the grains of the sediment are packed closer together, and some of the water is expelled from the pore spaces. However, if the pore throats through the sediment are interconnecting all the way to surface the pressure of the fluid at any depth in the sediment will be same as that which would be found in a simple colom of fluid. The pressure in the fluid in the pores of the sediment will only be dependent on the density of the fluid in the pore space and the depth of the pressure measurement (equal to the height of the colom of liquid). it will be independent of the pore size or pore throat geometry. The pressure of the fluid in the pore space (the **pore pressure**) can be measured and plotted against depth as shown in Figure 1. This type of diagram is known as a P-Z diagram

The pressure in the formations to be drilled is often expressed in terms of a pressure gradient. This gradient is derived from a line passing through a particular formation pore pressure and a datum point at surface and is known as the **pore pressure gradient**. The reasons for this will become apparent subsequently. The datum which is generally used during drilling operations is the drillfloor elevation but a more general datum level, used almost universally, is Mean Sea Level, MSL. When the pore throats through the sediment are interconnecting, the pressure of the fluid at any depth in the sediment will be same as that which would be found in a simple colom of fluid and therefore the pore pressure gradient is a straight line as shown in Figure 1. The gradient of the line is a representation of the density of the fluid. Hence the density of the fluid in the pore space is often expressed in units of psi/ft.

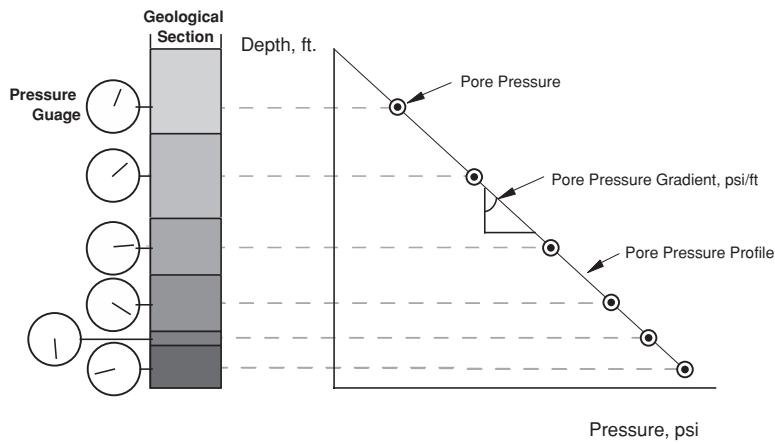

Figure 1 P-Z Diagram representing pore pressures

This is a very convenient unit of representation since the pore pressure for any given formation can easily be deduced from the pore pressure gradient if the vertical depth of the formation is known. Representing the pore pressures in the formations in terms of pore pressure gradients is also convenient when computing the density of the drilling fluid that will be required to drill through the formations in question. If the density of the drilling fluid in the wellbore is also expressed in units of psi/ft then the pressure at all points in the wellbore can be compared with the pore pressures to ensure that the pressure in the wellbore exceeds the pore pressure. The differential between the mud pressure and the pore pressure at any given depth is known as the **overbalance pressure** at that depth (Figure 2). If the mud pressure is less than the pore pressure then the differential is known as the **underbalance pressure**. It will be seen below that the fracture pressure gradient of the formations is also expressed in units of psi/ft.

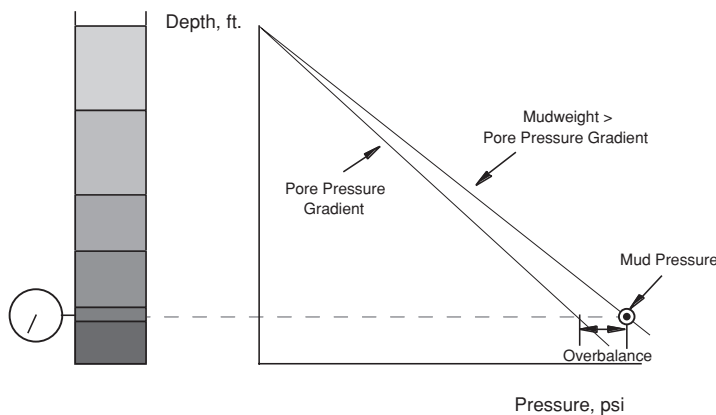

Figure 2 Mud density compared to pore pressure gradient

Most of the fluids found in the pore space of sedimentary formations contain a proportion of salt and are known as brines. The dissolved salt content may vary from 0 to over 200,000 ppm. Correspondingly, the pore pressure gradient ranges from 0.433 psi/ft (pure water) to about 0.50 psi/ft. In most geographical areas the pore

pressure gradient is approximately 0.465 psi/ft (assumes 80,000 ppm salt content) and this pressure gradient has been defined as the **normal pressure gradient**. Any formation pressure above or below the points defined by this gradient are called **abnormal pressures** (Figure 3). The mechanisms by which these abnormal pressures can be generated will be discussed below. When the pore fluids are normally pressured the formation pore pressure is also said to be **hydrostatic**.

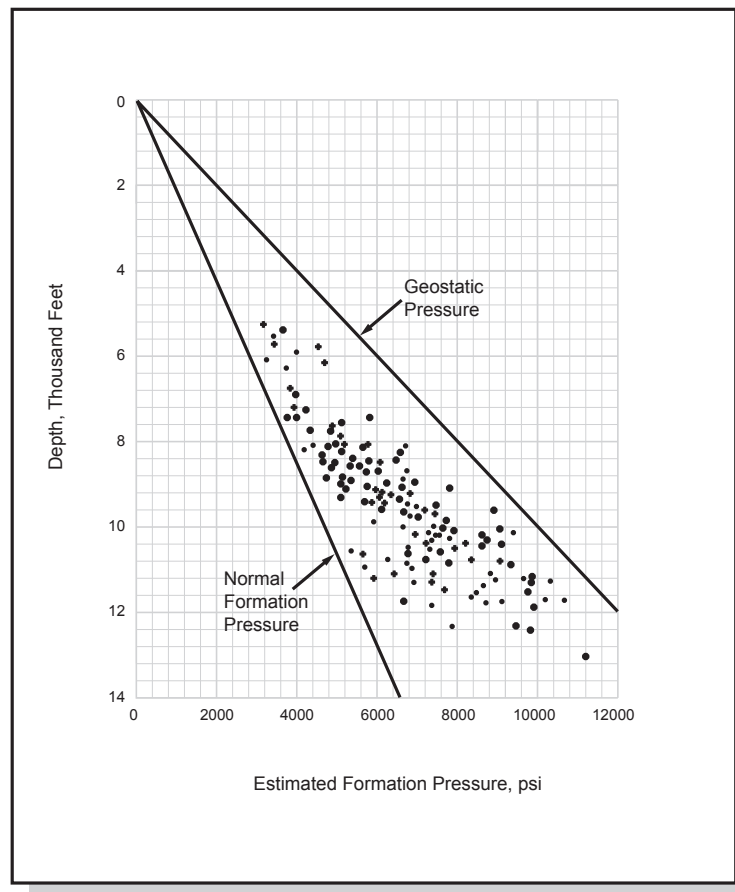

Figure 3 Abnormal formation pressures plotted against depth for 100 US wells

3. OVERBURDEN PRESSURES

The pressures discussed above relate exclusively to the pressure in the pore space of the formations. It is however also important to be able to quantify the vertical stress at any depth since this pressure will have a significant impact on the pressure at which the borehole will fracture when exposed to high pressures. The vertical pressure at any point in the earth is known as the **overburden pressure or geostatic pressure**. The overburden gradient is derived from a cross plot of overburden pressure versus depth (Figure 4). The overburden pressure at any point is a function of the mass of rock and fluid above the point of interest. In order to calculate the overburden pressure at any point, the average density of the material (rock and fluids) above the point of interest must be determined. The average density of the rock and fluid in the pore space is known as the bulk density of the rock :

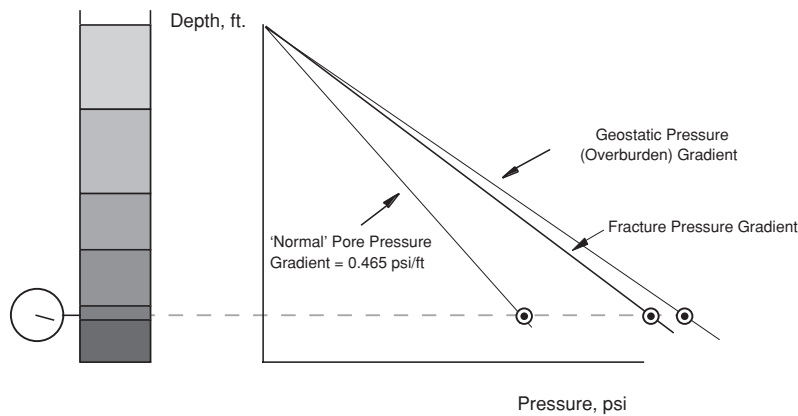

Figure 4 Pore Pressure, Fracture Pressure and Overburden Pressures and Gradients for a Particular Formation

$$\rho_b = \rho_f \times \phi + \rho_m (1 - \phi)$$

or

$$\rho_b = \rho_m - (\rho_m - \rho_f) \phi$$

where,

- ρ_b = bulk density of porous sediment
- ρ_m = density of rock matrix
- ρ_f = density of fluid in pore space
- ϕ = porosity

Since the matrix material (rock type), porosity, and fluid content vary with depth, the bulk density will also vary with depth. The overburden pressure at any point is therefore the integral of the bulk density from surface down to the point of interest.

The specific gravity of the rock matrix may vary from 2.1 (sandstone) to 2.4 (limestone). Therefore, using an average of 2.3 and converting to units of psi/ft, it can be seen that the overburden pressure gradient exerted by a typical rock, with zero porosity would be :

$$2.3 \times 0.433 \text{ psi/ft} = 0.9959 \text{ psi/ft}$$

This figure is normally rounded up to 1 psi/ft and is commonly quoted as the maximum possible overburden pressure gradient, from which the maximum overburden pressure, at any depth, can be calculated. It is unlikely that the pore pressure could exceed the overburden pressure. However, it should be remembered that the overburden pressure may vary with depth, due to compaction and changing lithology, and so the gradient cannot be assumed to be constant.

4. ABNORMAL PRESSURES

Pore pressures which are found to lie above or below the “normal” pore pressure gradient line are called abnormal pore pressures (Figure 5 and 6). These formation pressures may be either Subnormal (i.e. less than 0.465 psi/ft) or Overpressured (i.e. greater than 0.465 psi/ft). The mechanisms which generate these abnormal pore pressures can be quite complex and vary from region to region. However, the most common mechanism for generating overpressures is called **Undercompaction** and can be best described by the **undercompaction model**.

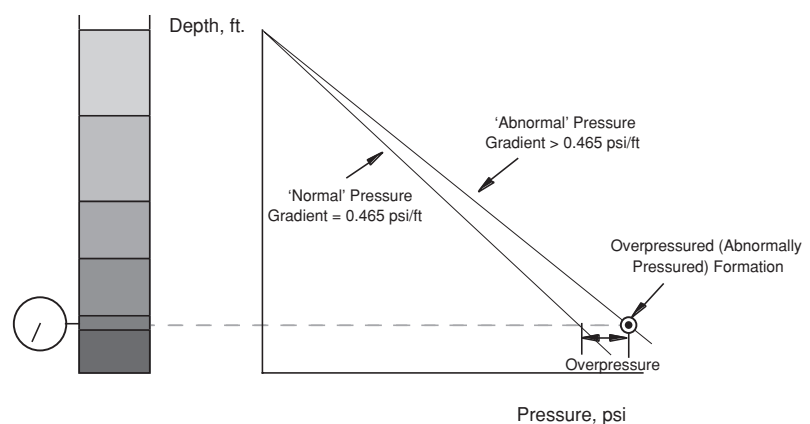

Figure 5 Overpressured Formation

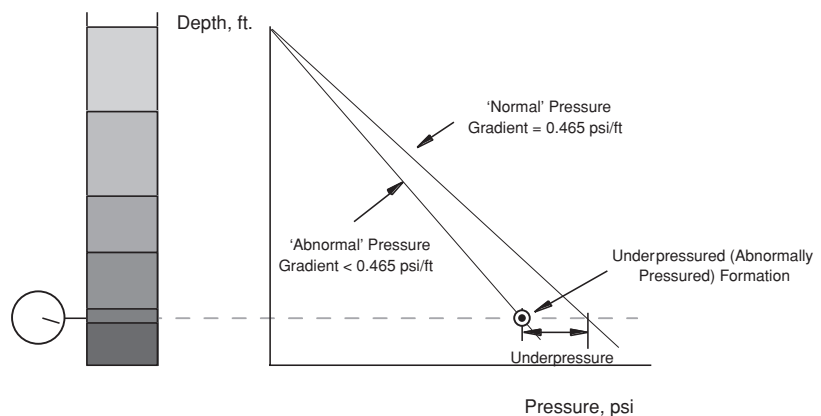

Figure 6 Underpressured (Subnormal pressured) formation

The compaction process can be described by a simplified model (Figure 7) consisting of a vessel containing a fluid (representing the pore fluid) and a spring (representing the rock matrix). The overburden stress can be simulated by a piston being forced down on the vessel. The overburden (S) is supported by the stress in the spring (σ) and the fluid pressure (p). Thus:

$$S = \sigma + p$$

If the overburden is increased (e.g. due to more sediments being laid down) the extra load must be borne by the matrix and the pore fluid. If the fluid is prevented from leaving the pore space (drainage path closed) the fluid pressure must increase above the hydrostatic value. Such a formation can be described as overpressured (i.e. part of the overburden stress is being supported by the fluid in the pore space and not the matrix). Since the water is effectively incompressible the overburden is almost totally supported by the pore fluid and the grain to grain contact stress is not increased. In a formation where the fluids are free to move (drainage path open), the increased load must be taken by the matrix, while the fluid pressure remains constant. Under such circumstances the pore pressure can be described as Normal, and is proportional to depth and fluid density.

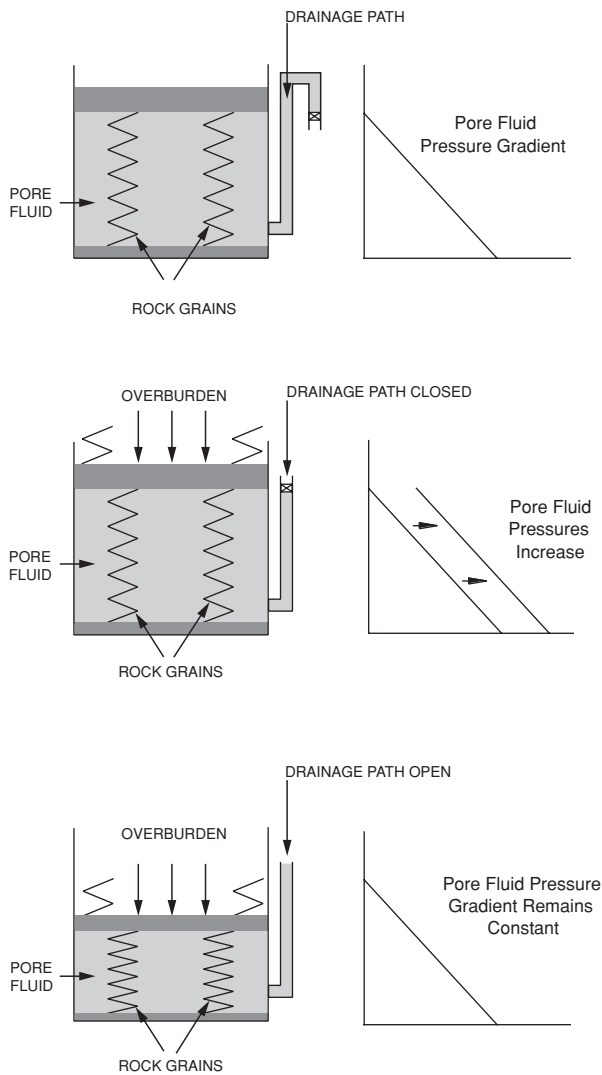

Figure 7 Overpressure Generation Mechanism

In order for abnormal pressures to exist the pressure in the pores of a rock must be sealed in place i.e. the pore are not interconnecting. The seal prevents equalisation of the pressures which occur within the geological sequence. The seal is formed by a permeability barrier resulting from physical or chemical action. A **physical seal** may be formed by gravity faulting during deposition or the deposition of a fine grained material. The **chemical seal** may be due to calcium carbonate being deposited, thus restricting permeability. Another example might be chemical diagenesis during compaction of organic material. Both physical and chemical action may occur simultaneously to form a seal (e.g. gypsum-evaporite action).

4.1 Origin of Subnormal Formation Pressures

The major mechanisms by which subnormal (less than hydrostatic) pressures occur may be summarised as follows:

(a) Thermal Expansion

As sediments and pore fluids are buried the temperature rises. If the fluid is allowed to expand the density will decrease, and the pressure will reduce.

(b) Formation Foreshortening

During a compression process there is some bending of strata (Figure 8). The upper beds can bend upwards, while the lower beds can bend downwards. The intermediate beds must expand to fill the void and so create a subnormally pressured zone. This is thought to apply to some subnormal zones in Indonesia and the US. Notice that this may also cause overpressures in the top and bottom beds.

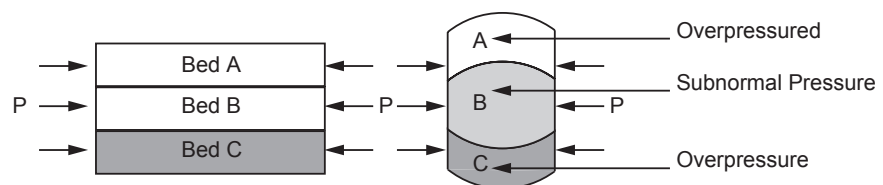

Figure 8 Foreshortening of intermediate beds. shortening of bed B due to the warping of beds A and C causes unique pressure problems

(c) Depletion

When hydrocarbons or water are produced from a competent formation in which no subsidence occurs a subnormally pressured zone may result. This will be important when drilling development wells through a reservoir which has already been producing for some time. Some pressure gradients in Texas aquifers have been as low as 0.36 psi/ft.

(d) Precipitation

In arid areas (e.g. Middle East) the water table may be located hundreds of feet below surface, thereby reducing the hydrostatic pressures.

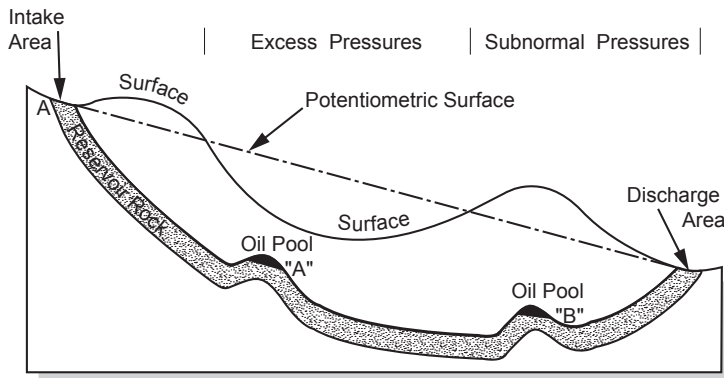

Figure 9 The effect of the potentiometric surface in relationship to the ground surface causing overpressures and subnormal pressures

(e) Potentiometric Surface

This mechanism refers to the structural relief of a formation and can result in both subnormal and overpressured zones. The potentiometric surface is defined by the height to which confined water will rise in wells drilled into the same aquifer. The potentiometric surface can therefore be thousands of feet above or below ground level (Figure 9).

(f) Epeirogenic Movements

A change in elevation can cause abnormal pressures in formations open to the surface laterally, but otherwise sealed. If the outcrop is raised this will cause overpressures, if lowered it will cause subnormal pressures (Figure 10).

Pressure changes are seldom caused by changes in elevation alone since associated erosion and deposition are also significant. Loss or gain of water saturated sediments is also important.

The level of underpressuring is usually so slight it is not of any practical concern. By far the largest number of abnormal pressures reported have been overpressures, and not subnormal pressures.

4.2 Origin of Overpressured Formations

These are formations whose pore pressure is greater than that corresponding to the normal gradient of 0.465 psi/ft. As shown in Figure 11 these pressures can be plotted between the hydrostatic gradient and the overburden gradient (1 psi/ft). The following examples of overpressures have been reported:

Gulf Coast	0.8 - 0.9	psi/ft
Iran	0.71 - 0.98	"
North Sea	0.5 - 0.9	"
Carpathian Basin	0.8 - 1.1	"

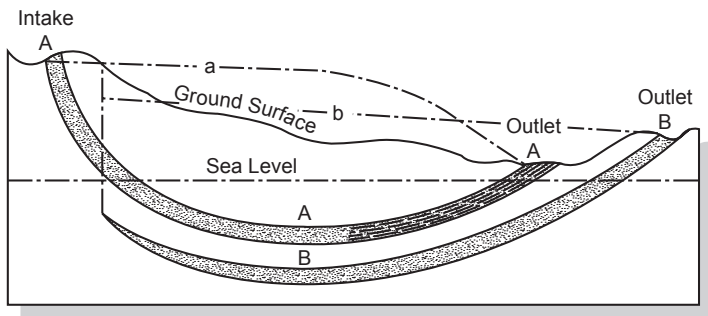

Figure 10 Section through a sedimentary basin showing two potentiometric surfaces relating to the two reservoirs A and B

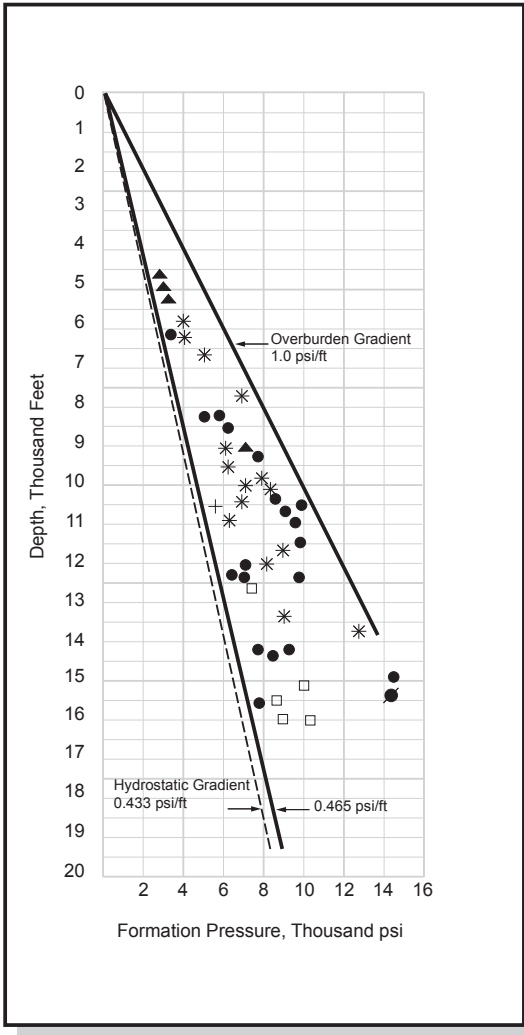

Figure 11 Overpressures observed in European Wells

From the above list it can be seen that overpressures occur worldwide. Some results from European fields are given in Figure 11. There are numerous mechanisms which cause such pressures to develop. Some, such as potentiometric surface and formation foreshortening have already been mentioned under subnormal pressures since both effects can occur as a result of these mechanisms. The other major mechanisms are summarised below:

(a) Incomplete Sediment Compaction

Incomplete sediment compaction or undercompaction is the most common mechanism causing overpressures. In the rapid burial of low permeability clays or shales there is little time for fluids to escape. Under normal conditions the initial high porosity (+/- 50%) is decreased as the water is expelled through permeable sand structures or by slow percolation through the clay/shale itself. If however the burial is rapid and the sand is enclosed by impermeable barriers (Figure 12), there is no time for this process to take place, and the trapped fluid will help to support the overburden.

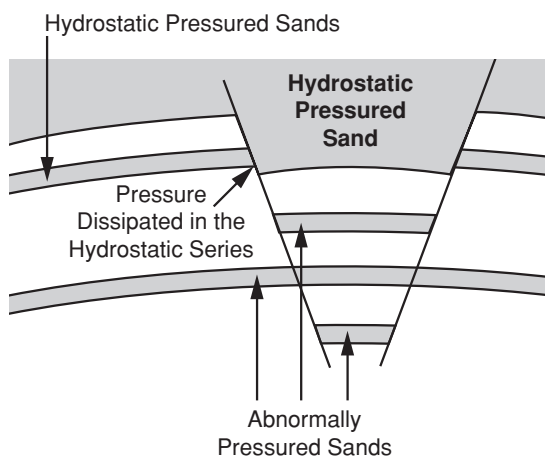

Figure 12 Barriers to flow and generation of overpressured sand

(b) Faulting

Faults may redistribute sediments, and place permeable zones opposite impermeable zones, thus creating barriers to fluid movement. This may prevent water being expelled from a shale, which will cause high porosity and pressure within that shale under compaction.

(c) Phase Changes during Compaction

Minerals may change phase under increasing pressure, e.g. gypsum converts to anhydrite plus free water. It has been estimated that a phase change in gypsum will result in the release of water. The volume of water released is approximately 40% of the volume of the gypsum. If the water cannot escape then overpressures will be generated. Conversely, when anhydrite is hydrated at depth it will yield gypsum and result in a 40% increase in rock volume. The transformation of montmorillonite to illite also releases large amounts of water.

(d) Massive Rock Salt Deposition

Deposition of salt can occur over wide areas. Since salt is impermeable to fluids the underlying formations become overpressured. Abnormal pressures are frequently found in zones directly below a salt layer.

(e) Salt Diaperism

This is the upwards movement of a low density salt dome due to buoyancy which disturbs the normal layering of sediments and produces pressure anomalies. The salt may also act as an impermeable seal to lateral dewatering of clays.

(f) Tectonic Compression

The lateral compression of sediments may result either in uplifting weathered sediments or fracturing/faulting of stronger sediments. Thus formations normally compacted at depth can be raised to a higher level. If the original pressure is maintained the uplifted formation is now overpressured.

(g) Repressuring from Deeper Levels

This is caused by the migration of fluid from a high to a low pressure zone at shallower depth. This may be due to faulting or from a poor casing/cement job. The unexpectedly high pressure could cause a kick, since no lithology change would be apparent. High pressures can occur in shallow sands if they are charged by gas from lower formations.

(h) Generation of Hydrocarbons

Shales which are deposited with a large content of organic material will produce gas as the organic material degrades under compaction. If it is not allowed to escape the gas will cause overpressures to develop. The organic by-products will also form salts which will be precipitated in the pore space, thus helping to reduce porosity and create a seal.

5. DRILLING PROBLEMS ASSOCIATED WITH ABNORMAL FORMATION PRESSURES

When drilling through a formation sufficient hydrostatic mud pressure must be maintained to

- Prevent the borehole collapsing and
- Prevent the influx of formation fluids.

To meet these 2 requirements the mud pressure is kept slightly higher than formation pressure. This is known as overbalance. If, however, the overbalance is too great this may lead to:

- Reduced penetration rates (due to chip hold down effect)
- Breakdown of formation (exceeding the fracture gradient) and subsequent lost circulation (flow of mud into formation)
- Excessive differential pressure causing stuck pipe.



The formation pressure will also influence the design of casing strings. If there is a zone of high pressure above a low pressure zone the same mud weight cannot be used to drill through both formations otherwise the lower zone may be fractured. The upper zone must be “cased off”, allowing the mud weight to be reduced for drilling the lower zone. A common problem is where the surface casing is set too high, so that when an

overpressured zone is encountered and an influx is experienced, the influx cannot be circulated out with heavier mud without breaking down the upper zone. Each casing string should be set to the maximum depth allowed by the fracture gradient of the exposed formations. If this is not done an extra string of protective casing may be required. This will not only prove expensive, but will also reduce the wellbore diameter. This may have implications when the well is to be completed since the production tubing size may have to be restricted.

Having considered some of these problems it should be clear that any abnormally pressured zone must be identified and the drilling programme designed to accommodate it.

6. TRANSITION ZONE

It is clear from the descriptions of the ways in which overpressures are generated above that the pore pressure profile in a region where overpressures exist will look something like the P-Z diagram shown in Figure 13. It can be seen that the pore pressures in the shallower formations are “normal”. That is that they correspond to a hydrostatic fluid gradient. There is then an increase in pressure with depth until the “overpressured” formation is entered. The zone between the normally pressured zone and the overpressured zone is known as the **transition zone**.

The pressures in both the transition and overpressured zone is quite clearly above the hydrostatic pressure gradient line. The transition zone is therefore the seal or **caprock** on the overpressured formation. It is important to note that the transition zone shown in Figure 13 is representative of a thick shale sequence. This shale will have some low level of porosity and the fluids in the pore space can therefore be overpressured. However, the permeability of the shale is so low that the fluid in the shale and in the overpressured zone below the shale cannot flow through the shale and is therefore effectively trapped. Hence the caprock of a reservoir is not necessarily a totally impermeable formation but is generally simply a very low permeability formation.

If the seal is a thick shale, the increase in pressure will be gradual and there are techniques for detecting the increasing pore pressure. However, if the seal is a hard, crystalline rock (with no permeability at all) the transition will be abrupt and it will not be possible to detect the increase in pore pressure across the seal.

When drilling in a region which is known to have overpressured zones the drilling crew will therefore be monitoring various drilling parameters, the mud, and the drilled cuttings in an attempt to detect this increase in pressure in the transition

zone. It is the transition zone which provides the opportunity for the drilling crew to realise that they are entering an overpressured zone. The key to understanding this operation is to understand that although the pressure in the transition zone may be quite high, the fluid in the pore space cannot flow into the wellbore. When however the drillbit enters the high permeability, overpressured zone below the transition zone the fluids will flow into the wellbore. In some areas operating companies have adopted the policy of deliberately reducing the overbalance so as to detect the transition zone more easily - even if this means taking a kick.

It should be noted that the overpressures in a transition zone cannot result in an influx of fluid into the well since the seal has, by definition, an extremely low permeability. The overpressures must therefore be detected in some other way.

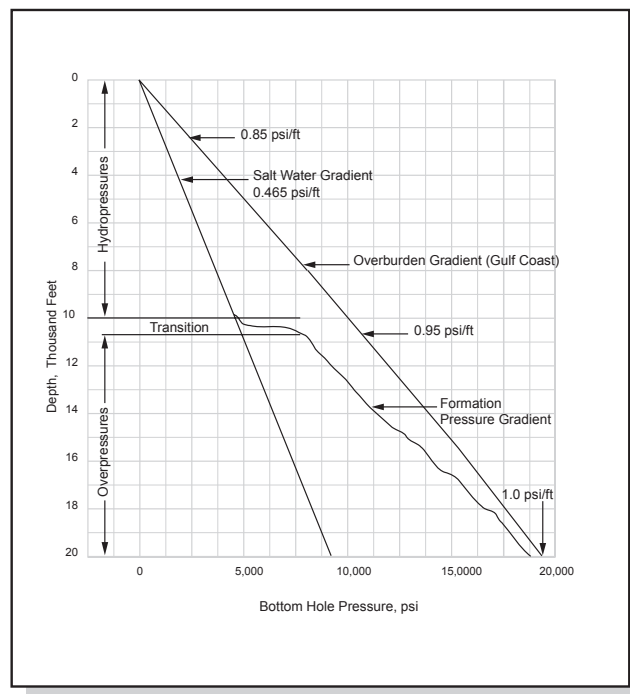

Figure 13 Transition from normal pressures to overpressures



Exercise 1 Pore Pressure Profiles

a. The following pore pressure information has been supplied for the well you are about to drill. Plot the following pore pressure/depth information on a P-Z diagram :

DEPTH BELOW DRILLFLOOR (ft)	PRESSURE (psi)
0	0
1000	465
5000	2325
8000	3720
8500	6800
9000	6850
9500	6900

b. Calculate the pore pressure gradients in the formations from surface; to 8000ft; to 8500ft; and to 9500ft. Plot the overburden gradient (1 psi/ft) on the above plot. Determine the mudweight required to drill the hole section: down to 8000ft; down to 8500ft; and down to 9500ft.

Assume that 200 psi overbalance on the formation pore pressure is required.

c. If the mudweight used to drill down to 8000ft were used to drill into the formation pressures at 8500ft what would be the over/underbalance on the formation pore pressure at this depth?

d. Assuming that the correct mudweight is used for drilling at 8500ft but that the fluid level in the annulus dropped to 500 ft below drillfloor, due to inadequate hole fill up during tripping. What would be the effect on bottom hole pressure at 8500ft ?

e. What type of fluid is contained in the formations below 8500ft.

7. PREDICTION AND DETECTION OF ABNORMAL PRESSURES

The techniques which are used to predict (before drilling), detect (whilst drilling) and confirm (after drilling) overpressures are summarised in Table 1.

7.1 Predictive Techniques

The predictive techniques are based on measurements that can be made at surface, such as geophysical measurements, or by analysing data from wells that have been drilled in nearby locations (offset wells). Geophysical measurements are generally used to identify geological conditions which might indicate the potential for overpressures such as salt domes which may have associated overpressured zones. Seismic data has been used successfully to identify transition zones and fluid content such as the presence of gas. Offset well histories may contain information on mud weights used, problems with stuck pipe, lost circulation or kicks. Any wireline logs or mudlogging information is also valuable when attempting to predict overpressures.

7.2 Detection Techniques

Detection techniques are used whilst drilling the well. They are basically used to detect an increase in pressure in the transition zone. They are based on three forms of data:

- Drilling parameters - observing drilling parameters (e.g.ROP) and applying empirical equations to produce a term which is dependent on pore pressure.
- Drilling mud - monitoring the effect of an overpressured zone on the mud (e.g. in temperature, influx of oil or gas).
- Drilled cuttings - examining cuttings, trying to identify cuttings from the sealing zone.

Source of Data	Parameters	Time of Recording
Geophysical methods	Formation velocity (Seismic) Gravity Magnetics Electrical prospecting Methods	Prior to spudding well
Drilling Mud	Gas Content Flowline Mudweight "kicks" Flowline Temperature Chlorine variation Drillpipe pressure Pit volume Flowrate Hole Fillup	While drilling
Drilling parameters	Drilling rate d.d.c exponent Drilling rate equations Torque Drag Drilling	While drilling Delayed by the time required for mud return
Drill Cuttings	Shale cuttings Bulk density Shale factor Electrical resistivity Volume Shape and Size Novel geochemical, physical techniques	While drilling Delayed by time required for sample return
Well Logging	Electrical survey Resistivity Conductivity Shale formation factor Salinity variations Interval transit time bulk density hydrogen index Thermal neutron cam capture cross section Nuclear Magnetic Resonance Downhole gravity data	After drilling
Direct Pressure Measuring Devices	Pressure bombs Drill stem test Wire line formation test	When well is tested or completed

Table 1 Methods for predicting and detecting abnormal pressures



7.2.1 Detection Based on Drilling Parameters

The theory behind using drilling parameters to detect overpressured zones is based on the fact that:

- Compaction of formations increases with depth. ROP will therefore, all other things being constant, decrease with depth
- In the transition zone the rock will be more porous (less compacted) than that in a normally compacted formation and this will result in an increase in ROP. Also, as drilling proceeds, the differential pressure between the mud hydrostatic and formation pore pressure in the transition zone will reduce, resulting in a much greater ROP.

The use of the ROP to detect transition and therefore overpressured zones is a simple concept, but difficult to apply in practice. This is due to the fact that many factors affect the ROP, apart from formation pressure (e.g. rotary speed and WOB). Since these other effects cannot be held constant, they must be considered so that a direct relationship between ROP and formation pressure can be established. This is achieved by applying empirical equations to produce a “normalised” ROP, which can then be used as a detection tool.

(a) The “d” exponent

The “d” exponent technique for detection of overpressures is based on a normalised drilling rate equation developed by Bingham (1964). Bingham proposed the following generalised drilling rate equation:

$$R = aN^e \left(\frac{W}{B}\right)^d$$

where,

- R = penetration rate (ft/hr)
- N = rotary speed (rpm)
- W = WOB (lb)
- B = bit diameter (in.)
- a = matrix strength constant
- d = formation drillability
- e = rotary speed exponent

Jordan and Shirley (1966) re-organised this equation to be explicit in “d”. This equation was then simplified by assuming that the rock which was being drilled did not change ($a = 1$) and that the rotary speed exponent (e) was equal to one. The rotary speed exponent has been found experimentally to be very close to one. This removed the variables which were dependent on lithology and rotary speed. This means however that the resulting equation can only be applied to one type of lithology and theoretically at a single rotary speed. The latter is not too restrictive since the value of e is generally close to 1(one). On the basis of these assumptions and accepting these limitations the following equation was produced:

$$d = \frac{\log\left(\frac{R}{60N}\right)}{\log\left(\frac{12W}{10^6 B}\right)}$$

This equation is known as the “**d-exponent**” equation. Since the values of R, N, W and B are either known or can be measured at surface the value of the d-exponent can be determined and plotted against depth for the entire well. Values of “d” can be found by using the nomogram in Figure 14. Notice that the value of the d-exponent varies inversely with the drilling rate. As the bit drills into an overpressured zone the compaction and differential pressure will decrease, the ROP will increase, and so the d-exponent should decrease. An overpressured zone will therefore be identified by plotting d-exponent against depth and seeing where the d-exponent reduces (Figure 15).

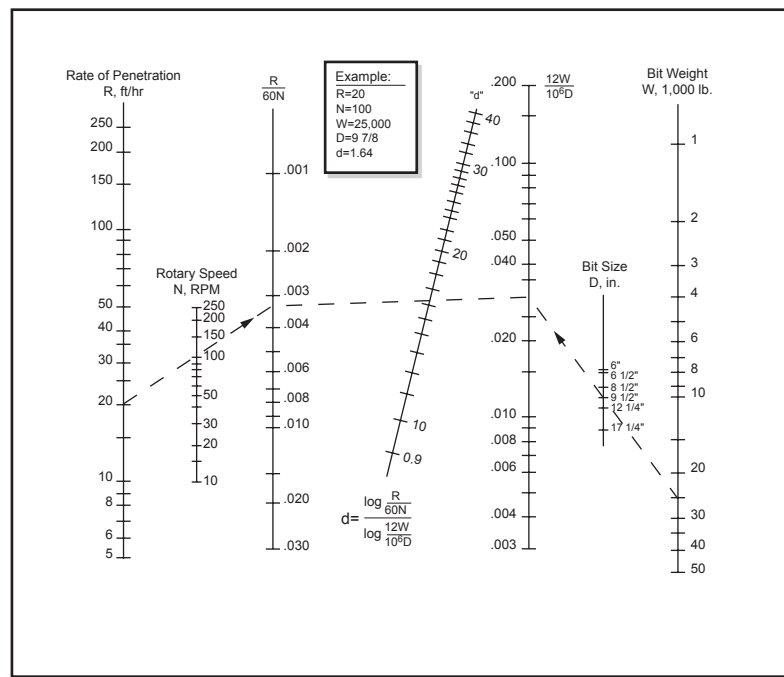

Figure 14 Nomogram for calculating "d" exponent

It should be realised that this equation takes into account variations in the major drilling parameters, but for accurate results the following conditions should be maintained:

- No abrupt changes in WOB or RPM should occur, i.e. keep WOB and RPM as constant as possible.
- To reduce the dependence on lithology the equation should be applied over small depth increments only (plot every 10').
- A good thick shale is required to establish a reliable “trend” line.

It can be seen that the d-exponent equation takes no account of mudweight. Since mudweight determines the pressure on the bottom of the hole the greater the mudweight the greater the chip hold-down effect and therefore the lower the ROP. A modified d-exponent (d_c) which accounts for variations in mudweight has therefore been derived:

$$d_c = d \left(\frac{MW_n}{MW_a} \right)$$

where,

- MW_n = “normal” mud weight
- MW_a = actual mud weight

The d_c exponent trend gives a better definition of the transition (Figure 15).

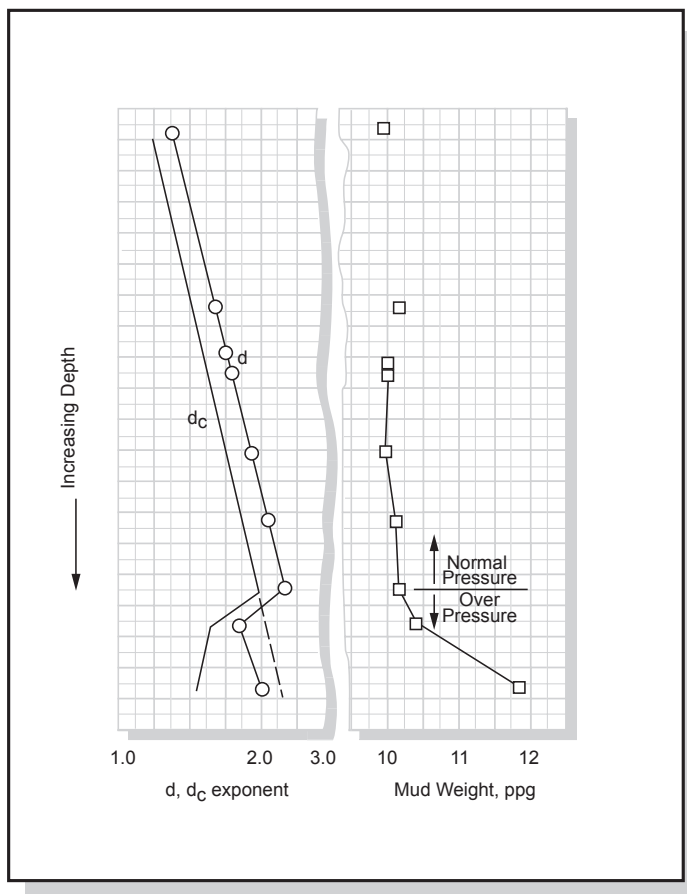

Figure 15 Comparison of d and d_c drilling exponents used in geopressure detection

The d exponent is generally used to simply identify the top of the overpressured zone. The value of the formation pressure can however be derived from the modified d-exponent, using a method proposed by **Eaton** (1976):

$$\frac{P}{D} = \frac{S}{D} \left[\frac{S}{D} - \left(\frac{P}{D} \right)_n \right] \left[\frac{d_{co}}{d_{cn}} \right]^{1.2}$$

where,

$\frac{P}{D}$ = fluid pressure gradient (psi/ft)

$\frac{S}{D}$

= overburden gradient (psi/ft)

$\left(\frac{P}{D} \right)_n$

= observed dc at given depth

d_{cn} = dc from normal trend (i.e. extrapolated) at given depth

Eaton claims the relationship is applicable worldwide and is accurate to 0.5 ppg.

(b) Other Drilling Parameters

Torque can be useful for identifying overpressured zones. An increase in torque may occur if the decrease in overbalance results in the physical breakdown of the borehole wall and more material, than the drilled cuttings is accumulating in the annulus. There is also the suggestion that the walls of the borehole may squeeze into the open hole as a result of the reduction in differential pressure. Drag may also increase as a result of these effects, although increases in drag are more difficult to identify.



Exercise 2 'd' and 'dc' Exponent

- Whilst drilling the 12 1/4" hole section of a well the mudloggers were recording the data as shown in the table below. Plot the d and d_c exponent and determine whether there are any indications of an overpressured zone.
- If an overpressured zone exists, what is the depth of the top of the transition zone.
- Use the Eaton equation to estimate the formation pressure at 8600 ft.

Assume a normal formation pressure of 0.465 psi/ft. an overburden gradient of 1.0 psi/ft and a normal mud weight for this area of 9.5 ppg.

DEPTH (ft.)	ROP (ft./hr)	RPM	WOB (,000 lbs)	MUD WEIGHT PPG
7500	125	120	38	9.5
7600	103	120	38	9.5
7700	77	110	38	9.5
7800	66	110	38	9.6
7900	45	110	35	9.6
8000	37	110	37	9.8
8100	40	110	35	9.8
8200	42	110	33	9.9
8300	41	100	33	10.0
8400	44	100	38	10.25
8500	34	100	38	10.25
8600	33	100	40	11
8700	32	110	42	11

7.2.2 Drilling Mud Parameters

There will be many changes in the drilling mud as an overpressured zone is entered. The main effects on the mud due to abnormal pressures will be:

- Increasing gas cutting of mud
- Decrease in mud weight
- Increase in flowline temperature

Since these effects can only be measured when the mud is returned to surface they involve a time lag of several hours in the detection of the overpressured zone. During the time it takes to circulate bottoms up, the bit could have penetrated quite far into an overpressured zone.

(a) Gas Cutting of Mud

Gas cutting of mud may happen in two ways:

- From shale cuttings - if gas is present in the shale being drilled the gas may be released into the annulus from the cuttings.

- Direct influx - this can happen if the overbalance is reduced too much, or due to
- Swabbing when pulling back the drillstring at connections.

Continuous gas monitoring of the mud is done by the mudlogger using gas chromatography. A degasser is usually installed as part of the mud processing equipment so that entrained gas is not re-cycled downhole or allowed to build up in the mud pits.

(b) Mud Weight

The mud weight measured at the flowline will be influenced by an influx of formation fluids. The presence of gas is readily identified due to the large decrease in density, but a water influx is more difficult to identify. Continuous measurement of mud weight may be done by using a radioactive densometer.

(c) Flowline Temperature

Under-compacted clays, with relatively high fluid content, have a higher temperature than other formations. By monitoring the flowline temperature therefore a decrease in temperature will be observed when drilling through normally pressured zones. This will be followed by an increase in temperature when the overpressured zones are encountered (Figure 16). The normal geothermal gradient is about 1 degree F/100 ft. It is reported that changes in flowline temperature up to 10 degree F/100 ft. have been detected when drilling overpressured zones.

When using this technique it must be remembered that other effects such as circulation rate, mud mixing, etc. can influence the mud temperature.

7.2.3 Drilled Cuttings

Since overpressured zones are associated with under-compacted shales with high fluid content the degree of overpressure can be inferred from the degree of compaction of the cuttings. The methods commonly used are:

- Density of shale cuttings
- Shale factor
- Shale slurry resistivity

Even the shape and size of cuttings may give an indication of overpressures (large cuttings due to low pressure differential). As with the drilling mud parameters these tests can only be done after a lag time of some hours.

(a) Density of Shale Cuttings

In normally pressured formations the compaction and therefore the bulk density of shales should increase uniformly with depth (given constant lithology). If the bulk density decreases, this may indicate an undercompacted zone which may be an overpressured zone. The bulk density of shale cuttings can be determined by using a mud balance. A sample of shale cuttings must first be washed and sieved (to remove cavings). These cuttings are then placed in the cup so that it balances at 8.3 ppg (equivalent to a full cup of water). At this point therefore:

$$\rho_s \times V_s = \rho_w \times V_t$$

where:

ρ_s = bulk density of shale

ρ_w = density of water

V_s = volume of shale cuttings

V_t = total volume of cup

The cup is then filled up to the top with water, and the reading is taken at the balance point (ρ). At this point

$$\rho V_t = \rho_s V_s + \rho_w (V_t - V_s)$$

Substituting for V_s from the first equation gives:-

$$\rho_s = \frac{\rho_w^2}{2\rho_w - \rho}$$

A number of such samples should be taken at each depth to check the density calculated as above and so improve the accuracy. The density at each depth can then be plotted (Figure 17).

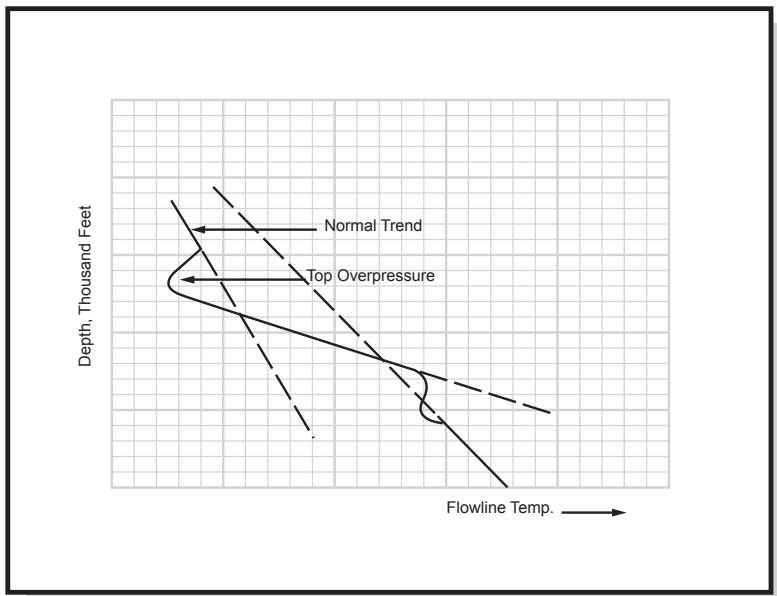

Figure 16 Flowline temperature to detect overpressure

(b) Shale Factor

This technique measures the reactive clay content in the cuttings. It uses the “methylene blue” dye test to determine the reactive montmorillonite clay present, and thus indicate the degree of compaction. The higher the montmorillonite, the lighter the density - indicating an undercompacted shale.

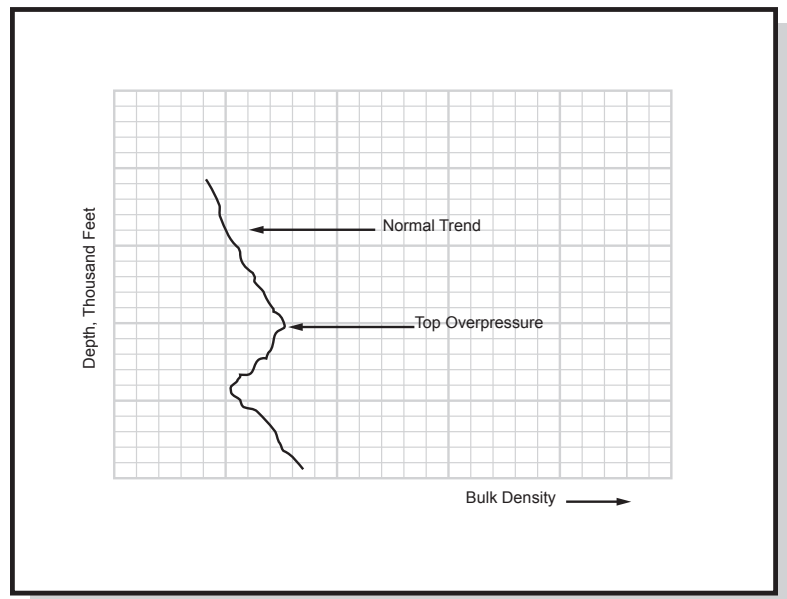

Figure 17 Bulk density to detect overpressure

(c) Shale Slurry Resistivity

As compaction increases with depth, water is expelled and so conductivity is reduced. A plot of resistivity against depth should show a uniform increase in resistivity, unless an undercompacted zone occurs where the resistivity will reduce. To measure the resistivity of shale cuttings a known quantity of dried shale is mixed with a known volume of distilled water. The resistivity can then be measured and plotted (Figure 18).

7.3 Confirmation Techniques

After the hole has been successfully drilled certain electric wireline logs and pressure surveys may be run to confirm the presence of overpressures. The logs which are particularly sensitive to undercompaction are : the sonic, density and neutron logs. If an overpressured sand interval has been penetrated then the pressure in the sand can be measured directly with a repeat formation tester or by conducting a well test.

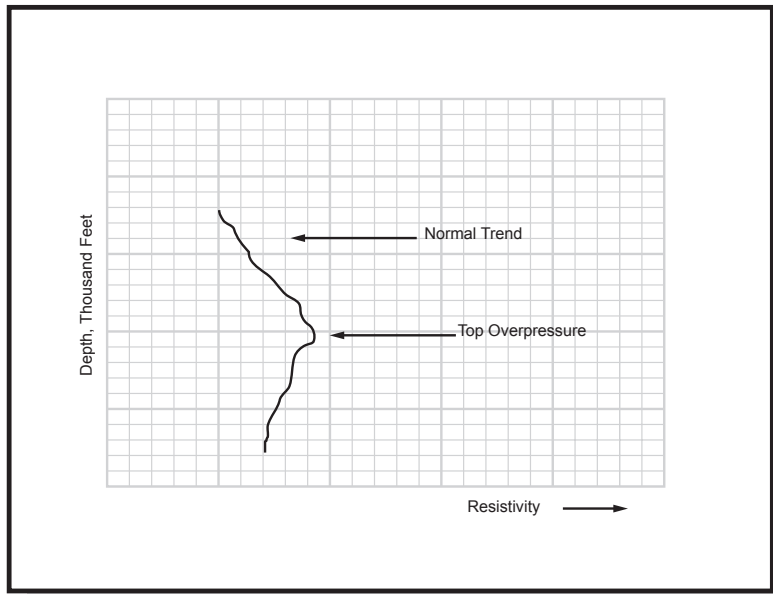

Figure 18 Resistivity. to detect overpressure

8. FORMATION FRACTURE GRADIENT

When planning the well, both the formation pore pressure and the formation fracture pressure for all of the formations to be penetrated must be estimated (Figure 19). The well operations can then be designed such that the pressures in the borehole will always lie between the formation pore pressure and the fracture pressure. If the pressure in the borehole falls below the pore pressure then an influx of formation fluids into the wellbore may occur. If the pressure in the borehole exceeds the fracture pressure then the formations will fracture and losses of drilling fluid will occur.

8.1 Mechanism of Formation Breakdown

The stress within a rock can be resolved into three principal stresses (Figure 20). A formation will fracture when the pressure in the borehole exceeds the least of the stresses within the rock structure. Normally, these fractures will propagate in a direction perpendicular to the least principal stress (Figure 20). The direction of the least principal stress in any particular region can be predicted by investigating the fault activity in the area (Figure 21).

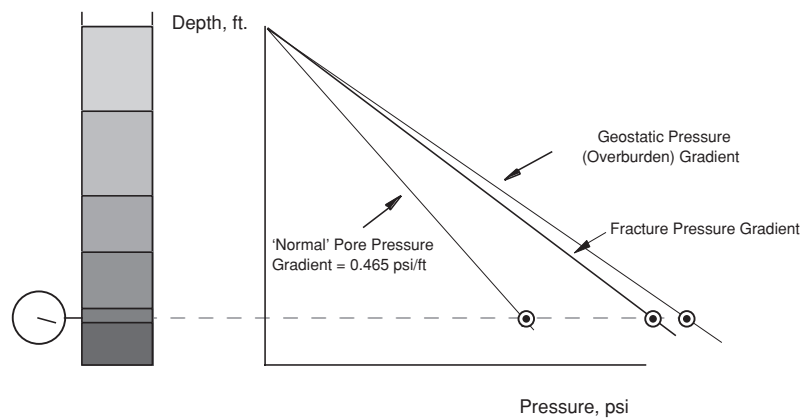

Figure 19 Pore Pressure, Fracture Pressure and Overburden Pressures and Gradients for a Particular Formation

To initiate a fracture in the wall of the borehole, the pressure in the borehole must be greater than the least principal stress in the formation. To propagate the fracture the pressure must be maintained at a level greater than the least principal stress.

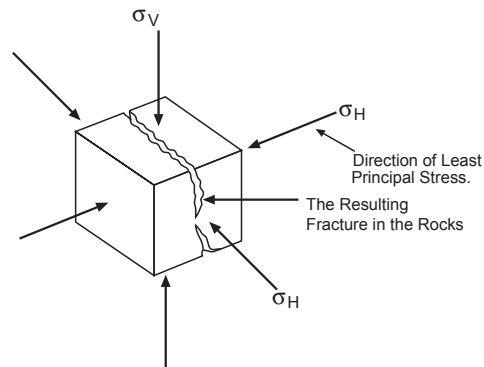

Figure 20 Idealised view of the stresses acting on the block

8.2 The Leak-Off Test, Limit Test and Formation Breakdown Test

The pressure at which formations will fracture when exposed to borehole pressure is determined by conducting one of the following tests:

- Leak-off test
- Limit Test
- Formation Breakdown Test

The basic principle of these tests is to conduct a pressure test of the entire system in the wellbore (See Figure 21) and to determine the strength of the weakest part of this system on the assumption that this formation will be the weakest formation in the subsequent open hole. The wellbore is comprised of (from bottom to top): the exposed formations in the open hole section of the well (generally only 5-10ft of formation is exposed when these tests are conducted); the casing (and connections);



the wellhead; and the BOP stack. The procedure used to conduct these tests is basically the same in all cases. The test is conducted immediately after a casing has been set and cemented. The only difference between the tests is the point at which the test is stopped. The procedure is as follows:

1. Run and cement the casing string
2. Run in the drillstring and drillbit for the next hole section and drill out of the casing shoe
3. Drill 5 - 10 ft of new formation below the casing shoe
4. Pull the drillbit back into the casing shoe (to avoid the possibility of becoming stuck in the openhole)
5. Close the BOPs (generally the pipe ram) at surface
6. Apply pressure to the well by pumping a small amount of mud (generally 1/2 bbl) into the well at surface. Stop pumping and record the pressure in the well. Pump a second, equal amount of mud into the well and record the pressure at surface. Continue this operation, stopping after each increment in volume and recording the corresponding pressure at surface. Plot the volume of mud pumped and the corresponding pressure at each increment in volume. (Figure 22).

(Note: the graph shown in Figure 21 represents the pressure all along the wellbore at each increment. This shows that the pressure at the formation at leak off is the sum of the pressure at surface plus the hydrostatic pressure of the mud).

7. When the test is complete, bleed off the pressure at surface, open the BOP rams and drill ahead

It is assumed in these tests that the weakest part of the wellbore is the formations which are exposed just below the casing shoe. It can be seen in Figure 21, that when these tests are conducted, the pressure at surface, and throughout the wellbore, initially increases linearly with respect to pressure. At some pressure the exposed formations start to fracture and the pressure no longer increases linearly for each increment in the volume of mud pumped into the well (see point A in Figure 22). If the test is conducted until the formations fracture completely (see point B in Figure 22) the pressure at surface will often drop dramatically, in a similar manner to that shown in Figure 22.

The precise relationship between pressure and volume in these tests will depend on the type of rock that is exposed below the shoe. If the rock is ductile the behaviour will be as shown in Figure 22 and if it is brittle it will behave as shown in Figure 23.

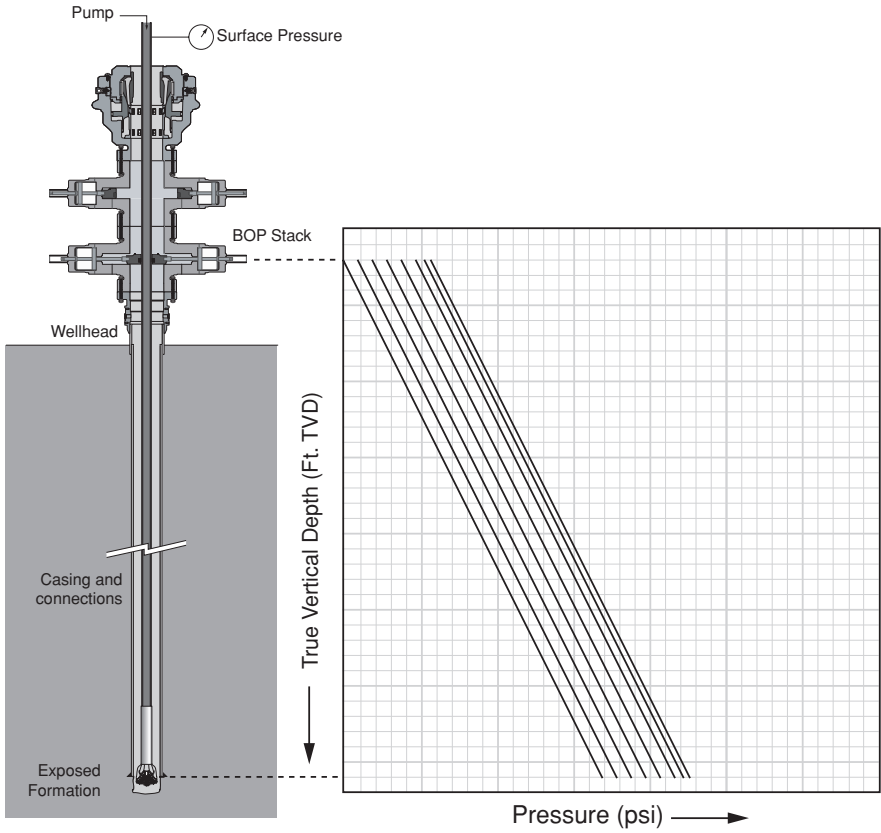

Figure 21 Configuration during formation integrity tests

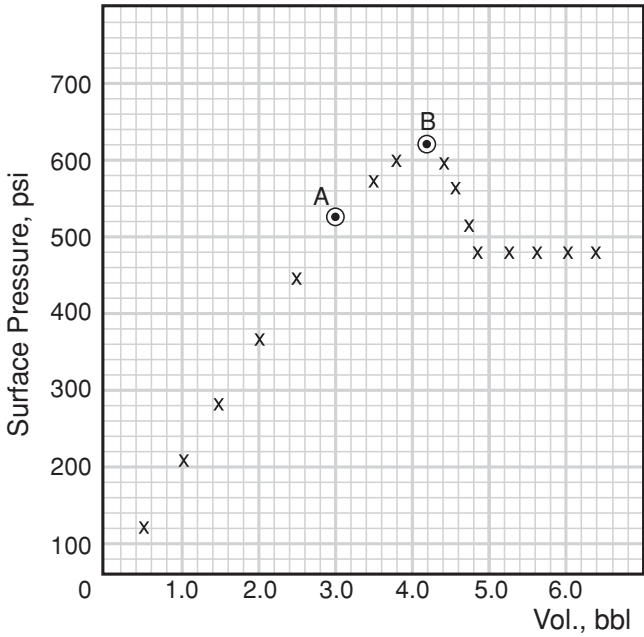

Figure 22 Behaviour of a ductile rock

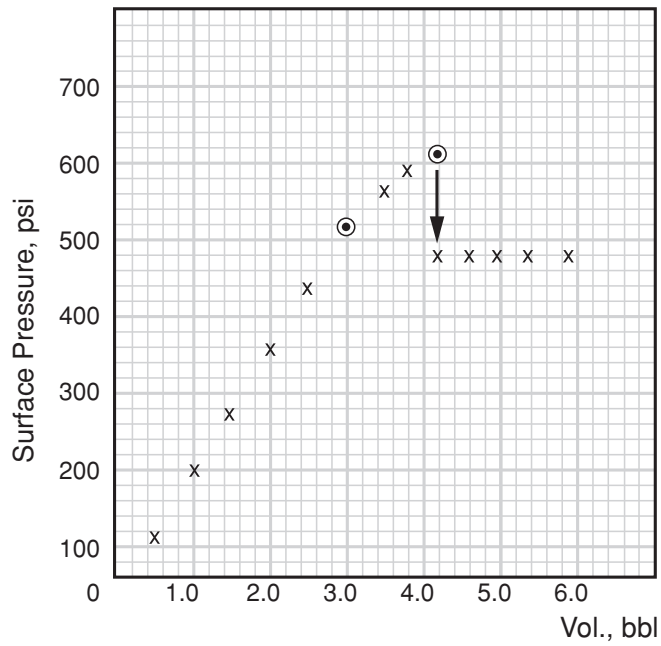

Figure 23 Behaviour of a brittle rock

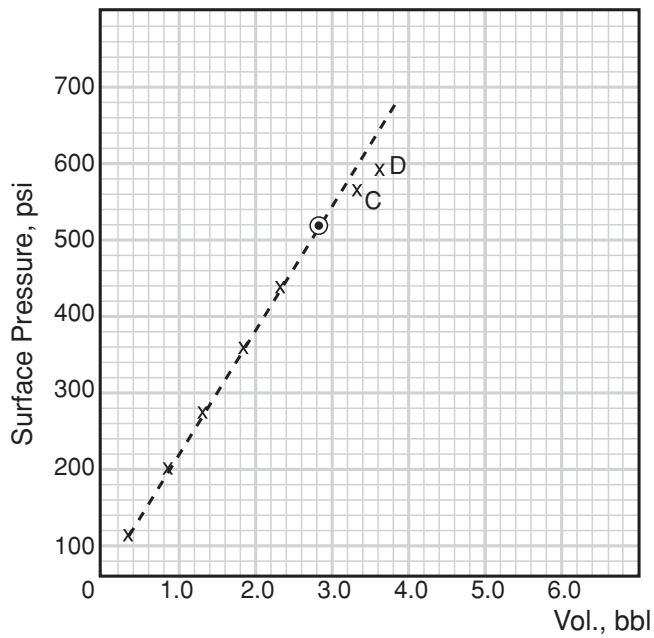

Figure 24 P-V behaviour during a leak off test

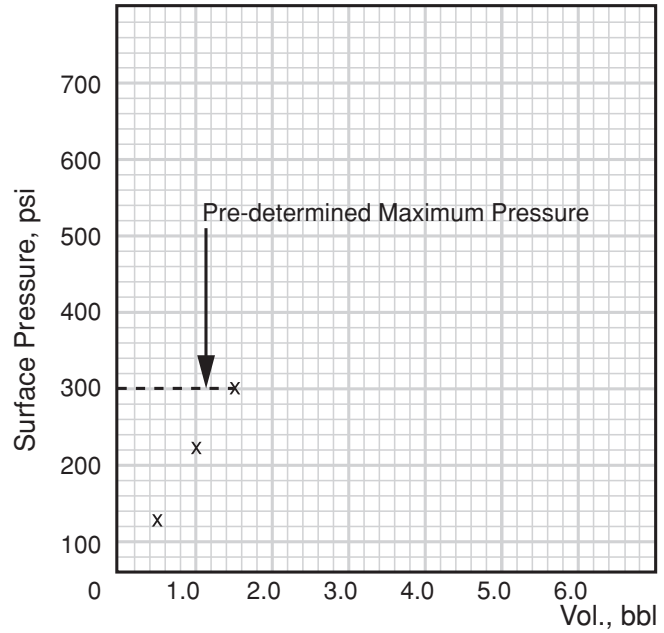

Figure 25 P-V behaviour in a limit test

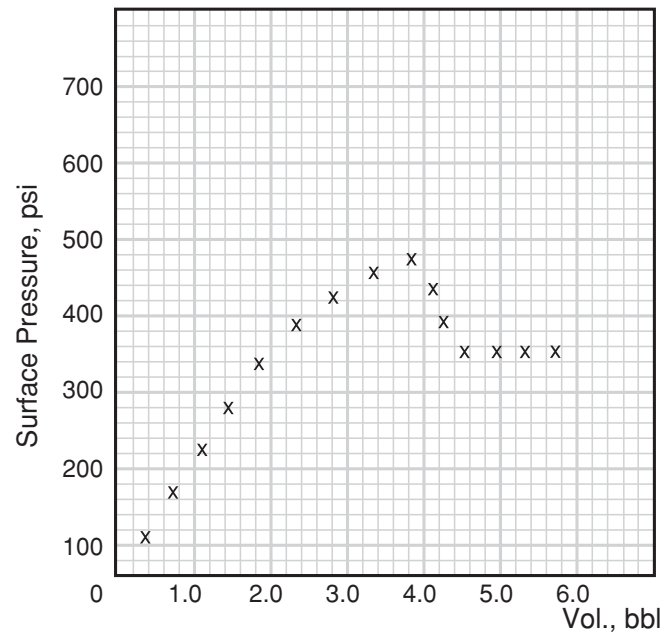

Figure 26 Behaviour in a FBT test



The “**Leak-off test**” is used to determine the pressure at which the rock in the open hole section of the well **just starts to break down** (or “leak off”). In this type of test the operation is terminated when the pressure no longer continues to increase linearly as the mud is pumped into the well (See Figure 24). In practice the pressure and volume pumped is plotted in real time, as the fluid is pumped into the well. When it is seen that the pressure no longer increases linearly with an increase in volume pumped (Point C) it is assumed that the formation is starting to breakdown. When this happens a second, smaller amount of mud (generally 1/4 bbl) is pumped into the well just to check that the deviation from the line is not simply an error (Point D). If it is confirmed that the formation has started to “leak off” then the test is stopped and the calculations below are carried out.

The “**Limit Test**” is used to determine whether the rock in the open hole section of the well will withstand a **specific**, predetermined pressure. This pressure represents the maximum pressure that the formation will be exposed to whilst drilling the next wellbore section. The pressure to volume relationship during this test is shown in Figure 25. This test is effectively a limited version of the leak-off test.

The “**Formation Breakdown Test**” is used to determine the pressure at which the rock in the open hole section of the well completely breaks down. If fluid is continued to be pumped into the well after leak off and breakdown occurs the pressure in the wellbore will behave as shown in Figure 26.

8.2.1 Leak Off Test Calculations

In a Leak-Off test the formation below the casing shoe is considered to have started to fracture at point A on Figure 24. The surface pressure at point A is known as the leak off pressure and can be used to determine the maximum allowable pressure on the formation below the shoe. The maximum allowable pressure at the shoe can subsequently be used to calculate:

- The maximum mudweight which can be used in the subsequent openhole section
- The Maximum Allowable Annular Surface Pressure (MAASP)

The maximum allowable pressure on the formation just below the casing shoe is generally expressed as an **equivalent mud gradient (EMG)** so that it can be compared with the mud weight to be used in the subsequent hole section.

Given the pressure at surface when leak off occurs (point A in Figure 24) just below the casing shoe, the maximum mudweight that can be used at that depth, and below, can be calculated from :

$$\begin{aligned} & \text{Maximum Mudweight (psi/ft)} \\ & = \frac{\text{Pressure at the shoe when Leak-off occurs}}{\text{True Vertical Depth of the shoe}} \\ & = \frac{\text{Pressure at surface and hydrostatic pressure of mud in well}}{\text{True Vertical Depth of the shoe}} \end{aligned}$$

Usually a safety factor of 0.5 ppg (0.026 psi/ft) is subtracted from the allowable mudweight.

It should be noted that the leak-off test is usually done just after drilling out of the casing shoe, but when drilling the next hole section other, weaker formations may be encountered.

Example

While performing a leak off test the surface pressure at leak off was 940 psi. The casing shoe was at a true vertical depth of 5010 ft and a mud weight of 10.2 ppg was used to conduct the test.

The Maximum bottom hole pressure during the leakoff test can be calculated from:

$$\begin{aligned} &\text{hydrostatic pressure of colom of mud} + \text{leak off pressure at surface} \\ &= (0.052 \times 10.2 \times 5010) + 940 \\ &= 3597 \text{ psi} \end{aligned}$$

the maximum allowable mud weight at this depth is therefore

$$\begin{aligned} &= \frac{3597 \text{ psi}}{5010 \text{ ft}} \\ &= 0.718 \text{ psi/ft} = 13.8 \text{ ppg} \end{aligned}$$

Allowing a safety factor of 0.5 ppg,

The maximum allowable mud weight = 13.8 - 0.5 = 13.3 ppg.

8.2.2 The Equivalent Circulating Density (ECD) of a fluid

It is clear from all of the preceding discussion that the pressure at the bottom of the borehole must be accurately determined if the leak off or fracture pressure of the formation is not to be exceeded. When the drilling fluid is circulating through the drillstring, the borehole pressure at the bottom of the annulus will be greater than the hydrostatic pressure of the mud. The extra pressure is due to the frictional pressure required to pump the fluid up the annulus. This frictional pressure must be added to the pressure due to the hydrostatic pressure from the colom of mud to get a true representation of the pressure acting against the formation a the bottom of the well. An **equivalent circulating density (ECD)** can then be calculated from the sum of the hydrostatic and frictional pressure divided by the true vertical depth of the well. The ECD for a system can be calculated from:

$$\text{ECD} = \frac{\text{MW} + P_d}{0.052 \times D}$$

where ,

ECD= effective circulating density (ppg)

MW= mud weight (ppg)



P_d = annulus frictional pressure drop at a given circulation rate (psi)

D = depth (ft)

The ECD of the fluid should be continuously monitored to ensure that the pressure at the formation below the shoe, due to the ECD of the fluid and system, does not exceed the leak off test pressure.

8.2.3 MAASP

The Maximum Allowable Annular Surface Pressure - MAASP - when drilling ahead is the maximum closed in (not circulating) pressure that can be applied to the annulus (drillpipe x BOP) at surface before the formation just below the casing shoe will start to fracture (leak off). The MAASP can be determined from the following equation:

MAASP = **Maximum Allowable** pressure at the formation just below the shoe minus the Hydrostatic Pressure of mud at the formation just below the shoe.

Exercise 3 Leak - Off Test

A leakoff test was carried out just below a 13 3/8" casing shoe at 7000 ft. TVD using 9.0 ppg mud. The results of the tests are shown below. What is the maximum allowable mudweight for the 12 1/4" hole section ?

BBLS PUMPED	SURFACE PRESSURE (psi)
1	400
1.5	670
2	880
2.5	1100
3	1350
3.5	1600
4	1800
4.5	1900
5	1920

Exercise 4 Equivalent Circulating Density - ECD

If the circulating pressure losses in the annulus of the above well is 300 psi when drilling at 7500ft with 9.5ppg mud, what would be the ECD of the mud at 7500ft.

Exercise 5 Maximum Allowable Annular Surface Pressure - MAASP

If a mudweight of 9.5ppg is required to drill the 12 1/4" hole section of the above well what would the MAASP be when drilling this hole section?

8.3 Calculating the Fracture Pressure of a Formation

The leak-off test pressure described above can only be determined after the formations to be considered have been penetrated. It is however necessary, in order to ensure a safe operation and to optimise the design of the well, to have an estimate of the fracture pressure of the formations to be drilled before the drilling operation has been commenced. In practice the fracture pressure of the formations are estimated from leakoff tests on nearby (offset) wells.

Many attempts have been made to predict fracture pressures. The fracture pressure of a formation drilled through a normally pressured formation can be determined from the following equations:

- vertical well and $\sigma_2 = \sigma_3$

$$FBP = 2\sigma_3 - p_o$$

- vertical well and $\sigma_2 > \sigma_3$:

$$FBP = 3\sigma_3 - \sigma_2 - p_o$$

- deviated well and $\sigma_2 = \sigma_3$

$$FBP = 2\sigma_3 - (\sigma_1 - \sigma_3)\sin^2\theta_z - p_o$$

- deviated well in the direction of σ_2 and $\sigma_2 > \sigma_3$

$$FBP = 3\sigma_3 - \sigma_2 - (\sigma_1 - \sigma_3)\sin^2\theta_z - p_o$$

where,

- FBP = Formation Breakdown Pressure
- σ_1 = Overburden Stress (psi)
- σ_2 = Horizontal stress (psi)
- σ_3 = Horizontal stress (psi)
- p_o = Pore Pressure (psi)
- θ_z = Hole Deviation

If the conservative assumption that the formation is already fractured is made then the equations used to calculate the fracture pressure of the formations are simplified significantly.

Eaton proposed the following equation for fracture gradients :

$$G_f = [G_o - G_p] \left[\frac{\nu}{1 - \nu} \right] + G_p$$

where,

- G_f = fracture gradient (psi/ft)
- G_o = overburden gradient (psi/ft)
- G_p = pore pressure gradient (observed or predicted) (psi/ft)
- ν = Poisson's ratio

Poisson's ratio is a rock property that describes the behaviour of rock stresses (σ_1) in one direction (least principal stress) when pressure (σ_p) is applied in another direction (principal stress).

$$\frac{\sigma_1}{\sigma_p} = \frac{\nu}{1 - \nu}$$

Laboratory tests on unconsolidated rock have shown that generally:

$$\frac{\sigma_1}{\sigma_p} = \frac{1}{3}$$

Field tests however show that ν may range from 0.25 to 0.5 at which point the rock becomes plastic (stresses equal in all directions). Poisson's ratio varies with depth and degree of compaction (Figure 27).

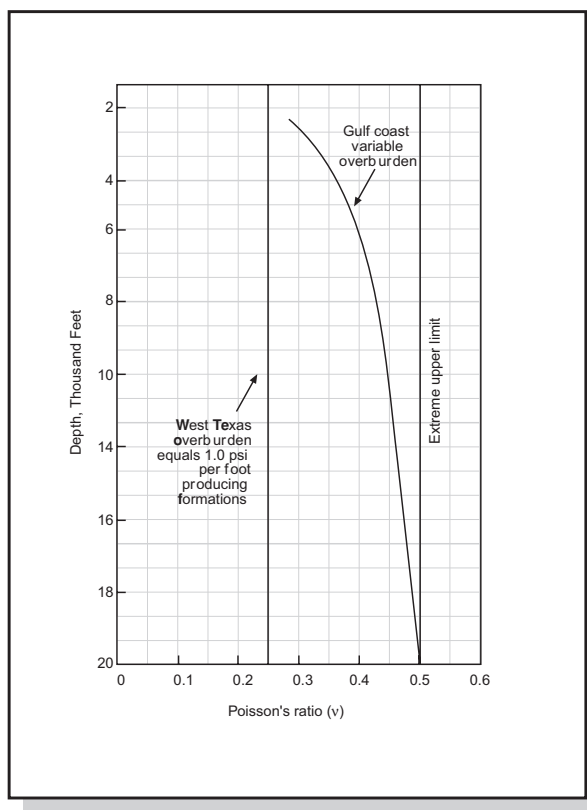

Figure 27 Variation of Poisson's ratio with depth. Above $\nu = 0.5$ the rocks become plastic

Matthews and Kelly proposed the following method for determination of fracture pressures in sedimentary rocks:

$$G_f = G_p + \frac{\sigma K_i}{D}$$

where:

- G_f = fracture gradient (psi/ft)
- G_p = pore pressure gradient psi/ft
- K_i = matrix stress coefficient
- σ = matrix stress (psi)
- D = depth of interest (ft)

The matrix stress (σ) can be calculated as the difference between overburden pressure, S and pore pressure, P .

$$\text{i.e. } \sigma = S - P$$

The coefficient K_i relates the actual matrix stress to the “normal” matrix stress and can be obtained from charts.

Exercise 6 Fracture Pressure Prediction - Eaton Equation

The following information has been gathered together in an attempt to predict the fracture pressure of a formation to be drilled at 8500ft:

Vertical Depth of formation	= 8500 ft.
Pore Pressure	= 5300 psi
Overburden pressure	= 7800 psi
Poissons Ratio	= 0.28 (Determined from laboratory tests on core)

- a. Calculate the fracture pressure of the formation at 8500ft.
- b. How would the fracture pressure of the formation at 8500ft be confirmed or otherwise when the formation has been drilled ?

8.4 Summary of Procedures

When planning a well the formation pore pressures and fracture pressures can be predicted from the following procedure:

1. Analyse and plot log data or d-exponent data from an offset (nearby) well.
2. Draw in the normal trend line, and extrapolate below the transition zone.
3. Calculate a typical overburden gradient using density logs from offset wells.
4. Calculate formation pore pressure gradients from equations (e.g. Eaton).
5. Use known formation and fracture gradients and overburden data to calculate a typical Poisson’s ratio plot.
6. Calculate the fracture gradient at any depth.

Basically the three gradients must be estimated to assist in the selection of mud weights and in the casing design. One example is shown in Figure 28. Starting at line A representing 18 ppg mud it can be seen that any open hole shallower than 10,200' will be fractured. Therefore a protective casing or liner must be run to seal off that shallower section before 18 ppg mud is used to drill below 10200'.

To drill to 10,200' a 16 ppg mud (line B) must be used. This mud will breakdown any open hole above about 8,300'(line C). This defines the setting depth of the protective casing (and the height of the liner).

To drill to 8,300' a 13 ppg mud is required (line E). This mud will breakdown any open hole above 2,500', so this defines the surface casing shoe. Note that casing shoes are usually set below indicated breakdown points as an added safety factor.

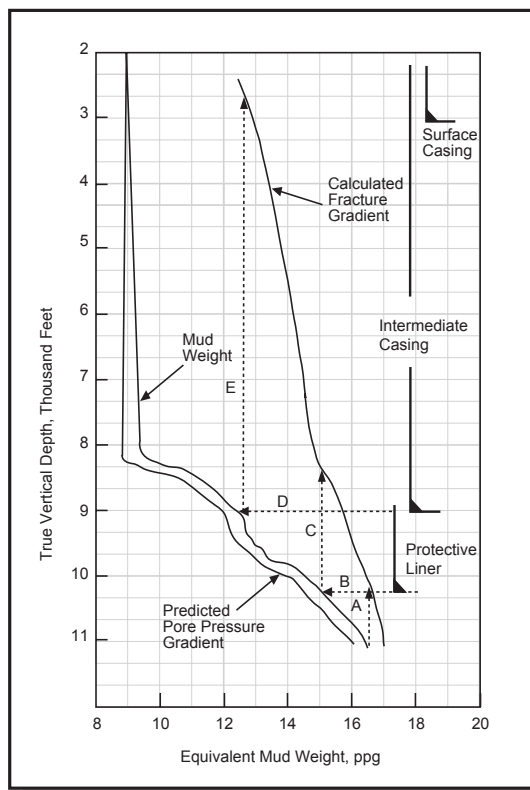
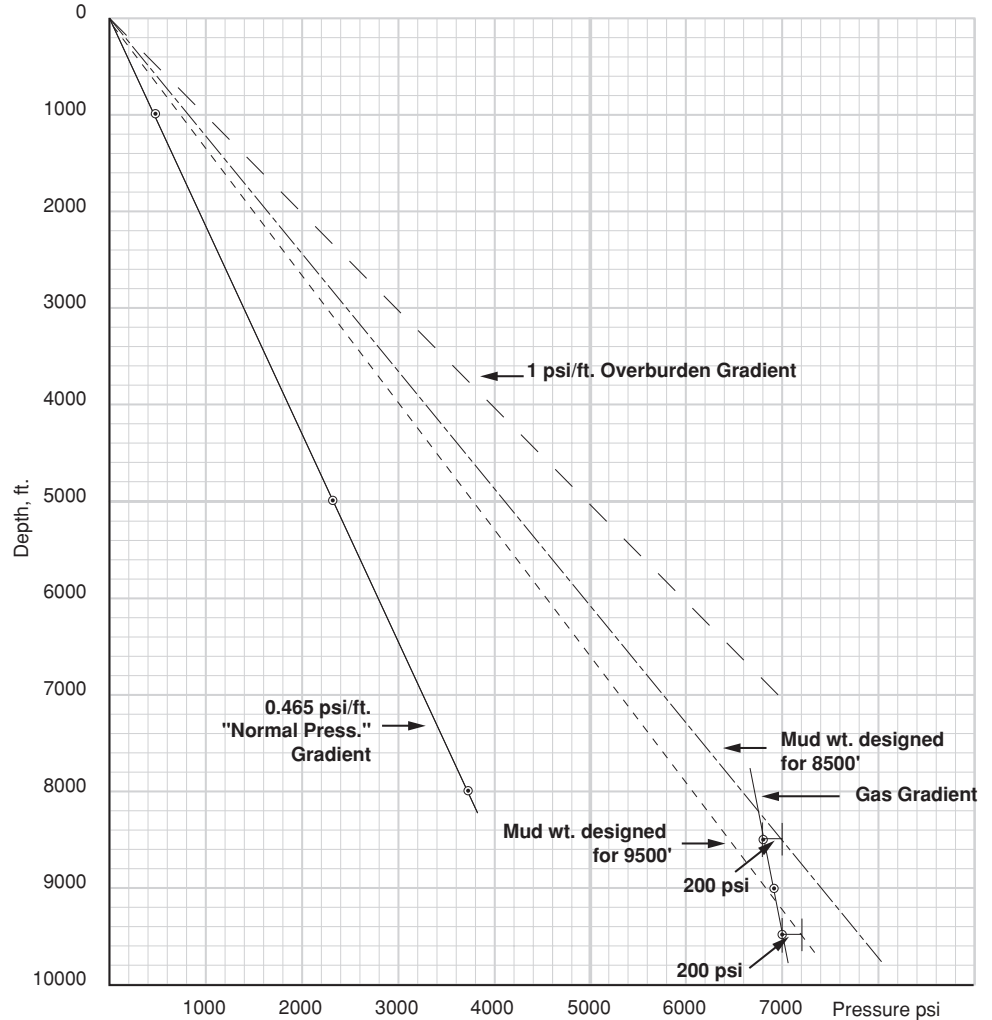

Figure 28 Example of how pore pressure and fracture gradients can be used to select casing seats

Solutions to Exercises

Exercise 1 Pore Pressure Profiles



b. The pore pressure gradients in the formations from surface are:

$$0 - 8000 \text{ ft} \quad 3720/8000 = 0.465 \text{ psi/ft}$$

$$0 - 8500 \text{ ft} \quad 6850/8500 = 0.800 \text{ psi/ft}$$

$$0 - 9500 \text{ ft} \quad 6900/9500 = 0.726 \text{ psi/ft}$$

Required Mudweight:

$$\begin{aligned} @ 8000 \text{ ft} \\ 3720 + 200 &= 3920 \text{ psi} \\ 3920/8000 &= 0.49 \text{ psi/ft} \Rightarrow 9.42 \text{ ppg} \end{aligned}$$

$$\begin{aligned} @ 8500 \text{ ft} \quad 6800 + 200 &= 7000 \text{ psi} \\ 7000/8500 &= 0.82 \text{ psi/ft} = 15.77 \text{ ppg} \end{aligned}$$

$$\begin{aligned} @ 9500 \text{ ft} \quad 6900 + 200 &= 7100 \text{ psi} \\ 7100/9500 &= 0.75 \text{ psi/ft} = 14.42 \text{ ppg} \end{aligned}$$



- c. If the mudweight of were 9.42 ppg were used to drill at 8500 ft the underbalance would be:

$$6800 - (8500 \times 9.42 \times 0.052) = \mathbf{2636 \text{ psi}}$$

Hence the borehole pressure is 2636 psi less than the formation pressure.

- d. If, when using 0.82 psi/ft (or 15.77 ppg) mud for the section at 8500ft, the fluid level in the hole dropped to 500ft the bottom hole pressure would fall by:

$$500 \times 0.82 = \mathbf{410 \text{ psi}}$$

Hence the pressure in the borehole would be 210 psi below the formation pressure.

- e. The density of the fluid in the formation between 8500 and 9500 ft is:

$$\frac{6900 - 6800}{1000} = 0.1 \text{ psi/ft}$$

The fluid in the formations below 8500 ft is therefore **gas**.

Exercise 2 'd' and 'dc' Exponent

Whilst drilling this section of 12 1/4" hole the mudloggers were also recording data which would allow them to plot the d and d_c exponents for this shale section. This data is compiled and the d and d_c exponents calculated as shown in Table 2.1. A plot of the d and d_c exponents in Figure 2.1 and 2.2 confirms that the top of the overpressured zone is at 8000 ft.

d EXPONENT

BIT SIZE	IN.	12.25
NORMAL MUDWEIGHT	PPG	9.5
OVERBURDEN GRAD.	PPG	19.3
FORM. GRAD.	PPG	8.9

DEPTH FT.	ROP FT/HR	RPM	WOB 000 LBS	d EXPONENT	MUDWEIGHT PPG	dc EXPONENT
7500	125	120	38	1.23	9.5	1.23
7600	103	120	38	1.29	9.5	1.29
7700	77	110	38	1.35	9.5	1.35
7800	66	110	38	1.40	9.6	1.38
7900	45	110	35	1.48	9.6	1.46
8000	37	110	37	1.56	9.3	1.60
8100	40	110	35	1.51	9.8	1.47
8200	42	110	33	1.47	9.9	1.41
8300	41	100	33	1.45	10	1.38
8400	44	100	38	1.49	10.25	1.38
8500	34	100	38	1.57	10.25	1.46
8600	33	100	40	1.61	11	1.39
8700	32	110	42	1.67	11	1.44

From the attached plot of the above data the top of the overpressured zone is 8000 ft.

Table 2.1 d and d_c Exponent

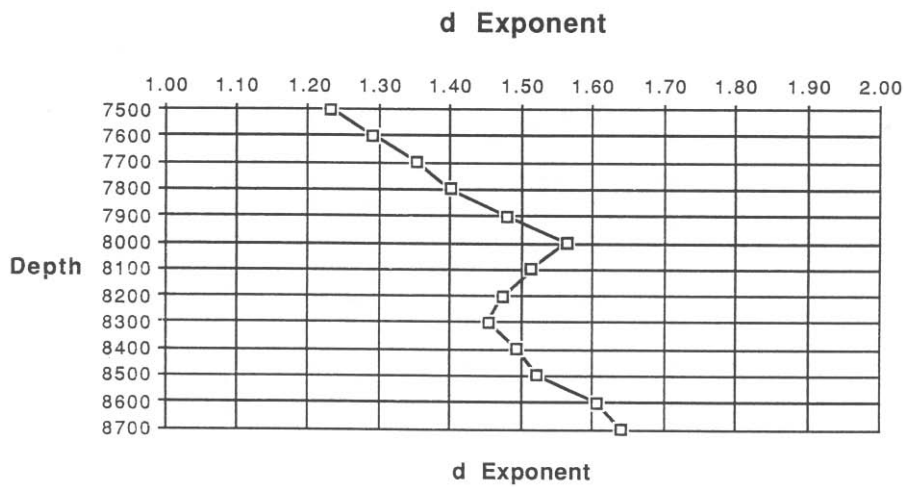

Figure 2.1 d Exponent Plot

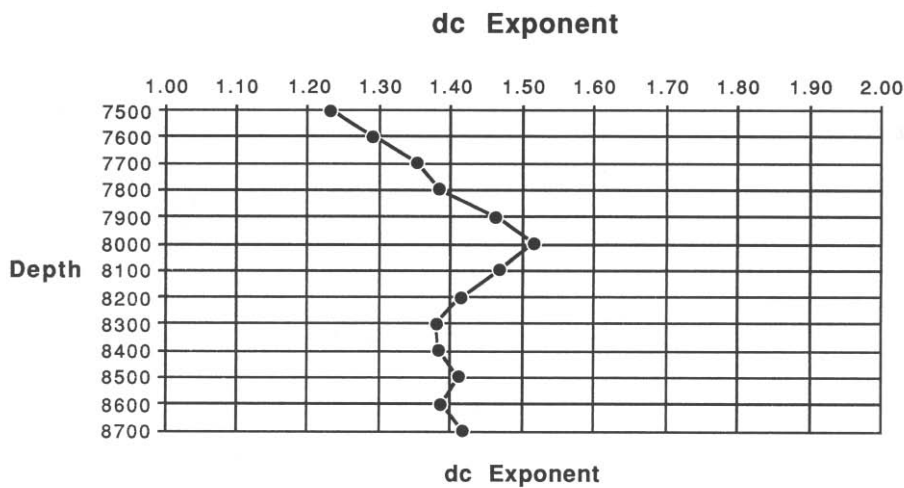

Figure 2.2 d_c Exponent Plot

Exercise 3 Leak-Off Test

After drilling out of the 13 3/8" shoe, but before drilling ahead the 12 1/4" hole a leak off test was performed. It can be seen from Figure 3.1 that at 1800 psi surface pressure the uniform increase in mud volume pumped into the hole did not result in a linear increase in the pressure observed at surface. This is an indication that the formation at the casing shoe has failed and that the fluid pumped into the well is escaping into fractures in the formation.

The maximum pressure that the formation will withstand at the shoe (assumed to be the weakest point in the next hole section) is therefore 1800 psi with 9 ppg mud in the hole. Thus the maximum absolute pressure that the formation will withstand (with zero surface pressure) is:

$$(9 \times 0.052 \times 7000) + 1800 = 5076 \text{ psi.}$$

The maximum allowable mudweight that can be used in the next hole section is:

$$\begin{aligned} 5076/7000 &= 0.73 \text{ psi/ft} \\ &= 13.95 \text{ ppg} \end{aligned}$$

If it is anticipated that a mudweight greater than this is required then consideration should be given to setting another string of casing prior to entering the zone that will require this higher mudweight. A safety margin of 0.5 ppg underweight is generally subtracted from the allowable mudweight calculated above.

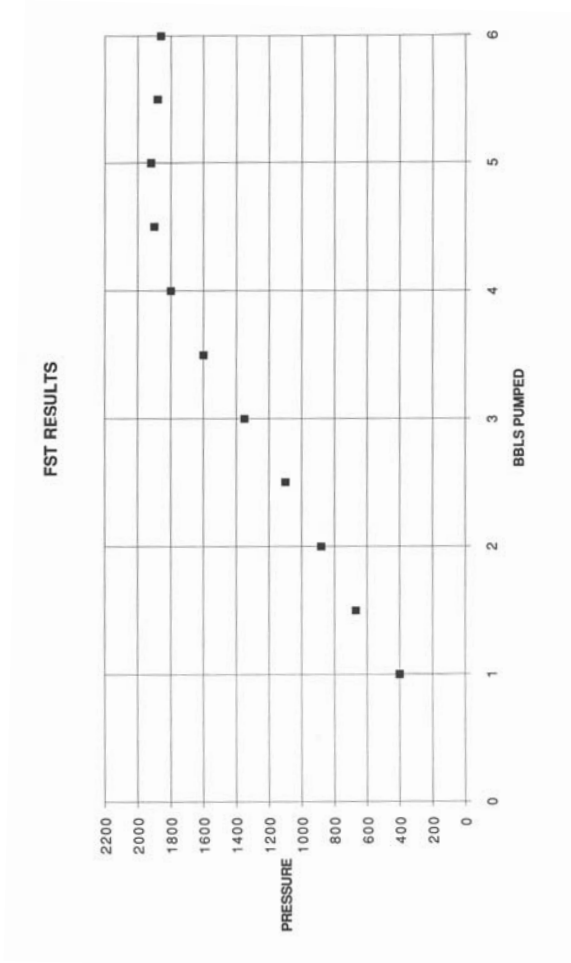

Figure 3.1 FST Results

Exercise 4 Equivalent Circulating Density - ECD

If the circulating pressure losses in the annulus of the above well are 300 psi when drilling at 7500ft, the ECD of a 9.5 ppg mud at 7500ft would be:

$$9.5 + (300/7500)/0.052 = 10.27 \text{ ppg}$$



Exercise 5 Maximum Allowable Annular Surface Pressure - MAASP

If a mudweight of 9.5ppg mud is required to drill the 12 1/4" hole section of the above well, the MAASP when drilling this hole section would be:

The maximum allowable mudweight in the next hole section (Exercise 3 above) is 13.95 ppg

The pressure at the casing shoe with 13.95 ppg mud :

$$13.95 \times 0.052 \times 7000 = 5078 \text{ psi}$$

The pressure at the casing shoe with 9.5 ppg mud :

$$9.5 \times 0.052 \times 7000 = 3458 \text{ psi}$$

The MAASP is therefore = $5078 - 3458 = \mathbf{1620 \text{ psi}}$

Well Control 6

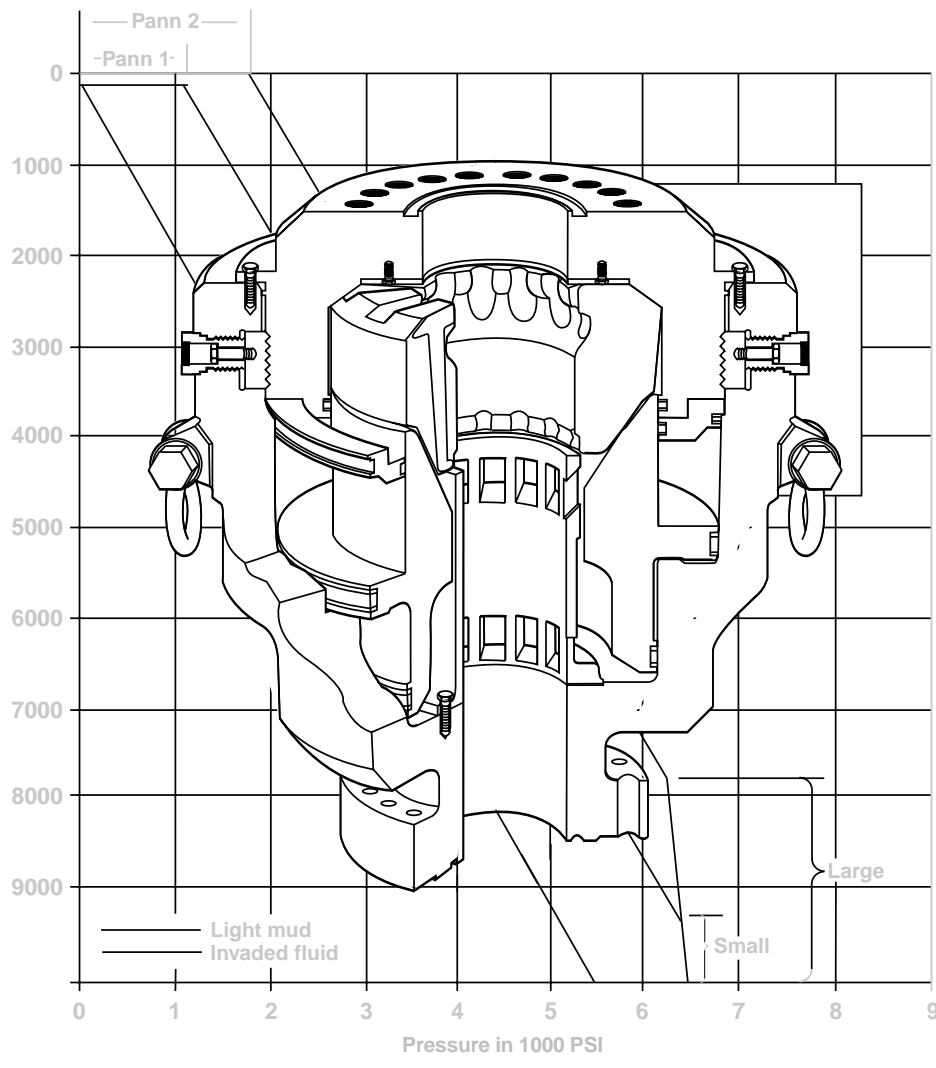

CONTENTS

1. INTRODUCTION
2. PRIMARY CONTROL
 - 2.1 Reduction in Mudweight
 - 2.2 Reduced Height of Mud Colom
3. WARNING SIGNS OF KICKS
 - 3.1 Primary Indicators of a Kick
 - 3.2 Secondary Indicators
 - 3.3 Precautions Whilst Drilling
 - 3.4 Precautions During Tripping
4. SECONDARY CONTROL
 - 4.1 Shut in Procedure
 - 4.2 Interpretation of Shut-in Pressures
 - 4.3 Formation Pore Pressure
 - 4.4 Kill Mud Weight
 - 4.5 Determination of the Type of Influx
 - 4.6 Factors Affecting the Annulus Pressure, P_{ann}
 - 4.8 MAASP
5. WELL KILLING PROCEDURES
 - 5.1 Drillstring out of the Well
 - 5.2 Drillstring in the Well
 - 5.3 One Circulation Well Killing Method
 - 5.4 Drillers Method for Killing a Well
6. BOP EQUIPMENT
 - 6.1 Annular Preventers
 - 6.2 Ram Type Preventers
 - 6.3 Drilling Spools
 - 6.4 Casing Spools
 - 6.5 Diverter System
 - 6.6 Choke and Kill Lines
 - 6.7 Choke Manifold
 - 6.8 Choke Device
 - 6.9 Hydraulic Power Package (Accumulators)
 - 6.10 Internal Blow-out Preventers
7. BOP STACK ARRANGEMENTS
 - 7.1 General considerations
 - 7.2 API Recommended Configurations
 - 7.2.1 Low Pressure (2000 psi WP)
 - 7.2.2 Normal Pressure (3000 or 5000 psi WP)
 - 7.2.3 Abnormally High Pressure (10000 or 15000 psi WP)





LEARNING OBJECTIVES:

Having worked through this chapter the student will be able to :

General:

- Describe and prioritise the implications of a blowout
- Define the terms: kick; blowout; primary and secondary control; BOP; BOP Stack

Primary Well Control:

- List and describe the common reasons for loss of primary control
- Describe the impact of gas entrainment on mudweight
- Calculate the ECD of the mud and describe the impact of mudweight on lost circulation.

Kick Detection and control:

- List and describe the warning signs of a kick
- Identify the primary and secondary indicators and describe the rationale behind their interpretation.
- Describe the operations which must be undertaken when a kick is detected.
- Describe the precautions which must be taken when tripping

Secondary Control:

- Describe the procedure for controlling a kick when drilling and when tripping.
- Describe the one circulation and drillers method for killing a well.
- Describe the manner in which the drillpipe and annulus pressure vary when killing the well with both the one circulation and drillers method.
- Calculate: the formation pressure; the mudweight required to kill the well; and the density (nature) of the influx.
- Describe the implications for the annulus pressure of: the volume of the kick; a gas bubble rising in the annulus when shut-in

Well Control Equipment:

- Describe the equipment used to control the well after a kick has occurred
- Describe the ways in which the BOP stack can be configured and the advantages and disadvantages of each of the configurations.

1. INTRODUCTION

This chapter will introduce the procedures and equipment used to ensure that fluid (oil, gas or water) does not flow in an uncontrolled way from the formations being drilled, into the borehole and eventually to surface. This flow will occur if the pressure in the pore space of the formations being drilled (the **formation pressure**) is greater than the hydrostatic pressure exerted by the column of mud in the wellbore (the **borehole pressure**). It is essential that the borehole pressure, due to the column of fluid, exceeds the formation pressure at all times during drilling. If, for some reason, the formation pressure is greater than the borehole pressure an influx of fluid into the borehole (known as a **kick**) will occur. If no action is taken to stop the influx of fluid once it begins, then all of the drilling mud will be pushed out of the borehole and the formation fluids will be flowing in an uncontrolled manner at surface. This would be known as a **Blowout**. This flow of the formation fluid to surface is prevented by the **secondary control** system. Secondary control is achieved by closing off the well at surface with valves, known as **Blowout Preventers - BOPs**.

The control of the formation pressure, either by ensuring that the borehole pressure is greater than the formation pressure (known as **Primary Control**) or by closing off the BOP valves at surface (known as **Secondary Control**) is generally referred to as keeping the pressures in the well under control or simply **well control**.

When pressure control over the well is lost, swift action must be taken to avert the severe consequences of a blow-out. These consequences may include:

- Loss of human life
- Loss of rig and equipment
- Loss of reservoir fluids
- Damage to the environment
- Huge cost of bringing the well under control again.

For these reasons it is important to understand the principles of well control and the procedures and equipment used to prevent blowouts. Every operating company will have a policy to deal with pressure control problems. This policy will include training for rig crews, regular testing of BOP equipment, BOP test drills and standard procedures to deal with a kick and a blow-out.

One of the basic skills in well control is to recognise when a kick has occurred. Since the kick occurs at the bottom of the borehole its occurrence can only be inferred from signs at the surface. The rig crew must be alert at all times to recognise the signs of a kick and take immediate action to bring the well back under control.

The severity of a kick (amount of fluid which enters the wellbore) depends on several factors including the: type of formation; pressure; and the nature of the influx. The higher the permeability and porosity of the formation, the greater the potential for a severe kick (e.g. sand is considered to be more dangerous than a shale). The greater the negative pressure differential (formation pressure to wellbore pressure) the easier it is for formation fluids to enter the wellbore, especially if this is coupled with high permeability and porosity. Finally, gas will flow into the wellbore much faster than oil or water

2. WELL CONTROL PRINCIPLES

There are basically two ways in which fluids can be prevented from flowing, from the formation, into the borehole:

Primary Control

Primary control over the well is maintained by ensuring that the pressure due to the colom of mud in the borehole is greater than the pressure in the formations being drilled i.e. maintaining a positive differential pressure or **overbalance** on the formation pressures. (Figure 1)

Secondary Control

Secondary control is required when primary control has failed (e.g. an unexpectedly high pressure formation has been entered) and formation fluids are flowing into the wellbore. The aim of secondary control is to stop the flow of fluids into the wellbore and eventually allow the influx to be circulated to surface and safely discharged, while preventing further influx downhole. The first step in this process is to close the annulus space off at surface, with the BOP valves, to prevent further influx of formation fluids (Figure 2). The next step is to circulate heavy mud down the drillstring and up the annulus, to displace the influx and replace the original mud (which allowed the influx in the first place). The second step will require flow the annulus but this is done in a controlled way so that no further influx occurs at the bottom of the borehole. The heavier mud should prevent a further influx of formation fluid when drilling ahead. The well will now be back under primary control.

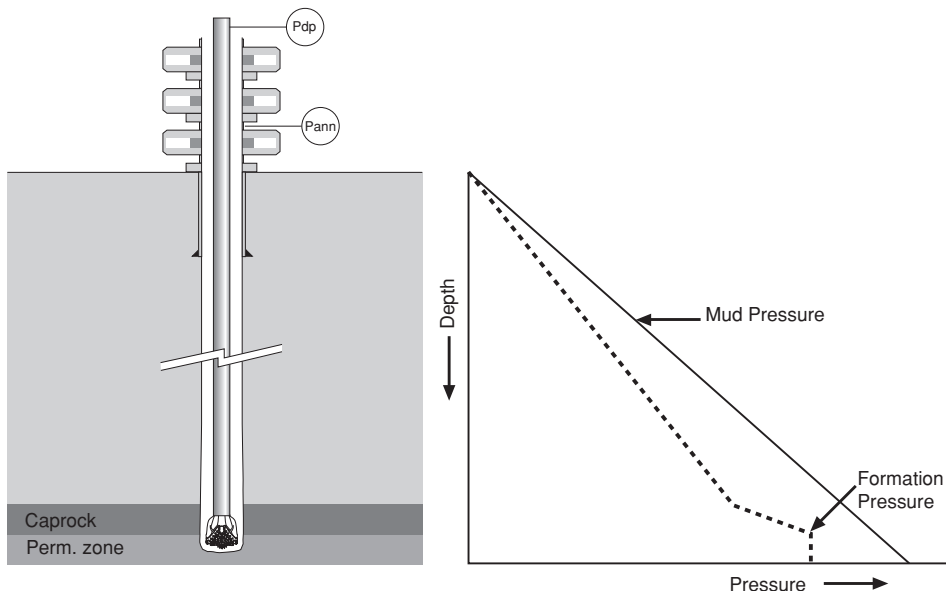

Figure 1 Primary Control - Pressure due to mud colom exceeds Pore Pressure

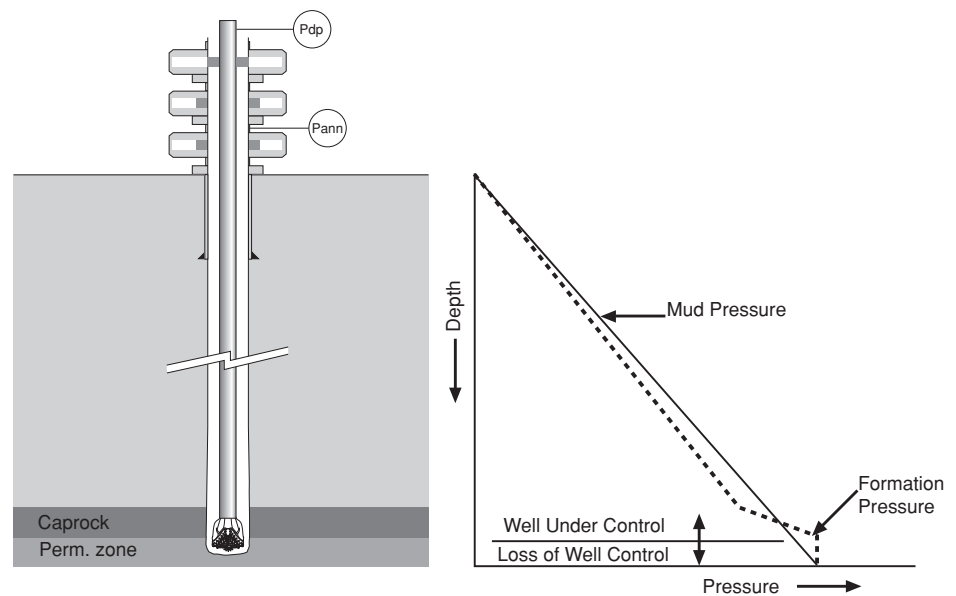

Figure 2 Secondary Control -Influx Controlled by Closing BOP's

Primary control of the well may be lost (i.e. the borehole pressure becomes less than the formation pressure) in two ways. The first is if the formation pressure in a zone which is penetrated is higher than that predicted by the reservoir engineers or geologist. In this case the drilling engineer would have programmed a mud weight that was too low and therefore the bottomhole pressure would be less than the formation pressure (Figure 1). The second is if the pressure due to the column of mud decreases for some reason, and the bottomhole pressure drops below the formation pressure. Since the bottomhole pressure is a product of the mud density and the height of the column of mud. The pressure at the bottom of the borehole can therefore only decrease if either the mud density or the height of the column of mud decreases (Figures 3 and 4).

There are a number of ways in which the density of the mud (mudweight) and/or the height of the column of mud can fall during normal drilling operations.

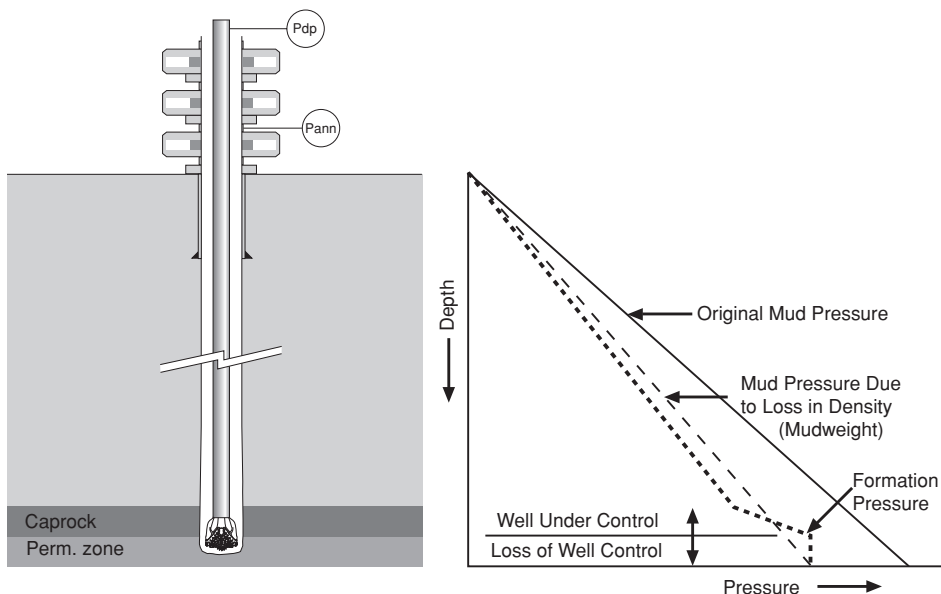

Figure 3 Loss of Primary Control - Due to Reduction in Mudweight

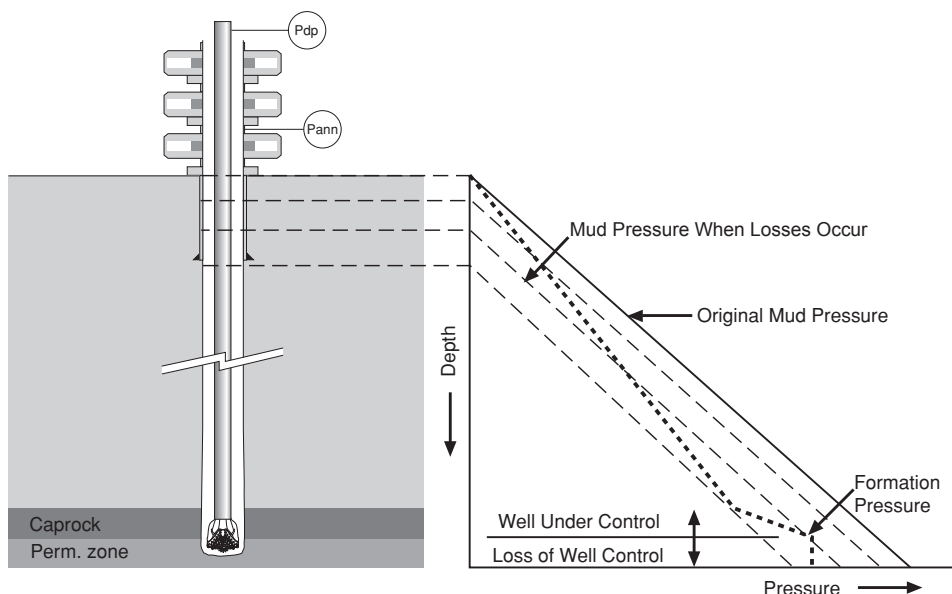

Figure 4 Loss of Primary Control - Due to Reduction in fluid level in borehole

2.1 Reduction in Mudweight

The mudweight is generally designed such that the borehole pressure opposite permeable (and in particular hydrocarbon bearing sands) is around 200-300 psi greater than the formation pore pressure. This pressure differential is known as the **overbalance**. If the mud weight is reduced the overbalance becomes less and the risk of taking a kick becomes greater. It is therefore essential that the mudweight is continuously monitored to ensure that the mud that is being pumped into the well

is the correct density. If the mudweight does fall for some reason then it must be increased to the programmed value before it is pumped downhole.

The mudweight will fall during normal operations because of the following:

- Solids removal
- Excessive dilution of the mud (due to watering-back)
- Gas cutting of the mud.

a. Solids removal :

The drilled cuttings must be removed from the mud when the mud returns to surface. If the solids removal equipment is not designed properly a large amount of the weighting solids (**Barite**) may also be removed. The solids removal equipment must be designed such that it removes only the drilled cuttings. If Barite is removed by the solids removal equipment then it must be replaced before the mud is circulated downhole again.

b. Dilution :

When the mud is being treated to improve some property (e.g. viscosity) the first stage is to dilute the mud with water (**water-back**) in order to lower the percentage of solids. Water may also be added when drilling deep wells, where evaporation may be significant. During these operations mud weight must be monitored and adjusted carefully.

c. Gas cutting :

If gas seeps from the formation into the circulating mud (known as **gas-cutting**) it will reduce the density of the drilling fluid. When this occurs, the mudweight measured at surface can be quite alarming. It should be appreciated however that the gas will expand as it rises up the annulus and that the reduction in borehole pressure and therefore the reduction in overbalance is not as great as indicated by the mudweight measured at surface. Although the mud weight may be drastically reduced at surface, the effect on the bottom hole pressure is not so great. This is due to the fact that most of the gas expansion occurs near the surface and the product of the mudweight measured at surface and the depth of the borehole will not give the true pressure at the bottom of the hole. For example, if a mud with a density of 0.530 psi/ft. were to be contaminated with gas, such that the density of the mud at surface is 50% of the original mud weight (i.e. measured as 0.265 psi/ft.) then the borehole pressure at 10,000ft would normally be calculated to be only 2650 psi. However, it can be seen from Figure 5 that the decrease in bottom hole pressure at 10,000 ft. is only 40-45 psi.

It should be noted however that the presence of gas in the annulus still poses a problem, which will get worse if the gas is not removed. The amount of gas in the mud should be monitored continuously by the mudloggers, and any significant increase reported immediately.

2.2 Reduced Height of Mud Column

During normal drilling operations the volume of fluid pumped into the borehole should be equal to the volume of mud returned and when the pumps are stopped the fluid should neither continue to flow from the well (this would indicate that a kick

was taking place) nor should the level of the mud fall below the mud flowline. The latter can be observed by looking down the hole through the rotary table.

If the top of the mud drops down the hole then the height of the column of mud above any particular formation is decreased and the borehole pressure at that point is decreased. It is therefore essential that the height of the column of mud is continuously monitored and that if the column of mud does not extend to surface then some action must be taken before continuing operations.

The mud column height may be reduced by ;

- Tripping
- Swabbing
- Lost circulation

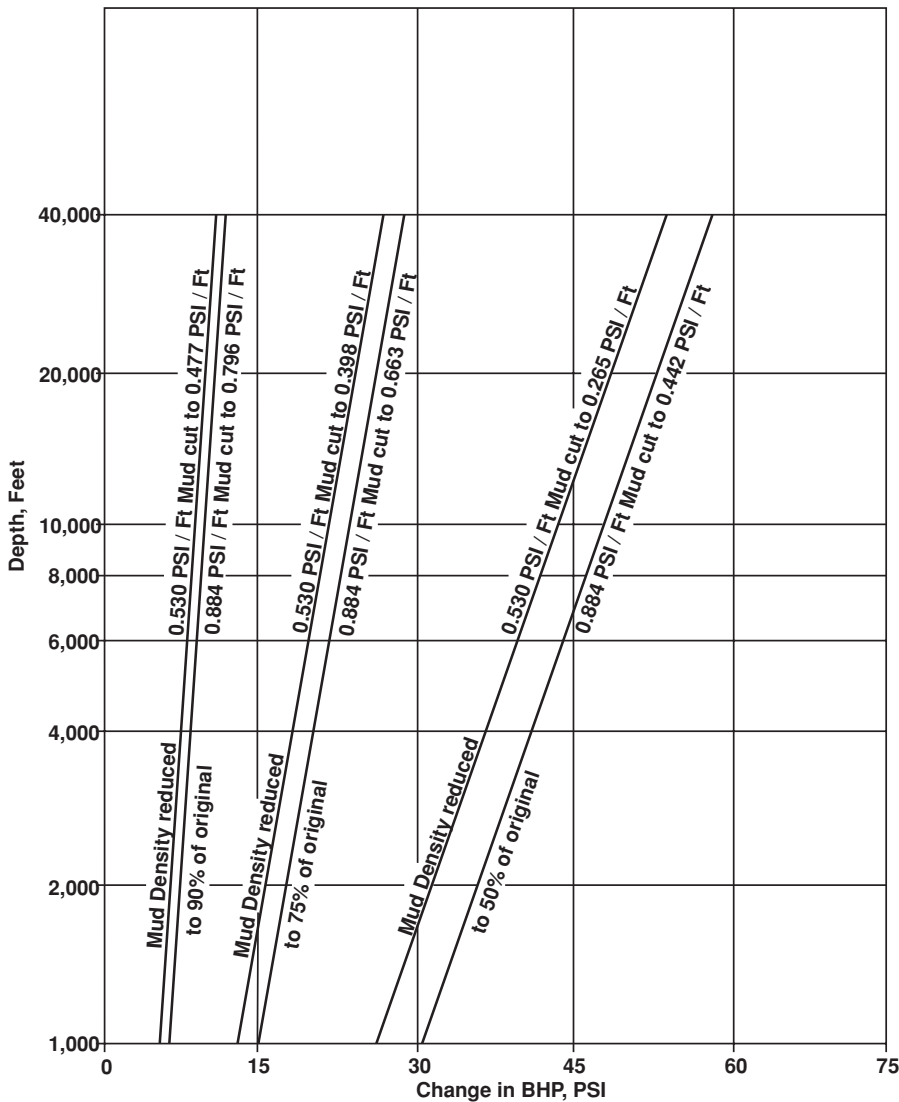

Figure 5 Reduction in bottom hole pressure due to observed surface reduction caused by gas influx

a. Tripping :

The top of the column of mud will fall as the drillpipe is pulled from the borehole when tripping. This will result in a reduction in the height of the column of mud above any point in the wellbore and will result in a reduction in bottom hole pressure. The hole must therefore be filled up when pulling out of the hole. The volume of pipe removed from the borehole must be replaced by an equivalent volume of drilling fluid.

b. Swabbing :

Swabbing is the process by which fluids are sucked into the borehole, from the formation, when the drillstring is being pulled out of hole. This happens when the bit has become covered in drilled material and the drillstring acts like a giant piston when moving upwards. This creates a region of low pressure below the bit and formation fluids are sucked into the borehole. (The opposite effect is known as **Surging**, when the pipe is run into the hole).

The amount of swabbing will increase with:

- The adhesion of mud to the drillpipe
- The speed at which the pipe is pulled
- Use of muds with high gel strength and viscosity
- Having small clearances between drillstring and wellbore
- A thick mud cake
- Inefficient cleaning of the bit to remove cuttings.

c. Lost Circulation :

Lost circulation occurs when a fractured, or very high permeability, formation is being drilled. Whole mud is lost to the formation and this reduces the height of the mud column in the borehole. Lost circulation can also occur if too high a mud weight is used and the formation fracture gradient is exceeded. Whatever the cause of lost circulation it does reduce the height of the column of mud in the wellbore and therefore the pressure at the bottom of the borehole. When the borehole pressure has been reduced by losses an influx, from an exposed, higher pressure, formation can occur. Losses of fluid to the formation can be minimised by :

- Using the lowest practicable mud weight.
- Reducing the pressure drops in the circulating system therefore reducing the ECD of the mud
- Avoid pressure surges when running pipe in the hole.
- Avoid small annular clearances between drillstring and the hole.

It is most difficult to detect when losses occur during tripping pipe into or out of the hole since the drillpipe is being pulled or run into the hole and therefore the level of the top of the mud column will move up and down. A **Possum Belly Tank** (or trip tank) with a small diameter to height ratio is therefore used to measure the amount of mud that is used to fill, or is returned from, the hole when the pipe is pulled from, or run into, the hole respectively. As the pipe is pulled from the hole, mud from the trip tank is allowed to fill the hole as needed. Likewise when tripping in, the displaced mud can be measured in the trip tank (Figure 6). The advantage of using a tank with a small diameter to height ratio is that it allows accurate measurements of relatively small volumes of mud.

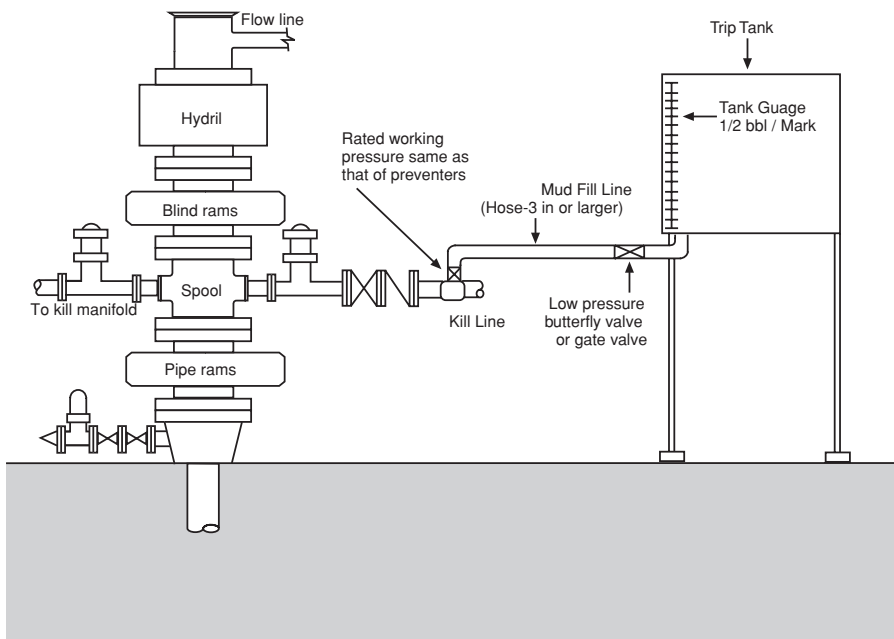

Figure 6 Trip tank connected to BOP stack to closely monitor volume of mud required for fill-up

When the drillpipe is pulled out the hole the volume of mud that must be pumped into the hole can be calculated from the following :

Length of Pipe x Displacement of Pipe

10 stands of 5", 19.5 lb/ft drillpipe would have a displacement of :
 $10 \times 93 \times 0.00734 \text{ bbl/ft.} = 6.8 \text{ bbls.}$

Therefore, the mud level in the hole should fall by an amount equivalent to 6.8bbls of mud. If this volume of mud is not required to fill up the hole when 10 stands have been pulled from the hole then some other fluid must have entered the wellbore. This is a primary indicator of a kick.

Exercise 1 Impact of Mudweight and Hole Fillup on Bottomhole Pressure:

- a. An 8 1/2" hole is drilled to 8000ft using mud with a density of 12 ppg. If the formation pore pressure at this depth was 4700 psi what would be the mud pressure overbalance, above the pore pressure.
- b. If the mud density were 10 ppg what would be the overbalance?
- c. If the fluid level in the annulus in a. above dropped to 200 ft due to inadequate hole fill up during tripping, what would be the effect on bottom hole pressure?

3. WARNING INDICATORS OF A KICK

If a kick occurs, and is not detected, a blowout may develop. The drilling crew must therefore be alert and know the warning signs that indicate that an influx has occurred at the bottom of the borehole. Since the influx is occurring at the bottom of the hole the drilling crew relies upon indications at surface that something is happening downhole. Although these signs may not all positively identify a kick, they do provide a warning and should be monitored carefully. Some of the indicators that the driller sees at surface can be due to events other than an influx and the signs are therefore not conclusive. For example, an increase in the rate of penetration of the bit can occur because the bit has entered an overpressured formation or it may occur because the bit has simply entered a new formation which was not predicted by the geologist. However, all of the following indicators should be monitored and if any of these signs are identified they should be acted upon. Some of these indicators are more definite than others and are therefore called **primary indicators**. **Secondary indicators** those that are not conclusive and may be due to something else.

3.1 Primary Indicators of a Kick

The primary indicators of a kick are as follows:

- Flow rate increase
- Pit volume increase
- Flowing well with pumps shut off
- Improper hole fillup during trips

a. Flow rate increase :

While the mud pumps are circulating at a constant rate, the rate of flow out of the well, Q_{out} should be equal to the rate of flow into the well, Q_{in} . If Q_{out} increases (without changing the pump speed) this is a sign that formation fluids are flowing into the wellbore and pushing the contents of the annulus to the surface. The flowrate into and out of the well is therefore monitored continuously using a differential flowmeter. The meter measures the difference in the rate at which fluid is being pumped into the well and the rate at which it returns from the annulus along the flowline.

b. Pit volume increase :

If the rate of flow of fluid into and out of the well is constant then the volume of fluid in the mud pits should remain approximately (allowing for hole deepening etc.) constant. A rise in the level of mud in the active mudpits is therefore a sign that some other fluid has entered the system (e.g. an influx of formation fluids). The level of the mud in the mudpits is therefore monitored continuously. The increase in volume in the mud pits is equal to the volume of the influx and should be noted for use in later calculations.

c. Flowing well with pumps shut off :

When the rig pumps are not operating there should be no returns from the well. If the pumps are shut down and the well continues to flow, then the fluid is being pushed out of the annulus by some other force. It is assumed in this case that the formation pressure is higher than the hydrostatic pressure due to the column of mud and therefore that an influx of fluid is taking place. There are 2 other possible explanations for this event:



-
- The mud in the borehole will expand as it heats up. This expansion will result in a small amount of flow when the pumps are shut off.
 - If a small amount of heavy mud has accidentally been pumped into the drillstring and the mud in the annulus is being displaced by a U-tubing effect

d. Improper Hole Fill-Up During Trips

As mentioned earlier, the wellbore should to be filled up with mud when pipe is pulled from the well. If the wellbore overflows when the volume of fluid, calculated on the basis of the volume of drillpipe removed from the well, is pumped into the well then fluids from the formation may have entered the well.

3.2 Secondary Indicators

The most common secondary indicators that an influx has occurred are:

- Drilling break
- Gascut mud
- Changes in pump pressure

a. Drilling Break

A **drilling break** is an abrupt increase in the rate of penetration and should be treated with caution. The drilling break may indicate that a higher pressure formation has been entered and therefore the chip hold down effect has been reduced and/or that a higher porosity formation (e.g. due to under-compaction and therefore indicative of high pressures) has been entered. However an increase in drilling rate may also be simply due to a change from one formation type to another.

Experience has shown that drilling breaks are often associated with overpressured zones. It is recommended that a flow check is carried whenever a drilling break occurs.

b. Gas Cut Mud

When gas enters the mud from the formations being drilled, the mud is said to be **gascut**. It is almost impossible to prevent any gas entering the mud column but when it does occur it should be considered as an early warning sign of a possible influx. The mud should be continuously monitored and any significant rise above low background levels of gas should be reported. Gas cutting may occur due to:

- Drilling in a gas bearing formation with the correct mud weight
- Swabbing when making a connection or during trips
- Influx due to a negative pressure differential (formation pressure greater than borehole pressure).

The detection of gas in the mud does not necessarily mean the mudweight should be increased. The cause of the gas cutting should be investigated before action is taken.

c. Changes in Pump Pressure

If an influx enters the wellbore the (generally) lower viscosity and lower density formation fluids will require much lower pump pressures to circulate them up the annulus. This will cause a gradual drop in the pressure required to circulate the

drilling fluid around the system. In addition, as the fluid in the annulus becomes lighter the mud in the drillpipe will tend to fall and the pump speed (strokes per min.) will increase. Notice, however, that these effects can be caused by other drilling problems (e.g. washout in drillstring, or twist-off).

3.3 Precautions Whilst Drilling

Whilst drilling, the drilling crew will be watching for the indicators described above. If one of the indicators are seen then an operation known as a **flow check** is carried out to confirm whether an influx is taking place or not. The procedure for conducting a flowcheck is as follows:

- (i) Pick up the Kelly until a tool joint appears above the rotary table
- (ii) Shut down the mud pumps
- (iii) Set the slips to support the drillstring
- (iv) Observe flowline and check for flow from the annulus
- (v) If the well is flowing, close the BOP. If the well is not flowing resume drilling, checking for further indications of a kick.

3.4 Precautions During Tripping

Since most blow-outs actually occur during trips, extra care must be taken during tripping. Before tripping out of the hole the following precautions are recommended:

- (i) Circulate bottoms up to ensure that no influx has entered the wellbore
- (ii) Make a flowcheck
- (iii) Displace a heavy slug of mud down the drillstring. This is to prevent the string being pulled wet (i.e. mud still in the pipe when the connections are broken). The loss of this mud complicates the calculation of drillstring displacement.

It is important to check that an influx is not taking place and that the well is **dead** before pulling out of the hole since the well control operations become more complicated if a kick occurs during a trip. When the bit is off bottom it is not possible to circulate mud all the way to the bottom of the well. If this happens the pipe must be run back to bottom with the BOP's closed. This procedure is known as **stripping-in** and will be discussed later.

As the pipe is tripped out of the hole the volume of mud added to the well, from the trip tank, should be monitored closely. To check for swabbing it is recommended that the drillbit is only pulled back to the previous casing shoe and then run back to bottom before pulling out of hole completely. This is known as a **short trip**. Early detection of swabbing or incomplete filling of the hole is very important.

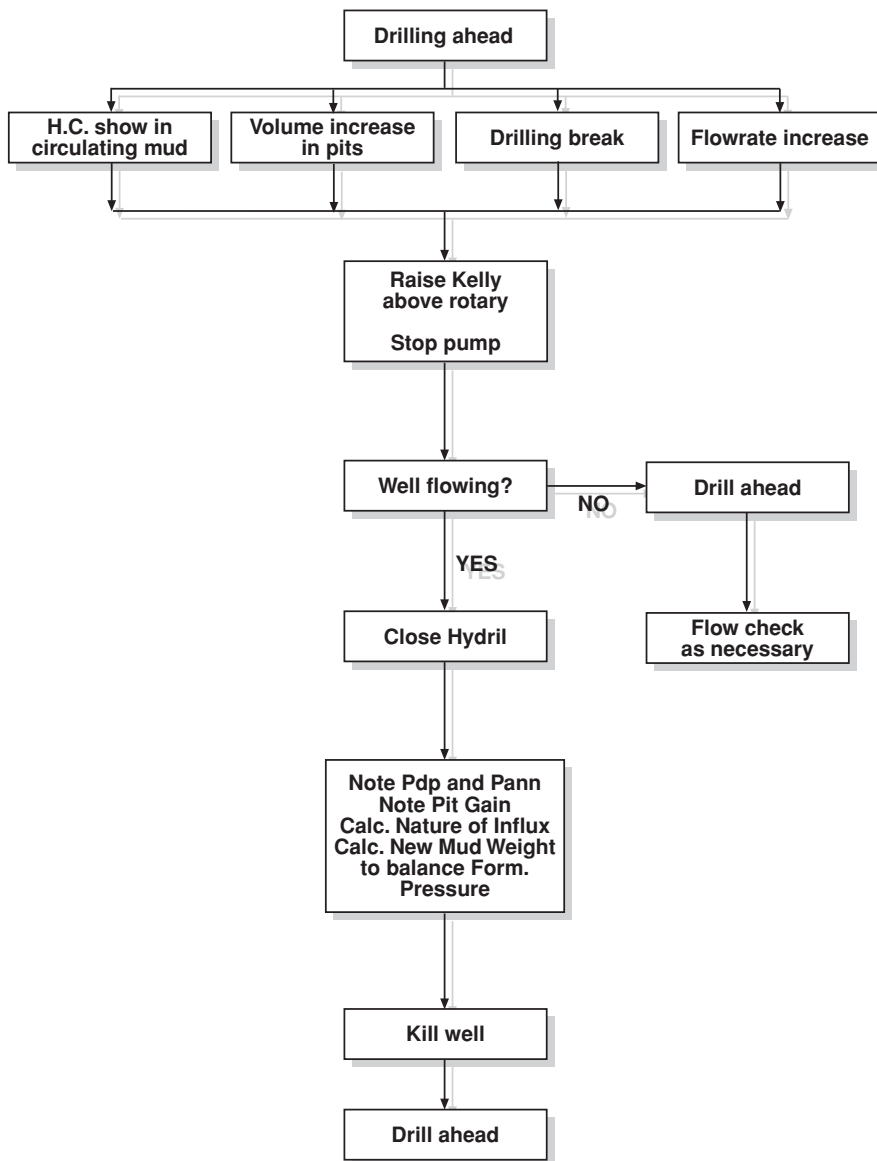

Figure 7 Operational Procedure following detection of a kick

Exercise 2 Response to a kick

Whilst drilling the 8 1/2" hole of the well the mud pit level indicators suggest that the well is flowing.

- a. What action should the driller take?
- b. What action should the driller take if he was pulling out of hole at the time that the kick was recognised?
- c. What other indicators of a kick would the driller check for?

When considering the above, also consider the sequence of operations and the possible misinterpretations of the indicators.

4. SECONDARY CONTROL

If a kick is detected and a pit gain has occurred on surface, it is clear that primary control over the well has been lost and all normal drilling or tripping operations must cease in order to concentrate on bringing the well back under primary control.

The first step to take when primary control has been lost is to close the BOP valves, and seal off the drillstring to wellhead annulus at the surface. This is known as initiating **secondary control** over the well. It is not necessary to close off valves inside the drillpipe since the drillpipe is connected to the mudpumps and therefore the pressure on the drillpipe can be controlled.

Usually it is only necessary to close the uppermost annular preventer - the **Hydril**, but the lower **pipe rams** can also be used as a back up if required (Figure 7). When the well is shut in, the choke should be fully open and then closed slowly so as to prevent sudden pressure surges. The surface pressure on the drillpipe and the annulus should then be monitored carefully. These pressures can be used to identify the nature of the influx and calculate the mud weight required to kill the well.

4.1 Shut in Procedure

The following procedures should be undertaken when a kick is detected. This procedure refers to fixed drilling rigs (land rigs, jack ups, rigs on fixed platforms). Special procedures for floating rigs will be given later.

For a kick detected while drilling:

- (i) Raise kelly above the rotary table until a tool joint appears
- (ii) Stop the mud pumps
- (iii) Close the annular preventer
- (iv) Read shut in drill pipe pressure, annulus pressure and pit gain.

Before closing in the annular preventer the choke line must be opened to prevent surging effects on the openhole formations (water hammer). The choke is then slowly closed when the annular preventer is closed. Once the well is closed in it may take some time for the drill pipe pressure to stabilise, depending on formation permeability.

When a kick is detected while tripping:

- (i) Set the top tool joint on slips
- (ii) Install a safety valve (open) on top of the string
- (iii) Close the safety valve and the annular preventer
- (iv) Make up the kelly
- (v) Open the safety valve
- (vi) Read the shut in pressures and the **pit gain** (increase in volume of mud in the mud pits).

The time taken from detecting the kick to shutting in the well should be about 2 minutes. Regular kick drills should be carried out to improve the rig crew's reaction time.

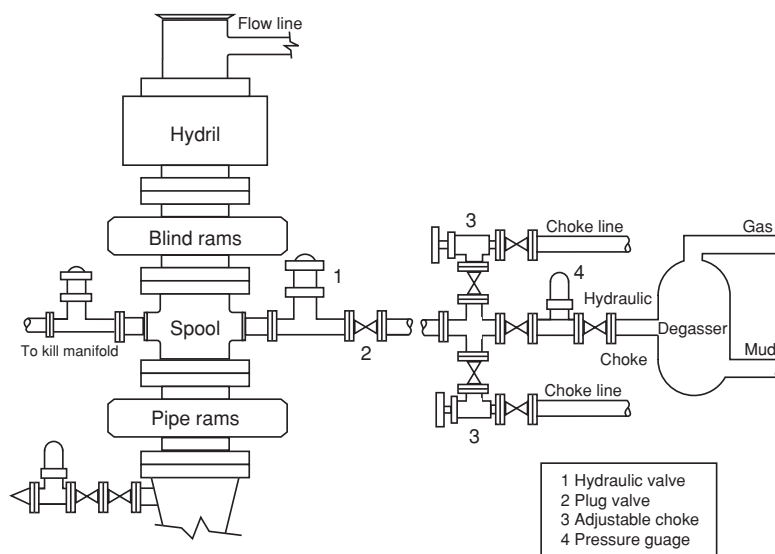

Figure 8 BOP stack and choke manifold

4.2 Interpretation of Shut-in Pressures

When an influx has occurred and has subsequently been shut-in, the pressures on the drillpipe and the annulus at surface can be used to determine:

- The formation pore pressure
- The mudweight required to kill the well
- The type of influx

In order to determine the formation pressure, the kill mudweight and the type of influx the distribution of pressures in the system must be clearly understood. When the well is shut-in the pressure at the top of the drillstring (the **drillpipe pressure**) and in the annulus (the **annulus pressure**) will rise until:

- (i) The drillpipe pressure plus the hydrostatic pressure due to the fluids in the drillpipe is equal to the pressure in the formation and,
- (ii) The annulus pressure plus the hydrostatic pressure due to the fluids in the annulus is equal to the pressure in the formation.

It should be clearly understood however that the drillpipe and annulus pressure will be different since, when the influx occurs and the well is shut-in, the drillpipe will contain drilling fluid but the annulus will now contain both drilling fluid and the fluid (oil, gas or water) which has flowed into the well. Hence the hydrostatic pressure of the fluids in the drillstring and the annulus will be different. A critical assumption that is made in these calculations is that the influx travels up the annulus between the drillstring and the borehole rather than up the inside of the drillstring. This is considered to be a reasonable assumption since the influx would be expected to follow the flow of fluids through the system when they enter the wellbore.

It is convenient to analyse the shut-in pressures by comparing the situation with that in a U-tube (Figure 9). One arm of the U-tube represents the inner bore of the drillstring, while the other represents the annulus. A change of pressure in one arm will affect the pressure in the other arm so as to restore equilibrium.

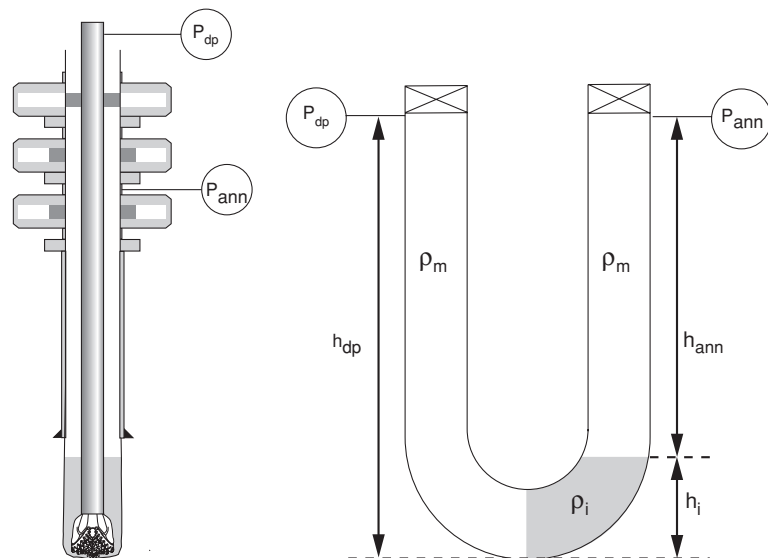

Figure 9 Interpretation of wellbore pressures as a U-Tube

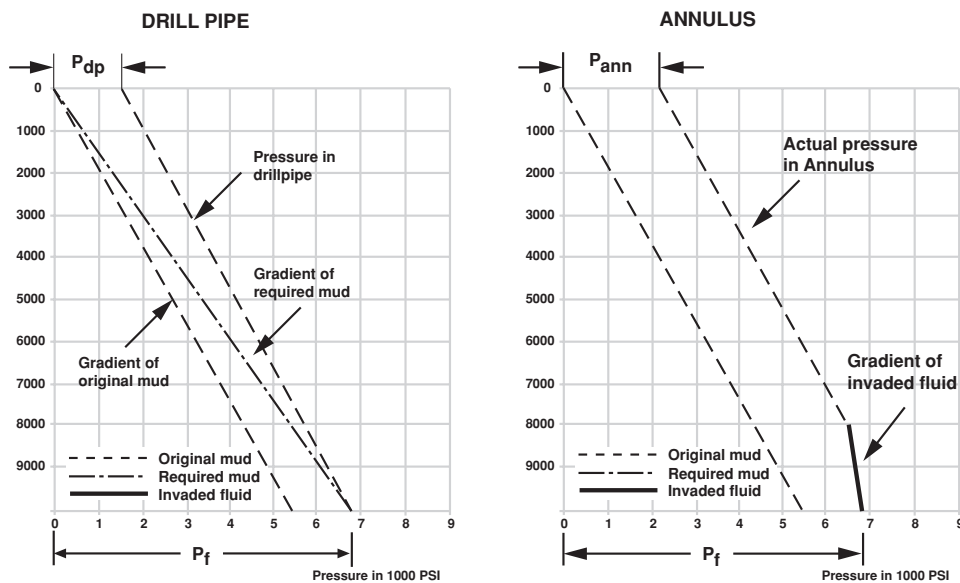

Figure 10 Pressure profile in drillpipe and annulus when well shut-in

The pressure at the bottom of the drillstring is due to the hydrostatic head of mud, while in the annulus the pressure is due to a combination of mud and the formation fluid influx (Figure 10). Hence, when the system is in equilibrium, the bottom hole pressure will be equal to the drill pipe shut-in pressure plus the hydrostatic pressure exerted by the drilling mud in the drillstring. Hence:

$$P_{dp} + \rho_m d = P_{bh}$$

Equation 1

where,

- P_{dp} = shut in drillpipe pressure (psi)
- ρ_m = mud pressure gradient (psi/ft)
- d = vertical height of mud column (ft)
- P_{bh} = bottomhole pressure (psi)

If the well is in equilibrium and there is no increase in the surface pressures the bottomhole pressure must be equal to the formation pore pressure :

$$P_{bh} = P_f$$

Equation 2

Since the mudweight in the drill pipe will be known throughout the well killing operation and P_{dp} can be used as a direct indication of bottom hole pressure (i.e. the drillpipe pressure gauge acts as a bottom hole pressure gauge). No further influx of formation fluids must be allowed during the well killing operation. In order to accomplish this the bottom hole pressure, $P_{bh} (= P_{dp} + \rho_m d)$ must be kept equal to,

or slightly above, the formation pressure, P_f . This is an important concept of well control and the one on which everything else is based. This is the reason that this technique for well killing is sometimes referred to as the **constant bottom hole pressure killing methods**.

On the annulus arm of the U-tube, the bottom hole pressure is equal to the surface annulus pressure and the combined hydrostatic pressure of the mud and influx:

$$P_{\text{ann}} + h_i \rho_i + (d-h_i) \rho_m = P_{\text{bh}}$$

Equation 3

where,

P_{ann} = shut-in annulus pressure (psi)

h_i = height of influx (ft)

ρ_i = pressure gradient of influx (psi/ft)

and to achieve equilibrium :

$$P_{\text{bh}} = P_f$$

Equation 4

One further piece of information can be inferred from the events observed at surface when the well has been shut-in. The vertical height of the influx (h_i) can be calculated from the displaced volume of mud measured at surface (i.e. the pit gain) and the cross-sectional area of the annulus.

$$h_i = \frac{V}{A}$$

Equation 5

where,

V = pit gain (bbls)

A = cross section area (bbls/ft)

Both V and A (if open hole) will not be known exactly, so h_i can only be taken as an estimate.

4.3 Formation Pore Pressure

Since an influx has occurred it is obvious that the hydrostatic pressure of the mud column was not sufficient to overbalance the pore pressure in the formation which has been entered. The pressure in this formation can however be calculated from Equation 1:

$$P_f = P_{\text{bh}} = P_{\text{dp}} + \rho_m d$$

Equation 6



Since all of the parameters on the right hand side of this equation are known, the formation pressure can be calculated.

4.4 Kill Mud Weight

The mudweight required to kill the well and provide overbalance whilst drilling ahead can be calculated from Equation 1:

$$P_{bh} = P_{dp} + \rho_m d$$

The new mud weight must be sufficient to balance or be slightly greater than (i.e. include an overbalance of about 200 psi) the bottom hole pressure. Care must be taken not to weight up the mud above the formation fracture gradient. If an overbalance is used the equation becomes:

$$\rho_k d = P_{bh} + P_{ob}$$

$$\rho_k d = P_{dp} + \rho_m d + P_{db}$$

Equation 7

or

$$\rho_k = \rho_m + \frac{(P_{dp} + P_{ob})}{d}$$

where,

ρ_k = kill mudweight (psi/ft)

P_{ob} = overbalance (psi)

Notice that the volume of pit gain (V) and the casing pressure (P_{ann}) do not appear in this equation, and so have no influence on the kill mud weight.

4.5 Determination of the Type of Influx

By combining equations 1,2 and 3 the influx gradient, ρ_i can be found from:

$$\rho_i = \rho_m - \frac{(P_{ann} - P_{dp})}{h_i}$$

Equation 8

(Note: The expression is given in this form since $P_{ann} > P_{dp}$, due to the lighter fluid being in the annulus)

From the gradient calculated from equation 3 the type of fluid can be identified as follows:

Gas	0.075 - 0.150 psi/ft
Oil	0.3 - 0.4 psi/ft
Seawater	0.470 - 0.520 psi/ft

If ρ_i was found to be about 0.25 this may indicate a mixture of gas and oil. If the nature of the influx is not known it is usually assumed to be gas, since this is the most severe type of kick.

PREPARED BY.....

WELL CONTROL KICK SHEET

<p>A PRE-RECORDED DATA :</p> <p>DATE _____ TIME OF KICK _____</p> <p>MEASURED DEPTH _____ FT</p> <p>TRUE VERTICAL DEPTH _____ FT</p> <p>LAST CASING SHOE _____ FT</p> <p>MAXIMUM ALLOWABLE SURFACE PRESSURE _____ PSI</p> <p>PUMP OUTPUT/SLOW PUMP RATES/PRESSURE</p> <p>PUMP 1 _____ SPM _____ BBL/MIN _____ PSI</p> <p> _____ SPM _____ BBL/MIN _____ PSI</p> <p>PUMP 2 _____ SPM _____ BBL/MIN _____ PSI</p> <p> _____ SPM _____ BBL/MIN _____ PSI</p> <p>FLOATERS:CHOKE LINE FRICTION = _____ PSI</p>	<p>D CALCULATE : KILL WEIGHT MUD:</p> <p>1 SIDPP x 20 = (_____) x 20 = _____ PPG</p> <p> DEPTH (TVD) = (_____)</p> <p>2 SAFETY OR TRIP MARGIN (WHEN NEEDED) = _____ PPG</p> <p>3 ORIGINAL MUD WEIGHT = _____ PPG</p> <p>4 KILL WEIGHT MUD (1+2+3) = _____ PPG</p>
<p>B KICK DATA:</p> <p>SHUT IN DRILLPIPE PRSSURE _____ PSI</p> <p>SHUT IN CASING PRSSURE _____ PSI</p> <p>PIT VOLUME INCREASE _____ PSI</p>	<p>E CALCULATE : FINAL CIRCULATING PRESSURE:</p> <p>FCP = (SLOW PUMP PRESSURE) x $\frac{\text{(NEW MUD WEIGHT)}}{\text{(ORIGINAL MUD WEIGHT)}}$ = _____ PSI</p> <p>FCP = (_____) x $\left(\frac{\text{_____}}{\text{_____}} \right)$ = _____ PSI</p>
<p>C CALCULATE : INITIAL CIRCULATING PRESSURE :</p> <p>1 SLOW PUMP RATE AT _____ SPM = _____ PSI</p> <p>2 SHUT IN DRILL PIPE PRESSURE = _____ PSI</p> <p>3 INITIAL CIRCULATING PRESSURE (1+2) = _____ PSI</p>	<p>F CALCULATE : CAPACITIES AND VOLUMES</p> <p>1 DRILLSTRING CAPACITY _____ BBLs</p> <p>2 ANNULAR VOLUME OF OPEN HOLE _____ BBLs</p> <p>3 ANNULAR VOLUME OF CASING _____ BBLs</p> <p>4 ACTIVE SURFACE VOLUME _____ BBLs</p> <p>5 TOTAL ACTIVE SYSTEM VOLUME (1+2+3+4) _____ BBLs</p>

G CALCULATE : PUMPING TIME AND STROKES

1 SURFACE TO BIT TRAVEL TIME	= $\frac{\text{DRILL STRING CAPACITY}}{\text{PUMP OUTPUT (BBL/MIN)}}$	= $\frac{\text{BBLs}}{\text{BBLs/MIN}}$	= _____ MIN X _____ SPM	= _____ STKS TO FIL??? DRILLSTRING
2 SURFACE TO BIT TRAVEL TIME	= $\frac{\text{ANNULAR VOLUME OPEN HOLE}}{\text{PUMP OUTPUT (BBL/MIN)}}$	= $\frac{\text{BBLs}}{\text{BBLs/MIN}}$	= _____ MIN X _____ SPM	= _____ STKS TO SHOE
3 SURFACE TO BIT TRAVEL TIME	= $\frac{\text{ANNULAR VOLUME OF CASING}}{\text{PUMP OUTPUT (BBL/MIN)}}$	= $\frac{\text{BBLs}}{\text{BBLs/MIN}}$	= _____ MIN X _____ SPM	= _____ STKS TO FIL??? CASING
4 TOTAL MINUTES TO KILL WELL (1+2+3)	_____ TOTAL MIN			
4 TOTAL STROKES TO KILL WELL (1+2+3)				_____ TOTAL STKS

H DRILLPIPE GRAPH — SURFACE TO BIT TRAVEL TIME

- 1 PLOT INITIAL CIRCULATING PRESSURE AT LEFT OF GRAPH
- 2 PLOT FINAL CIRCULATING PRESSURE AT RIGHT OF GRAPH
- 3 CONNECT POINTS WITH A STRAIGHT LINE
- 4 ACROSS THE BOTTOM OF GRAPH WRITE: (A) TIME, SURFACE TO BIT (B) SURFACE TO BIT STROKES AND (C) PRESSURES

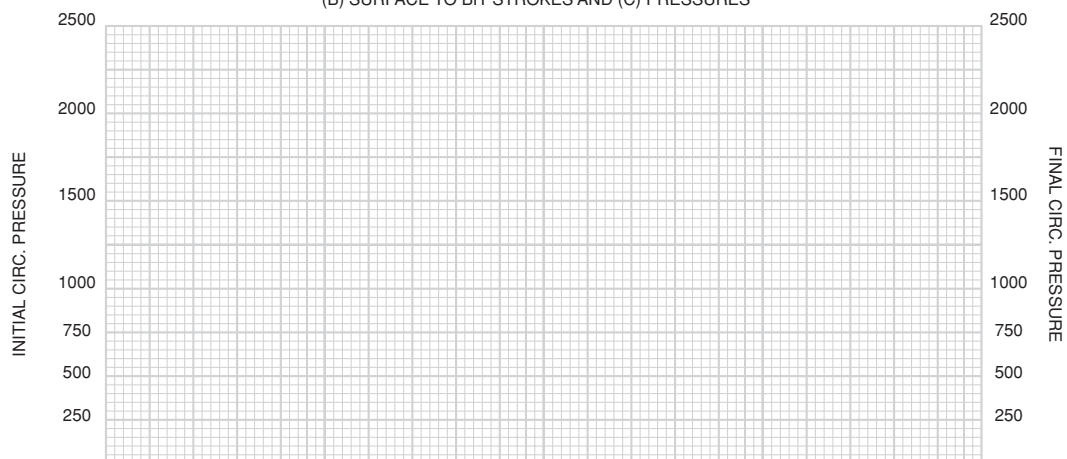

A	TIME	
B	STKS	
C	PRESS	

Figure 11 Well Control "Kill Sheet"



Exercise 3 Killing Operation Calculations

Whilst drilling the 8 1/2" hole section of a well the mud pit level indicators indicate that the well is flowing. When the well is made safe the following information is collected :

drillpipe pressure = 100 psi
casing pressure = 110 psi
pit gain = 10 bbls

Using this and the information provided in attachment 1 carry out the necessary calculations to determine:

- the formation pressure and kill mudweight
- the type of influx
- the time to kill the well
- the time to the end of stage 1, 2, and 3 of the killing operation
- the pump pressure during stages 2, 3, and 4 of the operation

In addition to the above, complete the "kill sheet" in Figure 10 and confirm that the results from the above correspond to the results calculated above.

4.6 Factors Affecting the Annulus Pressure, P_{ann}

4.6.1 Size of Influx:

As stated earlier, the time taken to close in the well should be no more than 2 minutes. If the kick is not recognised quickly enough, or there is some delay in closing in the well, the influx continues to flow into the annulus. The effect of this is shown in Figure 12. As the volume of the influx allowed into the annulus increases the height of the influx increases and the higher the pressure on the annulus, P_{ann} when the well is eventually shut-in.

Not only will the eventual pressure at surface increase but as can be seen from Figure 13, the pressure along the entire wellbore increases. There are two dangers here:

- At some point the fracture pressure of one of the formations in the openhole section may be exceeded. This may lead to an underground blow-out - formation fluid entering the wellbore and then leaving the wellbore at some shallower depth (Figure 13).

Once a formation has been fractured it may be impossible to weight the mud up to control the flowing formation and there will be continuous crossflow between the zones. If an underground blow-out occurs at a shallow depth it may cause **cratering** (breakdown of surface sediment, forming a large hole into which the rig may collapse).

- there is the possibility that P_{ann} will exceed the **burst capacity** of the casing at surface.

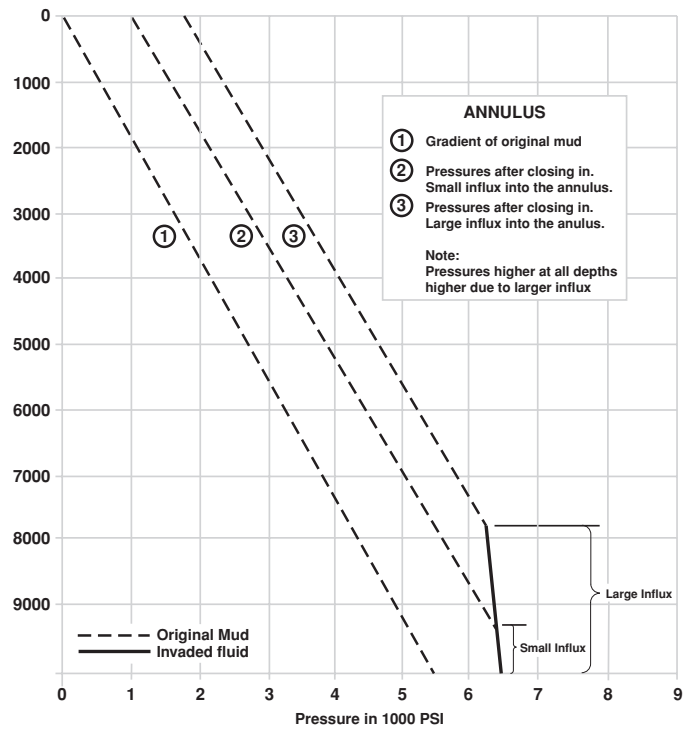

Figure 12 Effect of increasing influx before the well is shut in

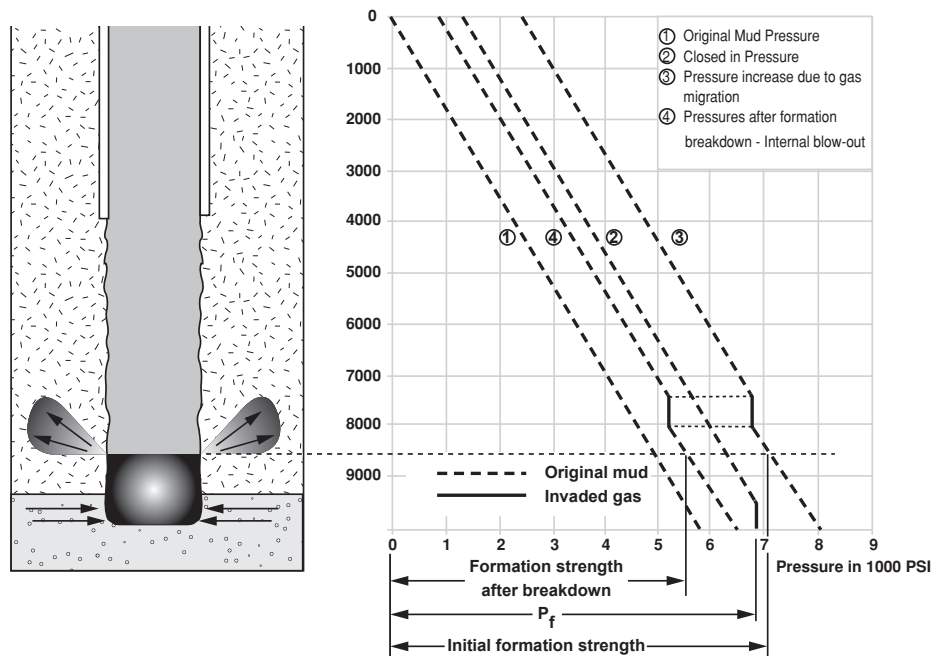

Figure 13 Underground blow-out conditions

4.6.2 Gas Buoyancy Effect

An influx of gas into the wellbore can have a significant effect on the annulus pressure.

Since there is such a large difference in density between the gas and the mud a gas bubble entering the well will be subjected to a large buoyancy effect. The gas bubble will therefore rise up the annulus. As the gas rises it will expand and, if the well is open, displace mud from the annulus. If, however, the well is shut in mud cannot be displaced and so the gas cannot expand. The gas influx will rise, due to buoyancy, but will maintain its high pressure since it cannot expand. As a result of this P_{ann} will increase and higher pressures will be exerted all down the wellbore (note the increase in bottom hole pressure). The situation is as shown in Figure 14.

This increase in annulus, and therefore bottom hole, pressure will be reflected in the drillpipe pressure ($P_{ph} = b_{hp} - \rho_m d$). This situation can, therefore, be identified by a simultaneous rise in drillpipe and annulus pressure.

It is evident that this situation cannot be allowed to develop as it may lead to the problems mentioned earlier (casing bursting or underground blow-out). From the point at which the well is shut in the drillpipe and annulus pressures should be continuously monitored. If P_{ann} and P_{dp} continue to rise simultaneously it must be assumed that a high pressure gas bubble is rising in the annulus. In this case, the pressure must be bled off from the annulus by opening the choke. Only small volumes (1/4 - 1/2 bbl) should be bled off at a time. By opening and closing the choke the gas is allowed to expand, and the pressure should gradually fall. The process should be continued until P_{dp} returns to its original shut in value (again P_{dp} is being used as a bottom hole pressure gauge). This procedure can be carried out until preparations to kill the well are complete. During this procedure no further influx of fluids will occur, provided P_{dp} remains above its original value.

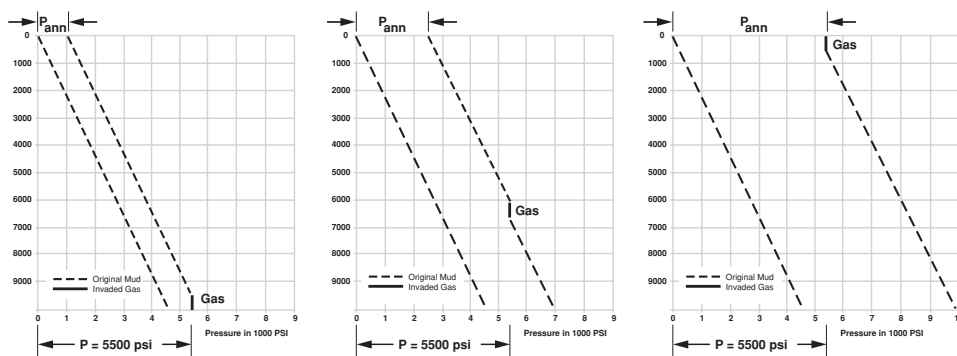

Figure 14 Migration of gas bubble which is not allowed to expand

4.8 MAASP

Another important parameter which must be calculated is the maximum allowable annular surface pressure (MAASP). The MAASP is the maximum pressure that can be allowed to develop at surface before the fracture pressure of the formation

just below the casing shoe is exceeded. Remember that an increase in the annulus pressure at surface will mean that the pressures along the entire wellbore are increasing also. Normally the weakest point in a drilled well is the highest point in the open hole section (i.e. at the previous casing shoe). During the well control operation it is important that the pressure is not allowed to exceed the fracture gradient at this weakest point. The fracture pressure of the formation just below the casing shoe will be available from leak off tests carried out after the casing was set. If no leak-off test was carried out an estimate can be made by taking a percentage of the minimum geostatic gradient for that depth.

If an influx occurs and the well is killed with a kill mud this calculation should be repeated to determine the new MAASP. The MAASP should not exceed 70% of the burst resistance of the casing.

5. WELL KILLING PROCEDURES

The procedure used to kill the well depends primarily on whether the kick occurs whilst drilling (there is a drillstring in the well) or whilst tripping (there is no drillstring in the well).

5.1 Drillstring out of the Well

One method of killing a well when there is no drillstring in the hole is the **Volumetric Method**. The volumetric method uses the expansion of the gas to maintain bottom hole pressure greater than formation pressure. Pressures are adjusted by bleeding off at the choke in small amounts. This is a slow process which maintains constant bottom hole pressure while allowing the gas bubble to migrate to surface under the effects of buoyancy. When the gas reaches surface it is gradually bled off whilst mud is pumped slowly into the well through the kill line. Once the gas is out of the well, heavier mud must be circulated. This can be done with a **snubbing unit**. This equipment allows a small diameter pipe to be into the hole through the closed BOPs.

5.2 Drillstring in the Well

When the kick occurs during drilling, the well can be killed directly since:

- The formation fluids can be circulated out
- The existing mud can be replaced with a mud with sufficient density to overbalance the formation pressure

If a kick is detected during a trip the drillstring must be *stripped* to bottom, otherwise the influx cannot be circulated out. Stripping is the process by which pipe is allowed to move through the closed BOPs under its own weight. Snubbing is where the pipe is forced through the BOP mechanically.

There are basically two methods of killing the well when the drillstring is at the bottom of the borehole. These are:

- The One Circulation Method
- The Drillers Method

5.2.1 The "One circulation Method" ("balanced mud density" or "wait and weight" method):

The procedure used in this method is to circulate out the influx and circulate in the heavier mud simultaneously. The influx is circulated out by pumping kill mud down the drillstring displacing the influx up the annulus. The kill mud is pumped into the drillstring at a constant pump rate and the pressure on the annulus is controlled on the choke so that the bottomhole pressure does not fall, allowing a further influx to occur.

The advantages of this method are:

- Since heavy mud will usually enter the annulus before the influx reaches surface the annulus pressure will be kept low. Thus there is less risk of fracturing the formation at the casing shoe.
- The maximum annulus pressure will only be exerted on the wellhead for a short time
- It is easier to maintain a constant P_{bh} by adjusting the choke.

b. Driller's Method (Two Circulation Method)

In this method the influx is first of all removed with the original mud. Then the well is displaced to heavier mud during a second circulation.

The one circulation method is generally considered better than the Drillers method since it is safer, simpler and quicker. Its main disadvantage is the time taken to mix the heavier mud, which may allow a gas bubble to migrate.

5.3 One Circulation Well Killing Method

When an influx has been detected the well must be shut in immediately. After the pressures have stabilised, the drillpipe pressure (P_{dp}) and the annulus pressure (P_{ann}) should be recorded. The required mud weight can then be calculated using Equation 7.

These calculations can be conducted while the heavy, kill mud is being mixed. These are best done in the form of a worksheet (Figure 12). It is good practice to have a standard worksheet available in the event of such an emergency. Certain information should already be recorded (capacity of pipe, existing mud weight, pump output).

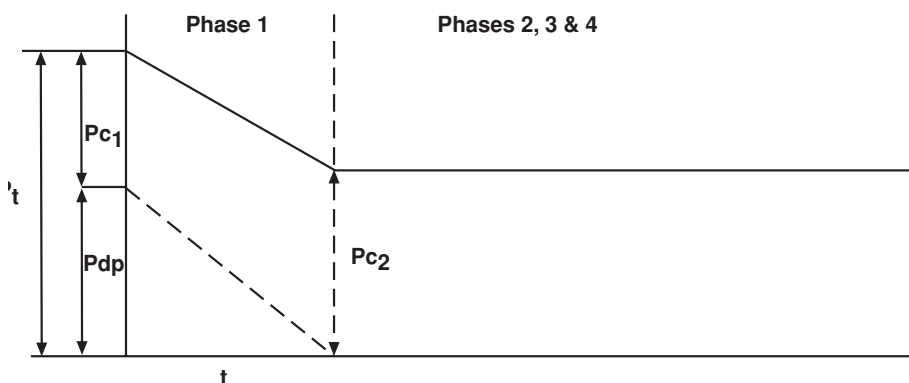

Figure 15 Standpipe pressure versus time

Notice on the worksheet that a slow pump rate is required. The higher the pump rate the higher the pressure drop, in the drillstring and annulus, due to friction. A low pump rate should, therefore, be used to minimise the risk of fracturing the formation. (A kill rate of 1-4 bbls/min. is recommended). The pressure drop (P_{c1}) which occurs while pumping at the kill rate will be known from pump rate tests which are conducted at regular intervals during the drilling operation. It is assumed that this pressure drop applies only to the drillstring and does not include the annulus. Initially, the pressure at the top of the drillstring, known as the **standpipe pressure** will be the sum of $P_{dp} + P_{c1}$ (Figure 15). The phrase **standpipe pressure** comes from the fact that the pressure gauge which is used to measure the pressure on the drillstring is connected to the standpipe. As the heavy mud is pumped down the drillstring, the standpipe pressure will change due to:

- Larger hydrostatic pressure from the heavy mud
- Changing circulating pressure drop due to the heavy mud

By the time the heavy mud reaches the bit the initial shut-in pressure P_{dp} should be reduced to zero psi. The standpipe pressure should then be equal to the pressure drop due to circulating the heavier mud

$$\text{i.e.} \quad P_{c2} = P_{c1} \times \frac{\rho_k}{\rho_m}$$

where,

ρ_k = kill mud gradient

ρ_m = original mud gradient

The time taken (or strokes pumped) for the drillstring volume to be displaced to heavy mud can be calculated by dividing the volumetric capacity of the drillstring by the pump output. This information is plotted on a graph of standpipe pressure vs. time or number of pump strokes (volume pumped). This determines the profile of how the standpipe pressure varies with time and number of pump strokes, during the kill procedure.

The one circulation method can be divided into 4 stages and these will be discussed separately. When circulating the influx out there will be a pressure drop across the choke, P_{choke} . The pressure drop through the choke plus the hydrostatic head in the annulus should be equal to the formation pressure, P_f . Thus P_{choke} is equivalent to P_{ann} when circulating through a choke.

Phase I (displacing drillstring to kill mud)

As the kill mud is pumped at a constant rate down the drillstring the choke is opened. The choke should be adjusted to keep the standpipe pressure decreasing according to the pressure vs. time plot discussed above. In fact the pressure is reduced in steps by maintaining the standpipe pressure constant for a period of time and opening the choke to allow the pressure to drop in regular increments. Once the heavy mud completely fills the drillstring the standpipe pressure should become equal to P_{c2} . The pressure on the annulus usually increases during phase I due to the reduction in hydrostatic pressure caused by gas expansion in the annulus.

Phase II (pumping heavy mud into the annulus until influx reaches the choke)

During this stage of the operation the choke is adjusted to keep the standpipe pressure constant (i.e. standpipe pressure = P_{c2}). The annulus pressure will vary more significantly than in phase I due to two effects:

- The increased hydrostatic pressure due to the heavy mud entering the annulus will tend to reduce P_{ann} .
- If the influx is gas, the expansion of the gas will tend to increase P_{ann} since some of the annular column of mud is being replaced by gas, leading to a decrease in hydrostatic pressure in the annulus.

The profile of annulus pressure during phase II therefore depends on the nature of the influx (Figure 16).

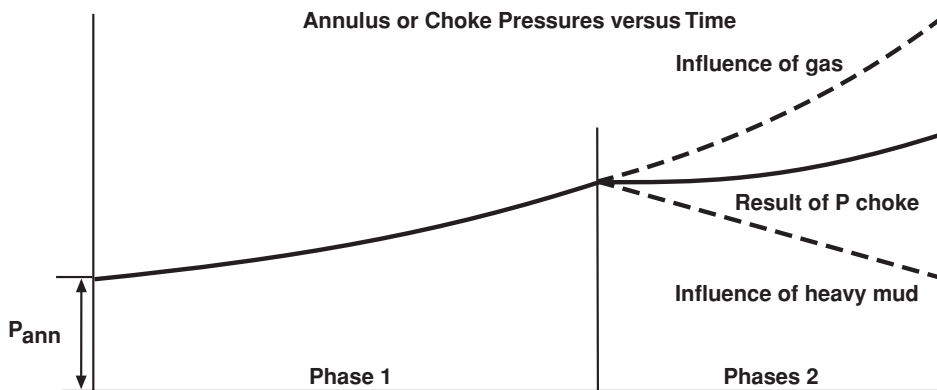

Figure 16 Effect of different kick fluids on annulus pressure

Phase III (all the influx removed from the annulus)

As the influx is allowed to escape, the hydrostatic pressure in the annulus will increase due to more heavy mud being pumped through the bit to replace the influx. Therefore, P_{ann} will reduce significantly. If the influx is gas this reduction may be very severe and cause vibrations which may damage the surface equipment (choke lines and choke manifold should be well secured). As in phase II the standpipe pressure should remain constant.

Phase IV (stage between all the influx being expelled and heavy mud reaching surface)

During this phase all the original mud is circulated out of the annulus and the annulus is completely full of heavy mud. If the mudweight has been calculated correctly, the annulus pressure will be equal to 0 (zero), and the choke should be fully open. The standpipe pressure should be equal to P_{c2} . To check that the well is finally dead the pumps can be stopped and the choke closed. The pressures on the drillpipe and the annulus should be 0 (zero). If the pressures are not zero continue circulating the heavy weight mud. When the well is dead, open the annular preventer, circulate, and condition the mud prior to resuming normal operations.

Summary of One Circulation Method

The underlying principle of the one circulation method is that bottom hole pressure, P_{bh} is maintained at a level greater than the formation pressure throughout the operation, so that no further influx occurs. This is achieved by adjusting the choke, to keep the standpipe pressure on a planned profile, whilst circulating the required mudweight into the well. A worksheet may be used to carry out the calculations in an orderly fashion and provide the required standpipe pressure profile. While the choke is being adjusted the operator must be able to see the standpipe pressure gauge and the annulus pressure gauge. Good communication between the choke operator and the pump operator is important.

Figure 17 shows the complete standpipe and annulus pressure profiles during the procedure. Notice that the maximum pressure occurs at the end of phase II, just before the influx is expelled through the choke, in the case of a gas kick .

Safety factors are sometimes built into the procedure by:

- Using extra back pressure (200 psi) on the choke to ensure no further influx occurs. The effect of this is to raise the pressure profiles in Figure 16 by 200 psi.
- Using a slightly higher mud weight. Due to the uncertainties in reading and calculating mud densities it is sometimes recommended to increase mud weight by 0.5 ppg more than the calculated kill weight. This will slightly increase the value of P_{c2} , and mean that the shut in drill pipe pressure at the end of phase I will be negative. Whenever mud weight is increased care should be taken not to exceed the fracture pressure of the formations in the openhole. (An increase of 0.5 ppg mud weight means an increased hydrostatic pressure of 260 psi at 10000ft). Some so-called safety margins may lead to problems of **overkill**.

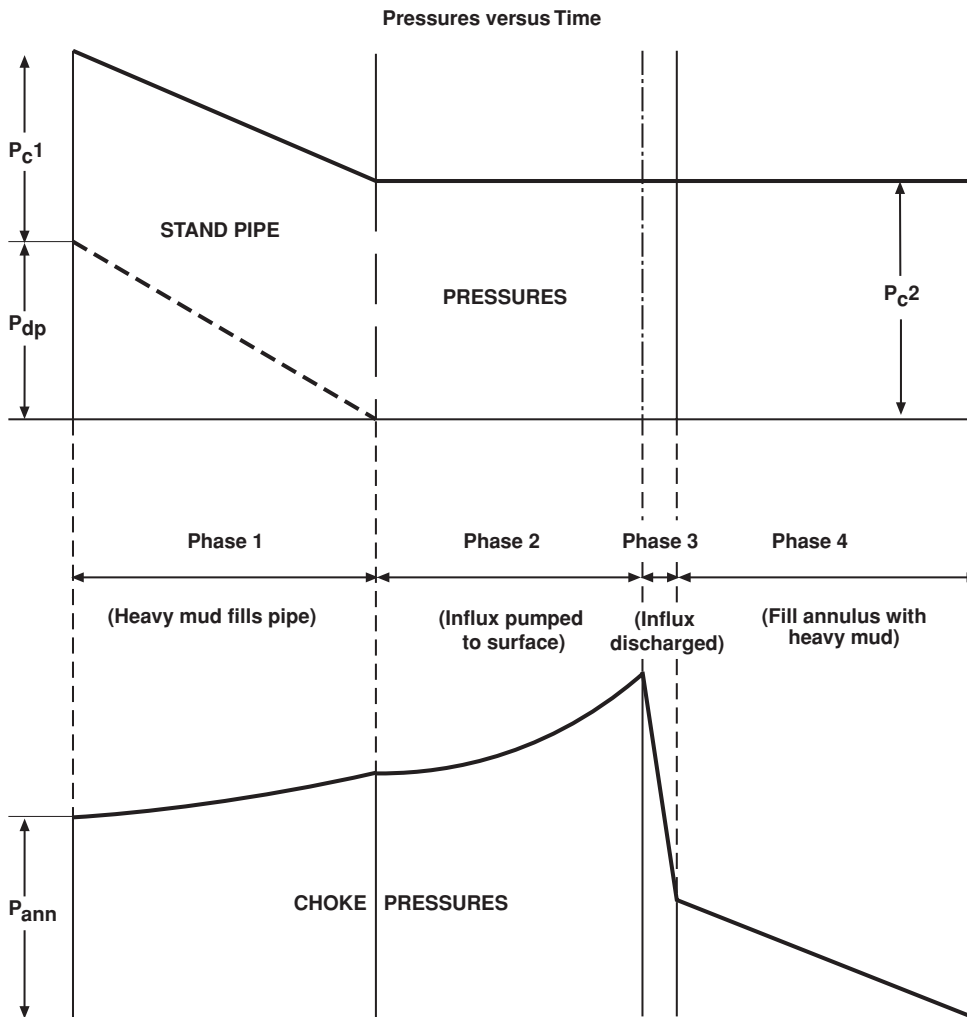

Figure 17 Summary of standpipe and annulus pressure during the "one circulation" method

5.4 Drillers Method for Killing a Well

The Drillers Method for killing a well is an alternative to the One Circulation Method. In this method the influx is first circulated out of the well with the original mud. The heavyweight kill mud is then circulated into the well in a second stage of the operation. As with the one circulation method, the well will be closed in and the circulation pressures in the system are controlled by manipulation of the choke on the annulus. This procedure can also be divided conveniently into 4 stages:

Phase I (circulation of influx to surface)

During this stage the well is circulated at a constant rate, with the original mud. Since the original mudweight is being circulated the standpipe pressure will equal $P_{dp} + P_{c1}$ throughout this phase of the operation. If the influx is gas then P_{ann} will increase significantly (Figure 18). If the influx is not gas the annulus pressure will remain fairly static.

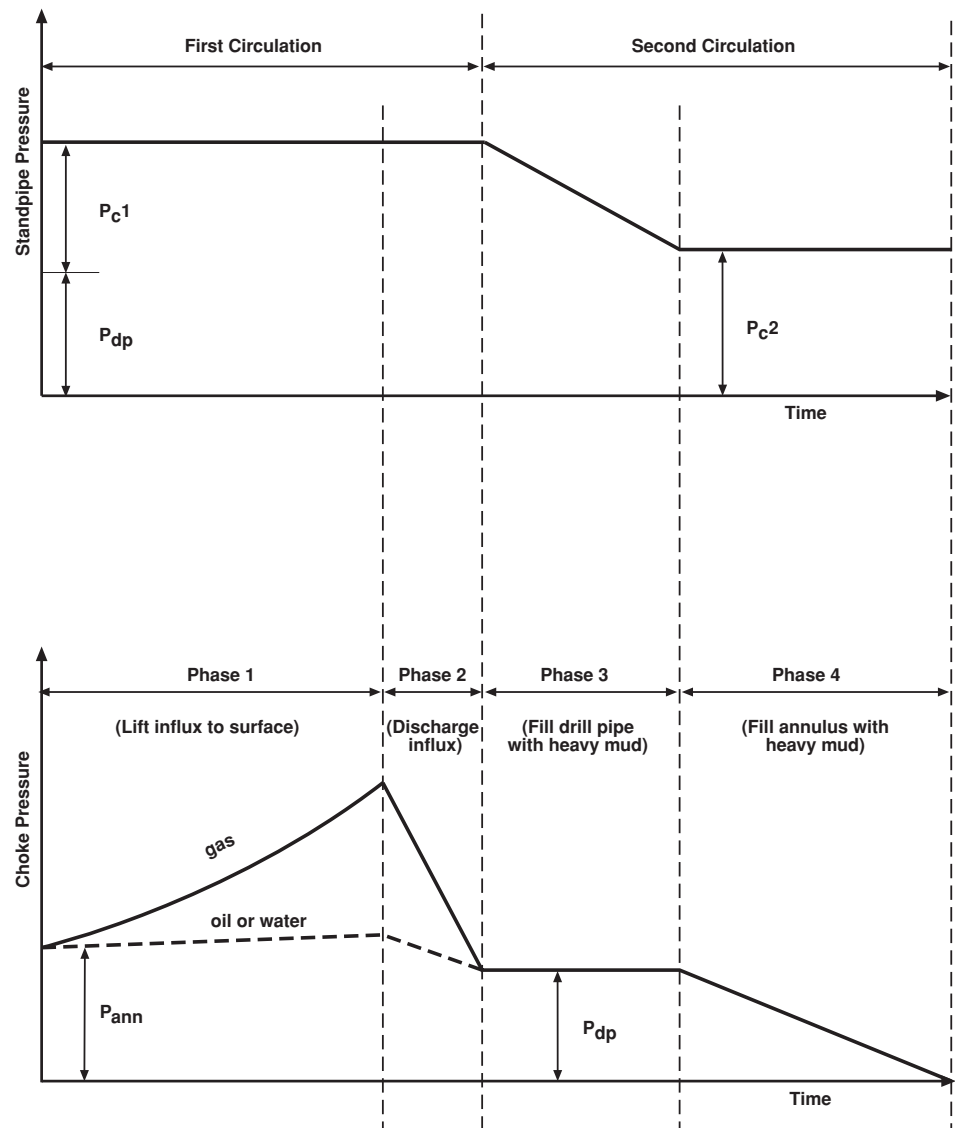

Figure 18 Summary of standpipe and annulus pressure during the "Drillers" method

Phase II (discharging the influx)

As the influx is discharged the choke will be progressively opened. When all the influx has been circulated out P_{ann} should reduce until it is equal to the original shut in drillpipe pressure P_{dp} so that $P_{ann} + \rho_m d = P_f$

Phase III (filling the drillstring with heavy mud)

At the beginning of the second circulation, the stand pipe pressure will still be $P_{dp} + P_{c1}$, but will be steadily reduced by adjusting the choke so that by the end of phase III the standpipe pressure = P_{c2} (as before).



Phase IV (filling the annulus with heavy mud)

In this phase P_{ann} will still be equal to the original P_{dp} , but as the heavy mud enters the annulus P_{ann} will reduce. By the time the heavy mud reaches surface $P_{ann} = 0$ and the choke will be fully opened. The pressure profiles for the drillers method are shown in Figure 17.

Exercise 4 Well Killing Technique

- Briefly explain the essential differences between the "one circulation method" and the "drillers method" for killing a well.
 - Briefly explain how and why the wellbore pressure is monitored and controlled throughout the well killing operation (assuming that the "one circulation method" is being used to kill the well).
-

6. BLOWOUT PREVENTION (BOP) EQUIPMENT

The blowout prevention (BOP) equipment is the equipment which is used to shut-in a well and circulate out an influx if it occurs. The main components of this equipment are the **blowout preventers or BOP's**. These are valves which can be used to close off the well at surface. In addition to the BOP's the BOP equipment refers to the auxiliary equipment required to control the flow of the formation fluids and circulate the kick out safely.

There are 2 basic types of blowout preventer used for closing in a well:

- Annular (bag type) or
- Ram type.

It is very rare for only one blowout preventer to be used on a well. Two, three or more preventers are generally stacked up, one on top of the other to make up a **BOP stack**. This provides greater safety and flexibility in the well control operation. For example: the additional BOPs provide redundancy should one piece of equipment fail; and the different types of ram (see below) provide the capability to close the well whether there is drillpipe in the well or not. When drilling from a floating vessel the BOP stack design is further complicated and will be dealt with later.

6.1 Annular Preventers

The main component of the annular BOP (Figure 18) is a high tensile strength, circular rubber packing unit. The rubber is moulded around a series of metal ribs. The packing unit can be compressed inwards against drillpipe by a piston, operated by hydraulic power.

The advantage of such a well control device is that the packing element will close off around any size or shape of pipe. An annular preventer will also allow pipe to be stripped in (run into the well whilst containing annulus pressure) and out and rotated, although its service life is much reduced by these operations. The rubber packing element should be frequently inspected for wear and is easily replaced.

The annular preventer provides an effective pressure seal (2000 or 5000 psi) and is usually the first BOP to be used when closing in a well (Figure 19). The closing mechanism is described in Figure 20.

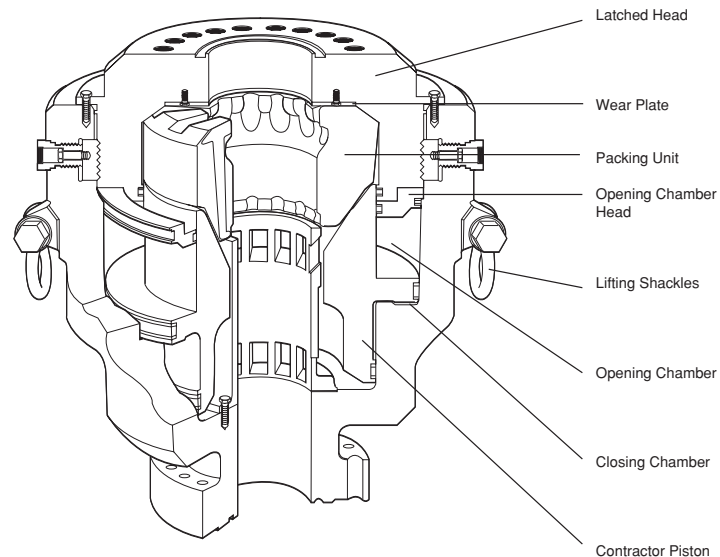
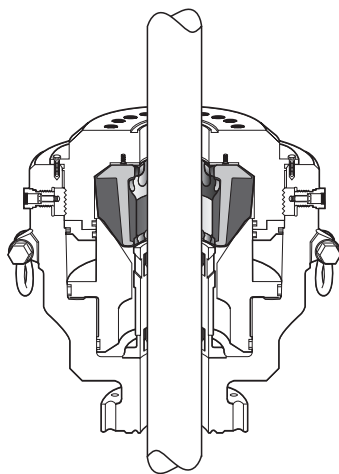

Figure 19 Annular type BOP (Courtesy of Hydril*)

6.2 Ram Type Preventers

Ram type preventers (Figure 22) derive their name from the twin ram elements which make up their closing mechanism. Three types of ram preventers are available:

- Blind rams - which completely close off the wellbore when there is no pipe in the hole.
- Pipe rams - which seal off around a specific size of pipe thus sealing of the annulus. In 1980 variable rams were made available by manufacturers. These rams will close and seal on a range of drillpipe sizes.
- Shear rams which are the same as blind rams except that they can cut through drillpipe for emergency shut-in but should only be used as a last resort. A set of pipe rams may be installed below the shear rams to support the severed drillstring.



Annular preventers seal off the annulus between the drillstring and BOP stack. During normal well-bore operations, the BOP is kept fully open by holding the contractor piston down. This position permits passage of tools, casing and other items up to the full bore size of the BOP as well as providing maximum annulus flow of drilling fluids. The BOP is maintained in the open position by application of hydraulic pressure to the opening chamber, this ensures positive control of the piston during drilling and reduces wear caused by vibration.

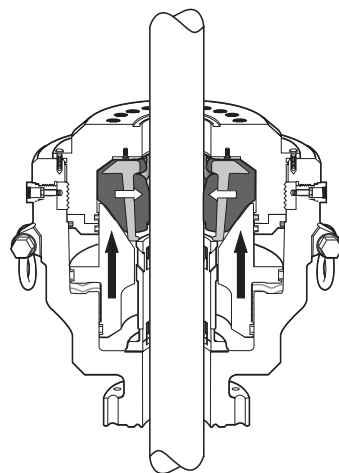

The contractor piston is raised by applying hydraulic pressure to the closing chamber. This raises the piston, which in turn squeezes the steel reinforced packing unit inward to seal the annulus around the drill string. The closing pressure should be regulated with a separate pressure regulator valve for the annular BOP.

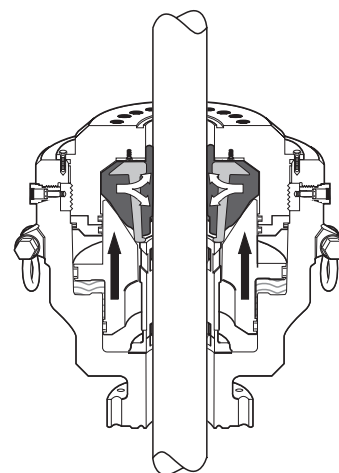

The packing unit is kept in compression throughout the sealing area thus assuring a tough, durable seal off against virtually any drill string shape, kelly, tool joint, pipe or tubing to full rated working pressure. Application of opening chamber pressure returns the piston to the full down position allowing the packing unit to return to full open bore through the natural resiliency of the rubber.

Figure 20 Details of closing mechanism on an annular preventer (Courtesy of Hydril*)

The sealing elements are again constructed in a high tensile strength rubber and are designed to withstand very high pressures. The elements shown in Figure 21 are easily replaced and the overall construction is shown in Figure 22. Pipe ram elements must be changed to fit around the particular size of pipe in the hole. To reduce the size of a BOP stack two rams can be fitted inside a single body. The weight of the drillstring can be suspended from the closed pipe rams if necessary.

6.3 Drilling Spools

A drilling spool is a connector which allows choke and kill lines to be attached to the BOP stack. The spool must have a bore at least equal to the maximum bore of the uppermost casing spool. The spool must also be capable of withstanding the same pressures as the rest of the BOP stack (Figure 23). These days outlets for connection of choke and kill lines have been added to the BOP ram body (Figure 22) and drilling spools are less frequently used. These outlets save space and reduce the number of connections and therefore potential leak paths.

6.4 Casing Spools

The wellhead, from which the casing strings are suspended are made up of casing spools. A casing spool will be installed after each casing string has been set. The BOP stack is placed on top of the casing spool and connected to it by flanged, welded or threaded connections. Once again the casing spool must be rated to the same pressure as the rest of the BOP stack. The casing spool outlets should only be used for the connection of the choke and/or kill lines in an emergency.

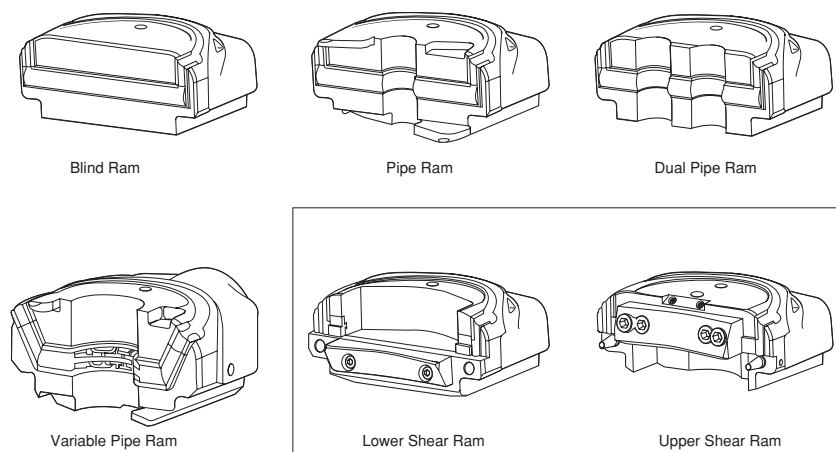

Figure 21 Types of ram elements (Courtesy of Hydril*)

6.5 Diverter System

The diverter is a large, low pressure, annular preventer equipped with large bore discharge flowlines. This type of BOP is generally used when drilling at shallow depths below the conductor. If the well were to kick at this shallow depth, closing in and attempting to contain the downhole pressure would probably result in the formations below the conductor fracturing and cratering of the site or at least hydrocarbons coming to surface outside of the conductor string. The purpose of a diverter is to allow the well to flow to surface safely, where it can be expelled safely through a pipeline leading away from the rig. The kick must be diverted

safely away from the rig through the large bore flowlines. The pressure from such a kick is likely to be low (500 psi), but high volumes of fluid can be expected. The diverter should have a large outlet with one full opening valve. The discharge line should be as straight as possible and firmly secured. Examples of diverter systems are given in API RP 53.

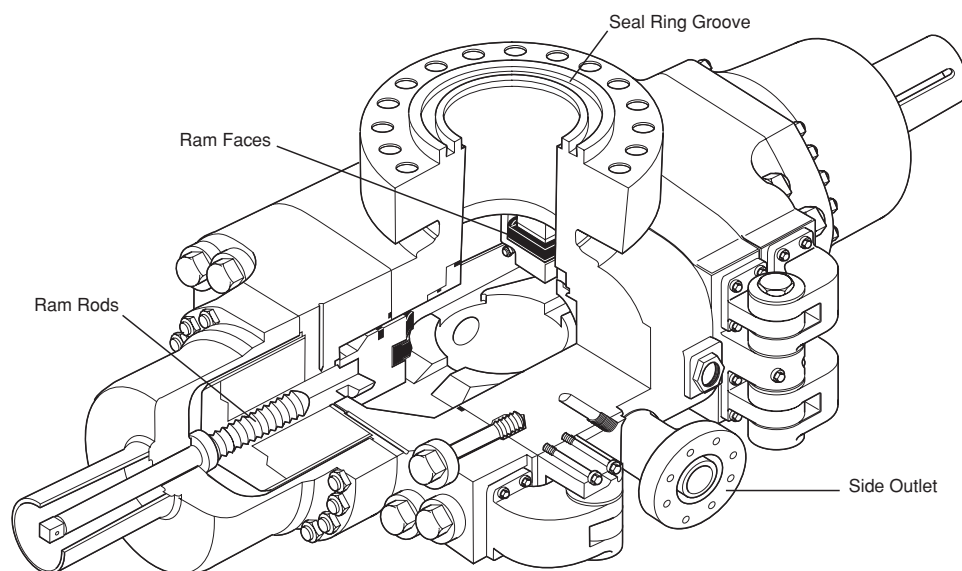

Figure 22 Details of ram preventer (Courtesy of Hydril*)

6.6 Choke and Kill Lines

When circulating out a kick the heavy fluid is pumped down the drillstring, up the annulus and out to surface. Since the well is closed in at the annular preventer the wellbore fluids leave the annulus through the side outlet below the BOP rams or the drilling spool outlets and pass into a high pressure line known as the **choke line**. The choke line carries the mud and influx from the BOP stack to the choke manifold. The **kill line** is a high pressure pipeline between the side outlet, opposite the choke line outlet, on the BOP stack and the mud pumps and provides a means of pumping fluids downhole when the normal method of circulating down the drillstring is not possible.

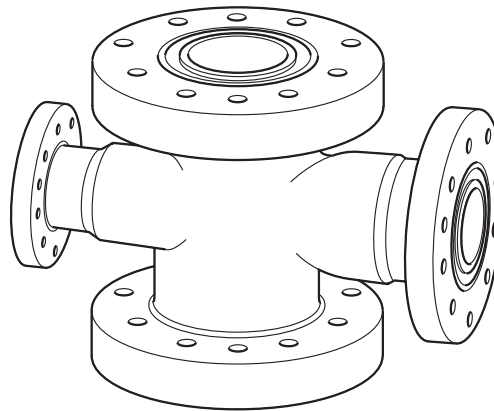

Figure 23 Flanged drilling spool

6.7 Choke Manifold

The choke manifold is an arrangement of valves, pipelines and chokes designed to control the flow from the annulus of the well during a well killing operation. It must be capable of:

- Controlling pressures by using manually operated chokes or chokes operated from a remote location.
- Diverting flow to a burning pit, flare or mud pits.
- Having enough back up lines should any part of the manifold fail.
- A working pressure equal to the BOP stack.

Since, during a gas kick, excessive vibration may occur it must be well secured.

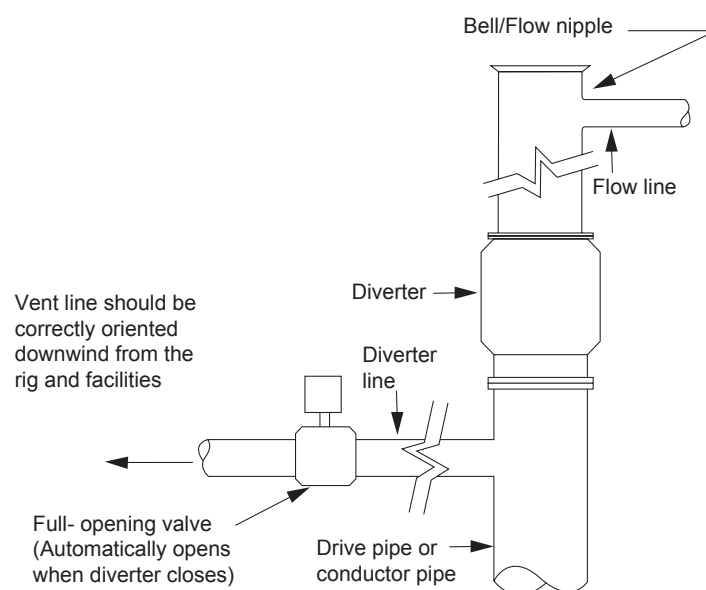

Figure 24 Diverter System

6.8 Choke Device

A choke is simply a device which applies some resistance to flow. The resistance creates a back pressure which is used to control bottomhole pressure during a well killing operation. Both fixed chokes and adjustable chokes are available (Figure 25). The choke can be operated hydraulically or manually if necessary.

6.9 Hydraulic Power Package (Accumulators)

The opening and closing of the BOP's is controlled from the rig floor. The control panel is connected to an **accumulator system** which supplies the energy required to operate all the elements of the BOP stack. The accumulator consists of cylinders which store hydraulic oil at high pressure under a compressed inert gas (nitrogen). When the BOPs have to be closed the hydraulic oil is released (the system is designed to operate in less than 5 seconds). Hydraulic pumps replenish the accumulator with the same amount of fluid used to operate the preventers (Figure 26).

The accumulator must be equipped with pressure regulators since different BOP elements require different closing pressures (e.g. annulus preventers require 1500 psi while some pipe rams may require 3000 psi). Another function of the accumulator system is to maintain constant pressure while the pipe is being stripped through the BOPs.

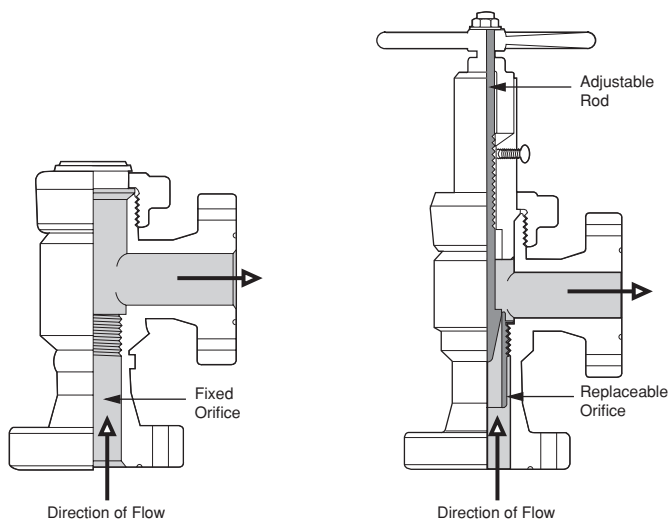

Figure 25 Choke devices (a) positive (fixed orifice) choke (b) adjustable choke (rubber or steel elements)

6.10 Internal Blow-out Preventers

There are a variety of tools used to prevent formation fluids rising up inside the drillpipe. Among these are float valves, safety valves, check valves and the kelly cock. A float valve installed in the drillstring will prevent upward flow, but allow normal circulation to continue. It is more often used to reduce backflow during connections. One disadvantage of using a float valve is that drill pipe pressure cannot be read at surface. A manual safety valve should be kept on the rig floor at all times. It should be a full opening ball-type valve so there is no restriction to flow. This valve is installed onto the top of the drillstring if a kick occurs during a trip.

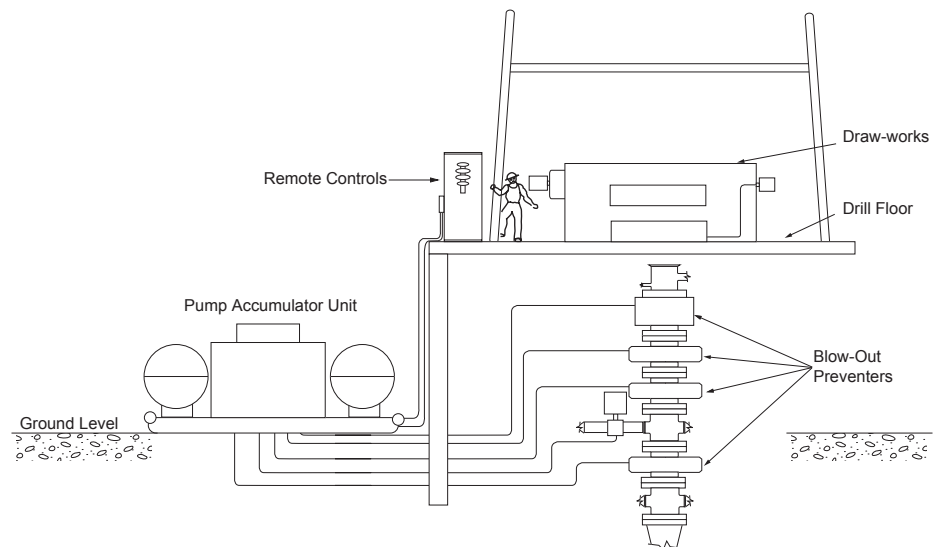

Figure 26 BOP accumulator system

7. BOP STACK ARRANGEMENTS

The individual annular and ram type blowout preventers are stacked up, one on top of the other, to form a BOP stack. The configuration of these components and the associated choke and kill lines depends on the operational conditions and the operational flexibility that is required.

7.1 General Considerations

The placement of the elements of a BOP stack (both rams and circulation lines) involves a degree of judgement, and eventually compromise. However, the placement of the rams and the choke and kill line configuration should be carefully considered if optimum flexibility is to be maintained. Although there is no single optimum stack configuration, consider the configuration of the rams and choke and kill lines in the BOP stack shown in Figure 27:

- There is a choke and kill line below each pipe ram to allow well killing with either ram.
- Either set of pipe rams can be used to kill the well in a normal kill operation (Figure 28).
- If there is a failure in the surface pumping equipment at the drillfloor the string can be hung off the lower pipe rams, the blind rams closed and a kill operation can be conducted through the kill line (Figure 29).
- If the hydril fails the pipe can be stripped into the well using the pipe rams. In this operation the pipe is run in hole through the pipe rams. With the pressure on the pipe rams being sufficient to contain the pressure in the well. When a tooljoint reaches the upper pipe ram the upper ram is opened and the tooljoint allowed to pass. The upper pipe ram is then closed and the lower opened to allow the tooljoint to pass (Figure 30). This operation is known as **ram to ram stripping**.

This arrangement is shown as an illustration of considerations and compromise and should not be considered as a ‘standard’.

The placement of the choke and kill lines is also a very important consideration when designing the stackup. Ideally these lines are never made up below the bottom ram. However, compromise may be necessary.

The following general observations can be made about the arrangement detailed in Figure 27:

1. No drilling spools are used. This minimises the number of connections and chances of flange leaks.
2. The double ram is placed on top of a single ram unit. This will probably provide sufficient room so that the pipe may be sheared and the tool joint still be held in the lower pipe ram.

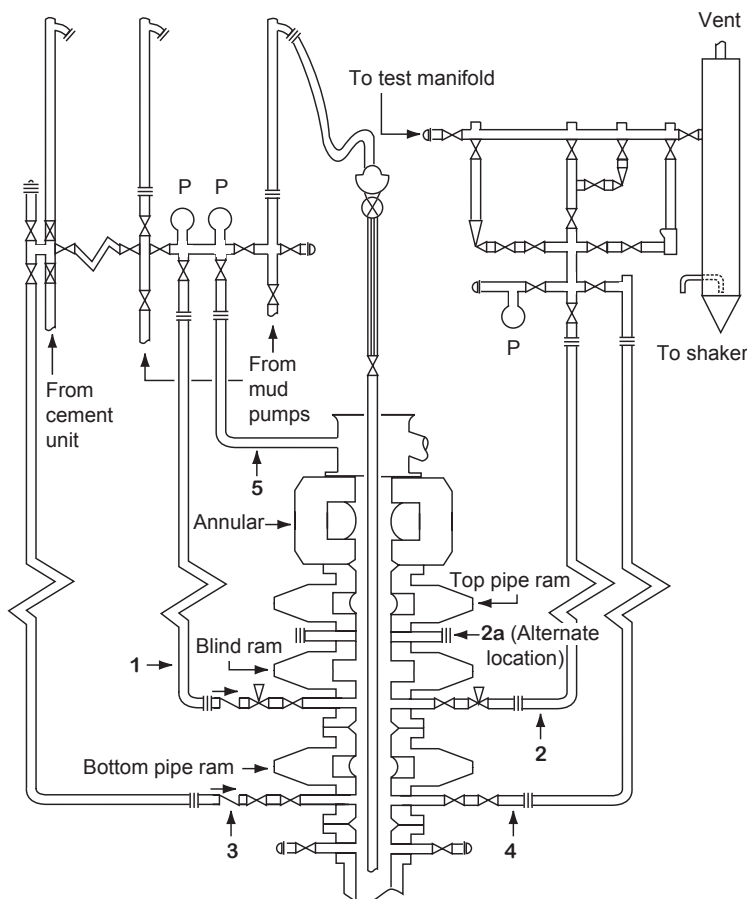

Figure 27 BOP Stack and choke and kill line arrangement

3. Check valves are located in each of the kill wing valve assemblies. This will stop flow if the kill line ruptures under high pressure killing operations.

4. Inboard valves adjacent to the BOP stack on all flowlines are manually operated 'master' valves to be used only for emergency. Outboard valves should be used for normal killing operations. Hydraulic operators are generally installed on the primary (lines 1 and 2) choke and kill flowline outboard valves. This allows remote control during killing operations.
5. No choke or kill flowlines are connected to the casing-head outlets, but valves and unions are installed for emergency use only. It is not good practise to flow into or out of a casing head outlet. If this connection is ruptured or cutout, there is no control. Primary and secondary flowlines should all be connected to heavy duty BOP outlets or spools.

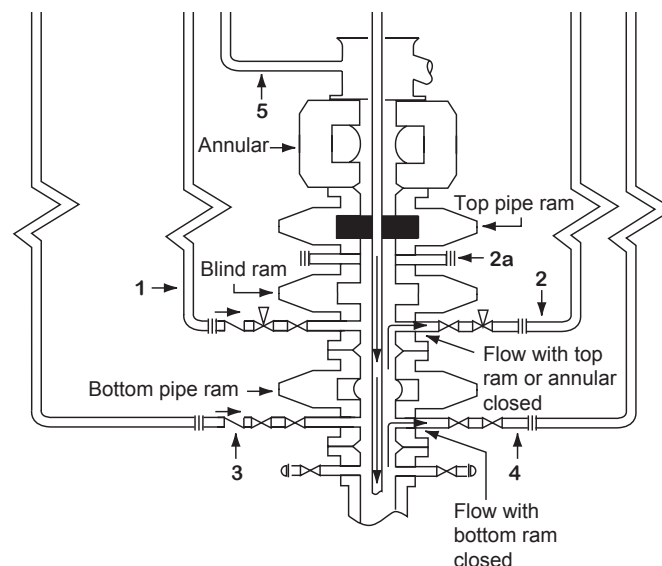

Figure 28 Normal kill operation

7.2 API Recommended Configurations

The stack composition depends on the pressures which the BOPs will be expected to cope with (i.e. the working pressures). The API publishes a set of recommended stack configurations but leaves the selection of the most appropriate configuration to the operator.

An example of the API code (API RP 53) for describing the stack arrangement is (Figure 31):

5M - 13 5/8" - RSRdAG

where,

5M refers to the working pressure = 5000 psi

13 5/8" is the diameter of the vertical bore

RSRdAG is the order of components from the bottom up

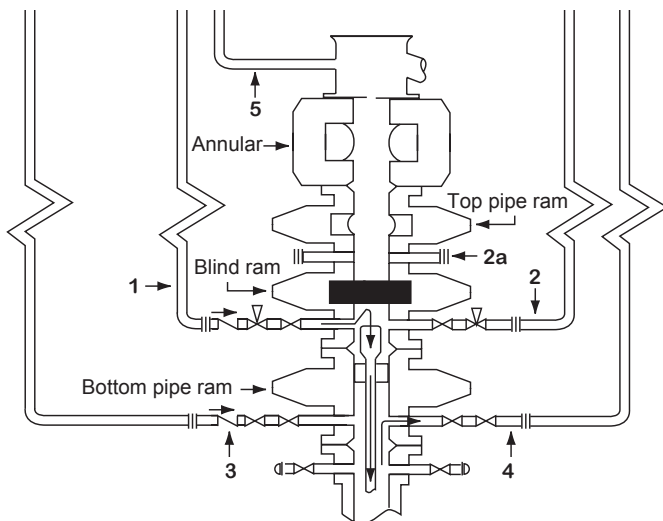

Figure 29 Killing through kill line

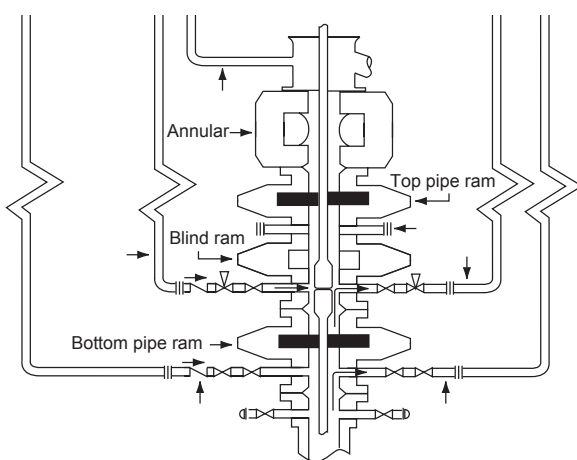

Figure 30 Ram to ram stripping operation

and where,

- G = rotating BOP for gas/air drilling
- A = annular preventer
- Rd = double ram-type preventer
- S = drilling spool
- R = single ram-type preventer

BOP stacks are generally classified in terms of their pressure rating. The following BOP stack arrangements are examples of those commonly used and given in API RP 53:

7.2.1 Low Pressure (2000 psi WP)

This stack (Figure 31) generally consists of one annular preventer a double ram-type preventer (one set of pipe rams plus one set of blind rams) or some combination of both. Such an assembly would only be used for surface hole and is not recommended for testing, completion or workover operations.

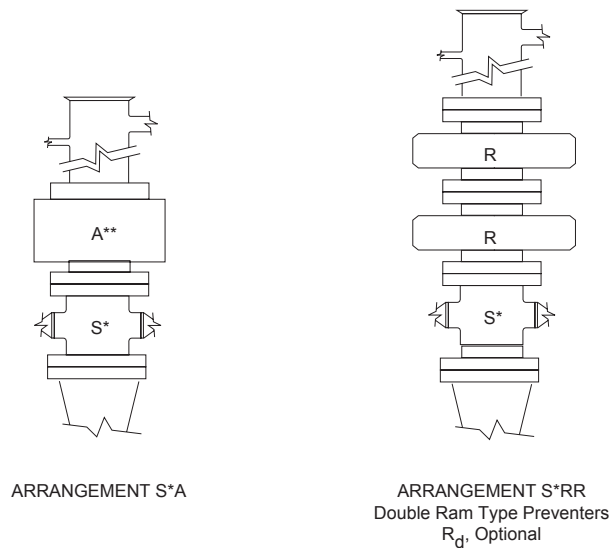

Figure 31 Low pressure stack

7.2.2 Normal Pressure (3000 or 5000 psi WP)

This stack (Figure 32) generally consists of one annular preventer and two sets of rams (pipe rams plus blind rams). As shown a double ram preventer could replace the two single rams.

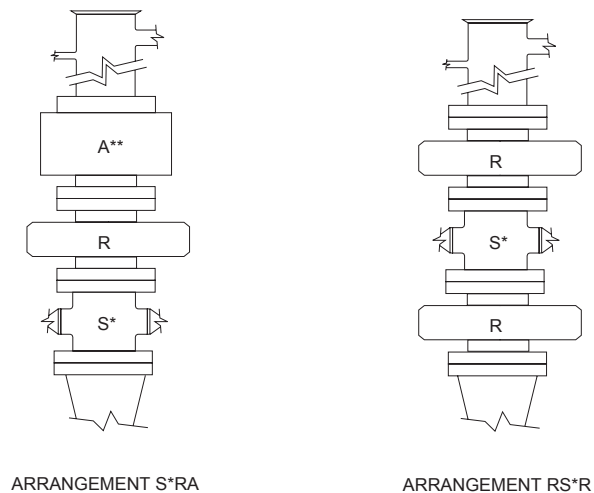

Figure 32(a) Normal pressure stack

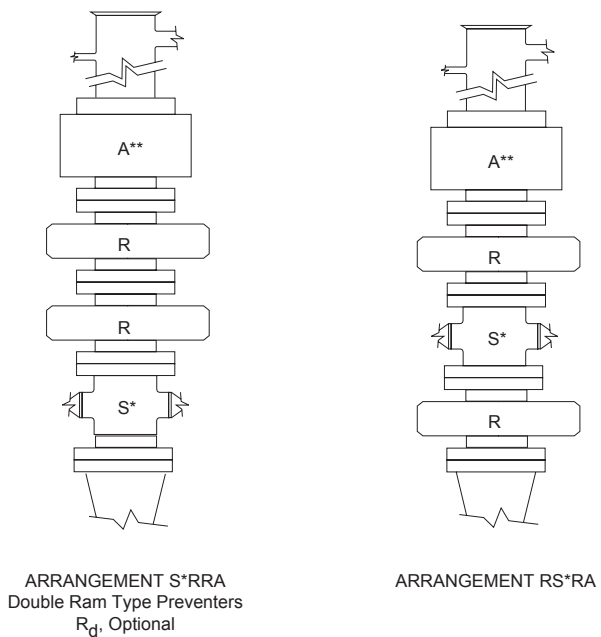

Figure 32 (b) Normal pressure stack

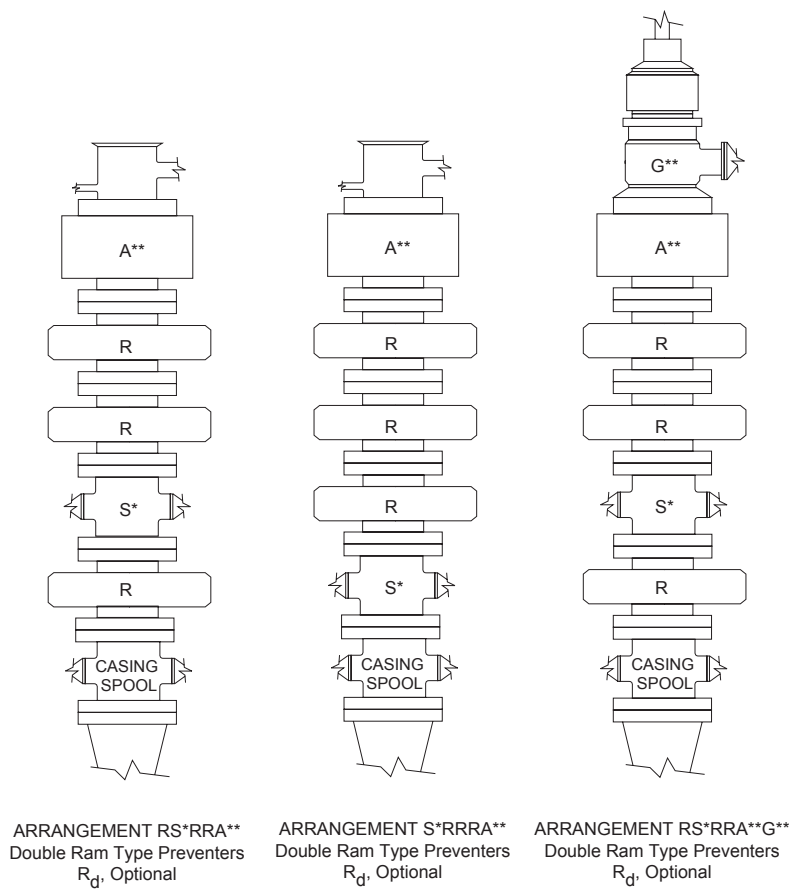

Figure 33 Abnormally high pressure stack

7.2.3 Abnormally High Pressure (10000 or 15000 psi WP)

This stack (Figure 33) generally consists of three ram type preventers (2 sets of pipe rams plus blind/shear rams). An annular preventer should also be included.

In all these arrangements the associated flanges and valves must have a pressure rating equal to that of the BOPs themselves. The control lines should be of seamless steel with chocksan joints or high pressure hoses may be used. These hoses must be rated at 3000 psi (i.e. accumulator pressure).

*Hydril is a registered trademark of Hydril Company of Houston, Texas which is protected by the laws of the United States of America, U.K. and other countries. The equipment depicted nearby is a patented invention of Hydril company which is protected by the laws of the United States of America, U.K. and other countries. Hydril company reserves all trademark and intellectual property rights, and no permission or license has been granted for the use thereof to any person.



ATTACHMENT 1

CASING/HOLE DATA

9 5/8" 53.5 lb/ft casing shoe 7000 ft.
8 1/2" hole 9100 ft

DRILLSTRING DATA :

5" 19.5 lb/ft drillpipe in hole (capacity = .0178 bbl/ft)
BHA - 360 ft of 6.25" x 2 13/16" collars (capacity = .0077 bbl/ft)

PUMP DATA :

Type - Triplex pump Output = 0.1428 bbls/stk
kill rate/circ. press. 14 spm @ 600 psi circ. pressure

MUD DATA :

Mud in hole 9.5ppg

DEPTH OF KICK :

9100 ft.

ANNULAR CAPACITIES :

Collar/Hole (6.25" Collar x 8 1/2" Hole) 0.0323 bbl/ft
D.P./Hole (5" Drillpipe x 8 1/2" Hole) 0.0459 bbl/ft
D.P./Casing (5" Drillpipe x 9 5/8" Casing) 0.0465 bbl/ft

Solutions to Exercises

Exercise 1 Impact of Mudweight and Hole Fillup on Bottomhole Pressure:

a. The overbalance at 8000ft would be :

$$((12 \times 0.052) \times 8000) - 4700 = 292 \text{ psi}$$

b. At 10 ppg the overbalance would be :

$$((10 \times 0.052) \times 8000) - 4700 = -540 \text{ psi}$$

In other words the well would be underbalanced by 540 psi with the consequent risk of an influx.

c. If the fluid level in the annulus dropped by 200 ft the effect would be to reduce the bottomhole pressure by :

$$200 \times (12 \times .052) = 124.8 \text{ psi}$$

Thus there would still be a net overbalance of 167.2 psi but the effect on bottomhole conditions is clear.

Exercise 2 Response to a Kick

See Text

Exercise 3 Killing Operation Calculations

a. The information required to kill the well is the:

Formation Pressure, and
Kill mudweight

$$\begin{aligned} \text{(i) Formation Pressure} &= P_{dp} + \rho_m d \\ &= 100 + (9.5 \times 0.052) \times 9100 \\ &= 4595.4 \text{ psi} \end{aligned}$$

$$\text{(ii) Kill Mudweight} = \frac{\text{Formation Pressure} + \text{Overbalance}}{d}$$

Assuming an overbalance of 200 psi

$$\begin{aligned} &= \frac{4595.4 + 200}{9100} \\ &= 0.527 \text{ psi/ft} \quad (10.13 \text{ ppg}) \end{aligned}$$

b. Nature of the Influx:

$$\text{Formation Pressure} = P_{ann} + \rho_m(d-h) + \rho_i(h)$$

$$h = \frac{\text{Volume of Influx}}{\text{Area Collars/Hole}}$$

$$h = \frac{10 \text{ bbls}}{0.0323 \text{ bbls/ft}}$$

$$= 309.6 \text{ ft}$$

$$4595.4 = 110 + (9.5 \times 0.052) \times (9100 - 309.6) + \rho_i(309.6)$$

$$142.9 = 309.6\rho_i$$

$$\rho_i = 0.462 \text{ psi/ft} \quad (\text{probably water influx})$$



c. The Time taken to circulate out the influx:

(i) The Total time taken to circulate out the influx will be:

$$\frac{\text{Total Capacity of Drillstring and Annulus (bbls)}}{\text{Pump Rate (bbls/min.)}}$$

- Total Capacity of Inside of Drillstring

$$= \frac{(9100 - 360) \times 0.0178}{+ 360 \times 0.0077} \quad \begin{array}{l} \text{(I.D. of Drillpipe)} \\ \text{(I.D. of Collars)} \end{array}$$

$$= 158 \text{ bbls}$$

- Total Capacity of Annulus

$$= 360 \times 0.0323 \quad \text{(Drillcollar/Hole Annulus)}$$

$$+ (9100 - 7000 - 360) \times 0.0459 \quad \text{(Drillpipe/Hole Annulus)}$$

$$+ 7000 \times 0.0465 \quad \text{(Drillpipe/Casing Annulus)}$$

$$= 417 \text{ bbls}$$

- Total Volume = 575 bbls

- Pump Rate = No. strokes per min. of pump x No. of bbls per stroke

$$= 14 \text{ strokes/min.} \times 0.1428 \text{ bbls/stroke}$$

$$= 1.992 \text{ bbls/min.}$$

Total Time to circulate out influx

$$= \frac{575}{1.992}$$

$$= 289 \text{ mins} \quad (4.8 \text{ hrs})$$

The time taken to complete each stage in the killing operation can also be calculated:

(ii) Time to End of stage 1 = $\frac{\text{Total Volume Pumped when Kill mud at bit}}{\text{Pump Rate}}$

$$= \frac{158 \text{ bbls}}{1.992}$$

$$= 79 \text{ mins}$$

d. Pump Pressure During stages 2, 3, and 4 of the killing operation

$$P_{c2} = \frac{\rho_k \times P_{c1}}{\rho_m}$$

$$= \frac{10.13 \times 600}{9.5}$$

$$= 639.8 \text{ psi}$$

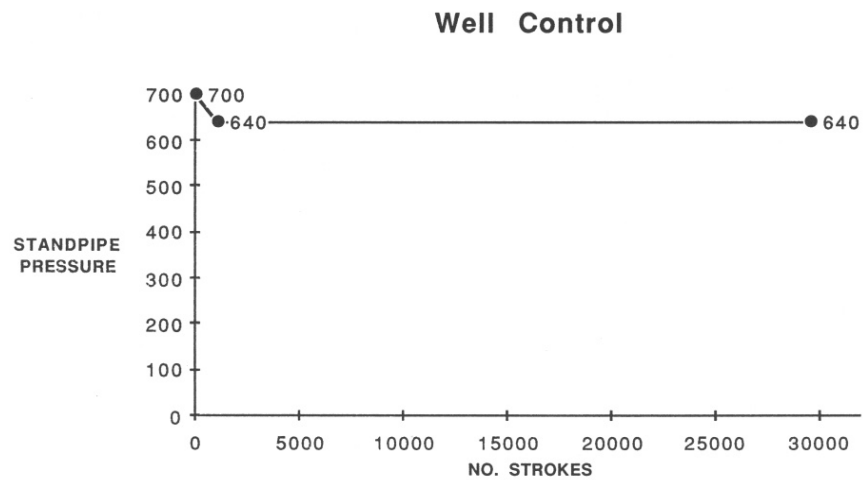

Casing 7

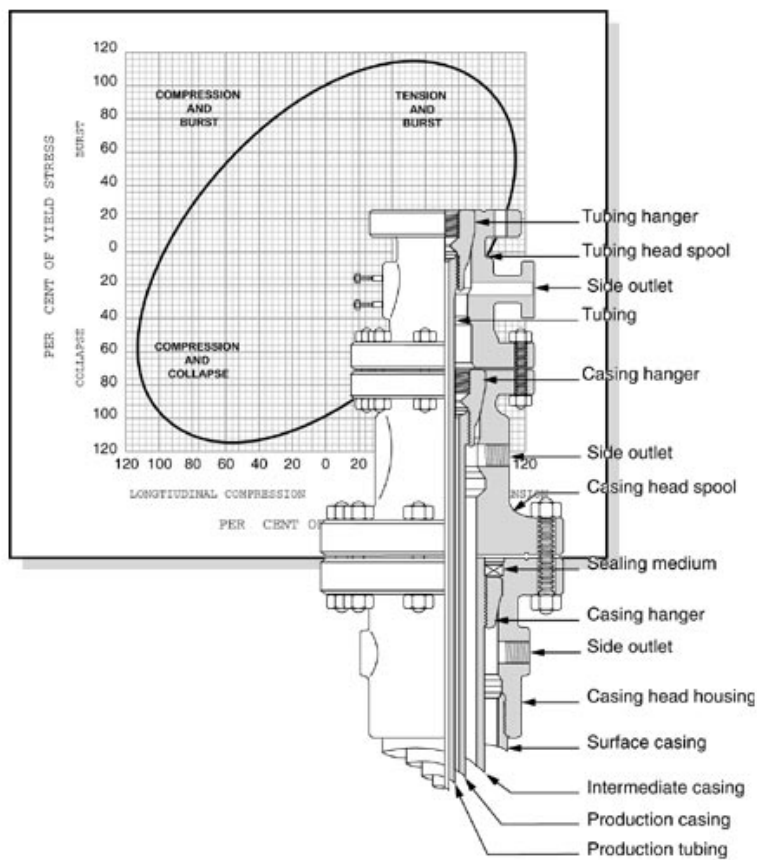

CONTENTS

1. INTRODUCTION
2. COMPONENT PARTS OF A CASING STRING
3. CASING TERMINOLOGY
 - 3.1 Conductor Casing (30" O.D.)
 - 3.2 Surface Casing (20" O.D.)
 - 3.3 Intermediate Casing (13 3/8" O.D.)
 - 3.4 Production Casing (9 5/8" O.D.)
 - 3.5 Liner (7" O.D.)
4. PROPERTIES OF CASING
 - 4.1 Casing Size (Outside Diameter - O.D.)
 - 4.2 Length of Joint
 - 4.3 Casing Weight
 - 4.4 Casing Grade
 - 4.5 Connections
5. API SPECIFICATIONS, STANDARDS AND BULLETINS
6. WELLHEADS AND CASING HANGERS
 - 6.1 Spool Type Wellhead
 - 6.2 Compact Spool (Speedhead)
 - 6.3 Casing Hangers
7. RIG-SITE OPERATIONS
 - 7.1 Handling Procedures
 - 7.2 Casing Running Procedures
 - 7.3 Casing Landing Procedures
 - 7.4 Liner Running Procedures
8. CASING DESIGN
 - 8.1 Introduction to the Casing Design Process
 - 8.1.1 Design Casing Scheme Configuration - Selecting Casing sizes and Setting Depths
 - 8.1.2 Define the Operational Scenarios and Consequent Loads on the Casing
 - 8.1.3 Calculate the Loads on the Casing and Select the Appropriate Weight and Grade of Casing
 - 8.2 Casing Design Rules Base
 - 8.3 Other design considerations
 - 8.4 Summary of Design Process





LEARNING OBJECTIVES

Having worked through this chapter the student will be able to:

General

- State the functions of Casing
- Define the terms: conductor; surface; intermediate; and production casing
- Describe the advantages of using a liner rather than a full string of casing.
- List and describe the loads which must be considered in the design of the casing.

Properties of Casing

- Describe the specific meaning of the terms used to describe the properties of casing: casing size, weight and grade
- Describe the various types of connection used on casing.

Wellheads and casing hangers

- Describe a conventional wellhead assembly
- Describe the sequence of operations associated with the installation of a spool type wellhead assembly
- Describe a compact spool wellhead and its advantages over the conventional wellhead
- Describe a conventional christmas tree and its function
- Describe the different types of casing hanger that are available and when each would be used.

Casing Running Operations

- Write a step by step program for a casing and liner running and landing operation
- Explain the reasons behind each step in the casing running operation.

Casing Design

- Describe the steps involved in the casing design process.
- Describe the main considerations in selecting the casing size and setting depths.
- Describe and calculate the internal and external loads which are considered when calculating the burst and collapse loads on a casing.
- Describe the source of tensile loads on casing and the way in which they combine during installation, cementing and production operations
- Describe the Bi-axial and tri-axial loads which the casing will be subjected to and the way in which these loads are accommodated in the design process.

1. INTRODUCTION

It is generally not possible to drill a well through all of the formations from surface (or the seabed) to the target depth in one hole section. The well is therefore drilled in sections, with each section of the well being sealed off by lining the inside of the borehole with steel pipe, known as **casing** and filling the annular space between this casing string and the borehole with cement, before drilling the subsequent hole section. This **casing string** is made up of joints of pipe, of approximately 40ft in length, with threaded connections. Depending on the conditions encountered, 3 or 4 casing strings may be required to reach the target depth. The cost of the casing can therefore constitute 20-30% of the total cost of the well (£1-3m). Great care must therefore be taken when designing a casing programme which will meet the requirements of the well.

There are many reasons for **casing off** formations:

- To prevent unstable formations from caving in;
- To protect weak formations from the high mudweights that may be required in subsequent hole sections. These high mudweights may fracture the weaker zones;
- To isolate zones with abnormally high pore pressure from deeper zones which may be normally pressured;
- To seal off lost circulation zones;
- When set across the production interval: to allow selective access for production / injection/control the flow of fluids from, or into, the reservoir(s).

One of the casing strings will also be required:

- To provide structural support for the wellhead and BOPs.

Each string of casing must be carefully designed to withstand the **anticipated loads** to which it will be exposed during installation, when drilling the next hole section, and when producing from the well. These loads will depend on parameters such as: the types of formation to be drilled; the formation pore pressures; the formation fracture pressures; the geothermal temperature profile; and the nature of the fluids in the formations which will be encountered. The designer must also bear in mind the costs of the casing, the availability of different casing types and the operational problems in running the casing string into the borehole.

Since the cost of the casing can represent up to 30% of the total cost of the well, the number of casing strings run into the well should be minimised. Ideally the drilling engineer would drill from surface to the target depth without setting casing at all. However, it is normally the case that several casing strings will have to be run into the well in order to reach the objective formations. These strings must be run concentrically with the largest diameter casing being run first and smaller casing strings being used as the well gets deeper. The sizes and setting depths of these casing strings depends almost entirely on the geological and pore pressure conditions in the particular location in which the well is being drilled. Some typical **casing string configurations** used throughout the world are shown in Figure 1.



In view of the high cost of casing, each string must be carefully designed. This design will be based on the **anticipated loads** to which the casing will be exposed. When drilling a development well, these loads will have been encountered in previous wells and so the casing programme can be designed with a high degree of confidence, and minimal cost. In an exploration well, however, these loads can only be estimated and problems may be encountered which were not expected. The casing design must therefore be more conservative and include a higher safety margin when quantifying the design loads for which the casing must be designed. In addition, in the case of an exploration well, the casing configuration should be flexible enough to allow an extra string of casing to be run, if necessary. A well drilled in an area with high pressures or troublesome formations will usually require more casing strings than one in a normally pressured environment (Figure 2).

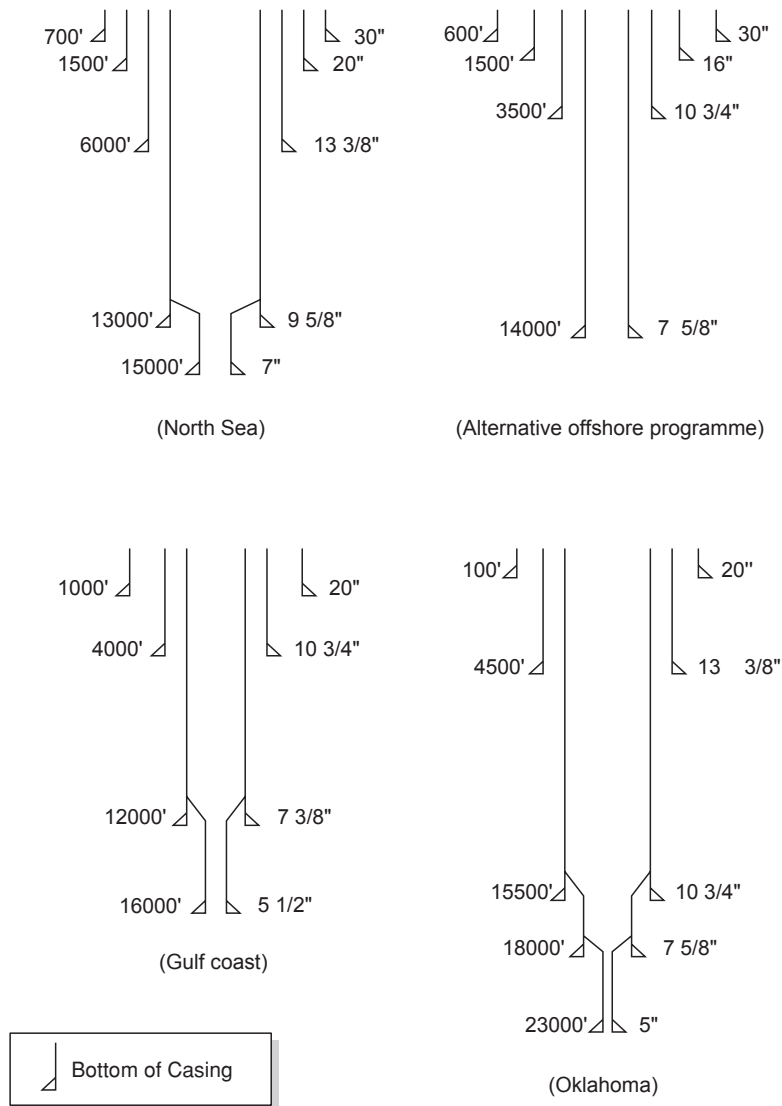

Figure 1 Casing string configurations

2. COMPONENT PARTS OF A CASING STRING

A **casing string** consists of individual **joints** of steel pipe which are connected together by threaded connections. The joints of casing in a string generally have the same outer diameter and are approximately 40ft long. A bull-nose shaped device, known as a **guide shoe or casing shoe**, is attached to the bottom of the casing string and a **casing hanger**, which allows the casing to be suspended from the wellhead, is attached to the top of the casing. Various other items of equipment, associated with the cementing operation, may also be included in the casing string, or attached to the outside of the casing e.g. float collar, centralisers and scratchers. This equipment will be discussed in greater depth in the chapter associated with cementing.

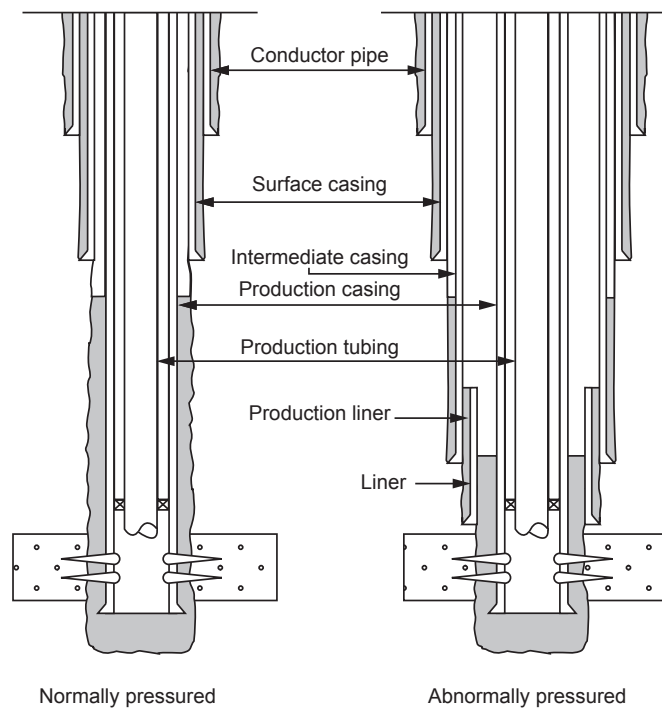

Figure 2 Casing string terminology

3. CASING TERMINOLOGY

There are a set of generic terms used to describe casing strings. These terms are shown in Figure 2. The classification system is based on the specific function of the casing string so, for instance, the function of the **surface string** shown in Figure 2 is to support the wellhead and BOP stack. Although there is no direct relationship between the size of casing and its function, there is a great deal of similarity in the casing sizes used by operators in the North Sea. The chart in Figure 3 shows the most common casing size and hole size configurations. The dotted lines represent less commonly used configurations. The terms which are generally used to classify casing strings are shown below. The casing sizes shown alongside the casing designation are those that are generally used in the North Sea.



3.1 Conductor Casing (30" O.D.)

The conductor is the first casing string to be run, and consequently has the largest diameter. It is generally set at approximately 100ft below the ground level or seabed. Its function is to seal off unconsolidated formations at shallow depths which, with continuous mud circulation, would be washed away. The surface formations may also have low fracture strengths which could easily be exceeded by the hydrostatic pressure exerted by the drilling fluid when drilling a deeper section of the hole. In areas where the surface formations are stronger and less likely to be eroded the conductor pipe may not be necessary. Where conditions are favourable the conductor may be driven into the formation and in this case the conductor is referred to as a **stove pipe**.

3.2 Surface Casing (20" O.D.)

The surface casing is run after the conductor and is generally set at approximately 1000 - 1500 ft below the ground level or the seabed. The main functions of surface casing are to seal off any fresh water sands, and support the wellhead and BOP equipment. The setting depth of this casing string is important in an area where abnormally high pressures are expected. If the casing is set too high, the formations below the casing may not have sufficient strength to allow the well to be shut-in and killed if a gas influx occurs when drilling the next hole section. This can result in the formations around the casing cratering and the influx flowing to surface around the outside of the casing.

3.3 Intermediate Casing (13 3/8" O.D.)

Intermediate (or protection) casing strings are used to isolate troublesome formations between the surface casing setting depth and the production casing setting depth. The types of problems encountered in this interval include: unstable shales, lost circulation zones, abnormally pressured zones and squeezing salts. The number of intermediate casing strings will depend on the number of such problems encountered.

3.4 Production Casing (9 5/8" O.D.)

The production casing is either run through the pay zone, or set just above the pay zone (for an open hole completion or prior to running a liner). The main purpose of this casing is to isolate the production interval from other formations (e.g. water bearing sands) and/or act as a conduit for the production tubing. Since it forms the conduit for the well completion, it should be thoroughly pressure tested before running the completion.

3.5 Liner (7" O.D.)

A liner is a short (usually less than 5000ft) casing string which is suspended from the inside of the previous casing string by a device known as a **liner hanger**. The liner hanger is attached to the top joint of the casing in the string. The liner hanger consists of a collar which has hydraulically or mechanically set slips (teeth) which, when activated, grip the inside of the previous string of casing. These slips support the weight of the liner and therefore the liner does not have to extend back up to the wellhead. The overlap with the previous casing (**liner lap**) is usually 200ft - 400ft. Liners may be used as an intermediate string or as a production string.

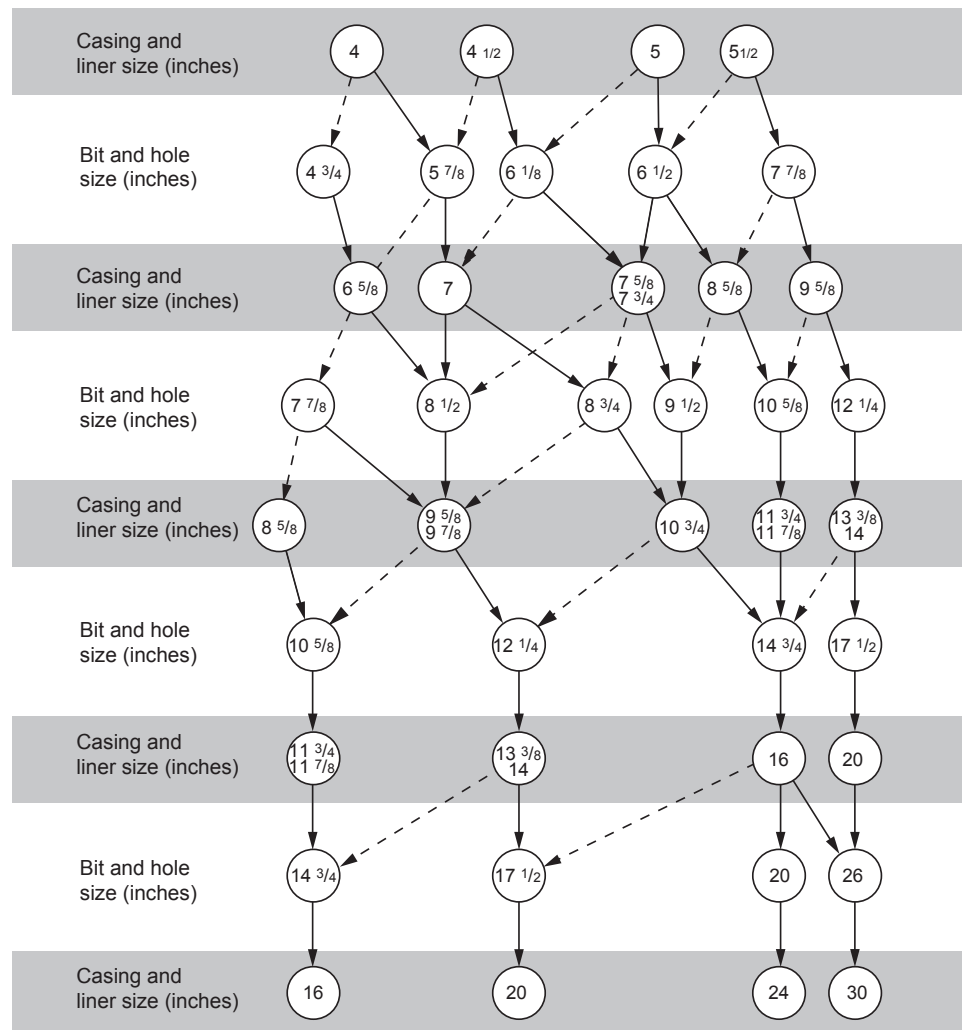

Figure 3 Casing string sizes

The advantages of running a liner, as opposed to a full string of casing, are that:

- A shorter length of casing string is required, and this results in a significant cost reduction;
- The liner is run on drillpipe, and therefore less rig time is required to run the string;
- The liner can be rotated during cementing operations. This will significantly improve the mud displacement process and the quality of the cement job.

After the liner has been run and cemented it may be necessary to run a casing string of the same diameter as the liner and connect onto the top of the liner hanger, effectively extending the liner back to surface. The casing string which is latched onto the top of the liner hanger is called a **tie-back string**. This tie-back string may be required to protect the previous casing string from the pressures that will be encountered when the well is in production.



In addition to being used as part of a production string, liners may also be used as an intermediate string to case off problem zones before reaching the production zone. In this case the liner would be known as a **drilling liner** (Figure 2). Liners may also be used as a patch over existing casing for repairing damaged casing or for extra protection against corrosion. In this case the liner is known as a **stub liner**.

4. PROPERTIES OF CASING

When the casing configuration (casing size and setting depth) has been selected, the loads to which each string will be exposed will be computed. Casing, of the required size, and with adequate load bearing capacity will then be selected from manufacturer's catalogues or cementing company handbooks.

Casing joints are manufactured in a wide variety of sizes, weights and material grades and a number of different types of connection are available. The detailed specification of the sizes, weights and grades of casing which are most commonly used has been standardised by the American Petroleum Institute - API. The majority of sizes, weights and grades of casing which are available can be found in manufacturer's catalogues and cementing company handbooks (e.g. Halliburton Cementing Tables).

Casing is generally classified, in manufacturer's catalogues and handbooks, in terms of its size (O.D.), weight, grade and connection type:

4.1 Casing Size (Outside Diameter - O.D.)

The *size* of the casing refers to the outside diameter (O.D.) of the main body of the tubular (not the connector). Casing sizes vary from 4.5" to 36" diameter. Tubulars with an O.D. of less than 4.5" are called **Tubing**. The sizes of casing used for a particular well will generally be limited to the standard sizes that are shown in Figure 3. The hole sizes required to accommodate these casing sizes are also shown in this diagram. The casing string configuration used in any given location e.g. 20" x 13 3/8" x 9 5/8" x 7" x 4 1/2" is generally the result of local convention, and the availability of particular sizes.

4.2 Length of Joint

The length of a joint of casing has been standardised and classified by the API as follows:

Range	Length (ft.)	Average Length (ft.)
1	16-25	22
2	25-34	31
3	34+	42

Table 1 API length ranges

Although casing must meet the classification requirements of the API, set out above, it is not possible to manufacture it to a precise length. Therefore, when the casing is delivered to the rig, the precise length of each joint has to be measured and recorded on a **tally sheet**. The length is measured from the top of the connector to a reference point on the pin end of the connection at the far end of the casing joint. Lengths are recorded on the tally sheet to the nearest 100th of a foot. Range 2 is the most common length, although shorter lengths are useful as **pup joints** when attempting to assemble a precise length of string.

4.3 Casing Weight

For each casing size there are a range of **casing weights** available. The weight of the casing is in fact the weight per foot of the casing and is a representation of the wall thickness of the pipe. There are for instance four different weights of 9 5/8" casing:

Weight lb/ft	OD in.	ID in.	Wall Thickness in.	Drift Diameter in.
53.5	9.625	8.535	0.545	8.379
47	9.625	8.681	0.472	8.525
43.5	9.625	8.755	0.435	8.599
40	9.625	8.835	0.395	8.679

Table 2 9 5/8" Casing weights

Although there are strict tolerances on the dimensions of casing, set out by the API, the actual I.D. of the casing will vary slightly in the manufacturing process. For this reason the **drift diameter** of casing is quoted in the specifications for all casing. The drift diameter refers to the guaranteed minimum I.D. of the casing. This may be important when deciding whether certain drilling or completion tools will be able to pass through the casing e.g. the drift diameter of 9 5/8" 53.5 lb/ft casing is less than 8 1/2" bit and therefore an 8 1/2" bit cannot be used below this casing setting depth. If the 47 lb/ft casing is too weak for the particular application then a higher grade of casing would be used (see below). The nominal I.D. of the casing is used for calculating the volumetric capacity of the casing.

4.4 Casing Grade

The chemical composition of casing varies widely, and a variety of compositions and treatment processes are used during the manufacturing process. This means that the physical properties of the steel varies widely. The materials which result from the manufacturing process have been classified by the API into a series of "grades" (Table 3). Each grade is designated by a letter, and a number. The letter refers to the chemical composition of the material and the number refers to the minimum yield strength of the material e.g. N-80 casing has a minimum yield strength of 80000 psi and K-55 has a minimum yield strength of 55000 psi. Hence the grade of the casing provides an indication of the strength of the casing. The higher the grade, the higher the strength of the casing.



In addition to the API grades, certain manufacturers produce their own grades of material. Both seamless and welded tubulars are used as casing although seamless casing is the most common type of casing and only H and J grades are welded.

Grade	Yield Strength (psi)		Tensile Strength (psi)
	min.	max.	
H-40	40000	-	60000
J-55	55000	80000	75000
K-55	55000	80000	95000
C-75	75000	90000	95000
L-80	80000	95000	95000
N-80	80000	110000	100000
S-95*	95000	-	110000
P-110	110000	140000	125000
V-150*	150000	180000	160000

Table 3 Casing grades and properties

4.5 Connections

Individual joints of casing are connected together by a threaded connection. These connections are variously classified as: **API; premium; gastight; and metal-to-metal seal.** In the case of API connections, the casing joints are threaded externally at either end and each joint is connected to the next joint by a coupling which is threaded internally (Figure 5). A coupling is already installed on one end of each joint when the casing is delivered to the rig. The connection must be leak proof but can have a higher or lower physical strength than the main body of the casing joint. A wide variety of threaded connections are available. The standard types of API threaded and coupled connection are:

- Short thread connection (STC)
- Long thread connection (LTC)
- Buttress thread connection (BTC)

In addition to threaded and coupled connections there are also externally and internally upset connections such as that shown in Figure 4. A standard API upset connection is:

- Extreme line (EL)

The STC thread profile is rounded with 8 threads per inch. The LTC is similar but with a longer coupling, which provides better strength and sealing properties than the STC. The buttress thread profile has flat crests, with the front and back cut at different angles. Extreme line connections also have flat crests and have 5 or 6 threads per inch. The EL connection is the only API connection that has a metal to

metal seal at the end of the pin and at the external shoulder of the connection, whereas all of the other API connections rely upon the thread compound, used to make up the connection, to seal off the leak path between the threads of the connection.

In addition to API connections, various manufacturers have developed and patented their own connections (e.g. Hydril, Vallourec, Mannesman). These connections are designed to contain high pressure gas and are often called **gastight, premium** and **metal-to-metal seal** connections. These connections are termed metal-to-metal seal because they have a specific surface machined into both the pin and box of the connection which are brought together and subjected to stress when the connection is made up.

Surveys have shown that over 80% of leaks in casing can be attributed to poor make-up of connections. This may be due to a variety of reasons:

- Excessive torque used in making-up the connections
- Dirty threads
- Cross-threading
- Using the wrong thread compound.

The casing string should be tested for pressure integrity before drilling the subsequent hole section. Most of the causes of connection failure can be eliminated by good handling and running procedures on the rig.

The recommended make-up torque for API connections is given in API RP 5C1. These recommended torques are based on an empirical equation obtained from tests using API modified thread compound on API connections. The recommended make up torque for other connections is available from manufacturers.

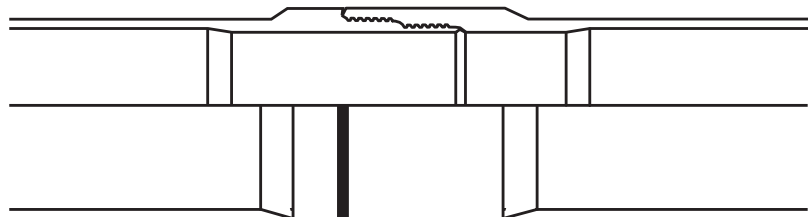

Figure 4 Externally and internally upset casing connection

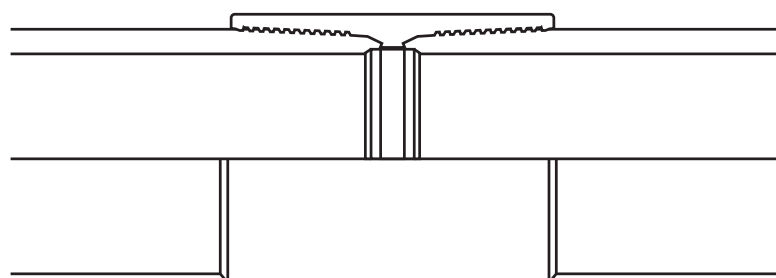

Figure 5 Threaded and coupled connection



5. API SPECIFICATIONS, STANDARDS AND BULLETINS

The API Committee responsible for the Standardisation of tubular goods is Committee number 5. This committee publishes, and continually updates, a series of Specifications, Standards, Bulletins and Recommended Practices covering the manufacture, performance and handling of tubular goods. The documents, published by Committee 5, of particular relevance to casing design and specification are :

API SPEC 5CT, “Specification for casing a tubing”: Covers seamless and welded casing and tubing, couplings, pup joints and connectors in all grades. Processes of manufacture, chemical and mechanical property requirements, methods of test and dimensions are included.

API STD 5B, “Specification for threading, gauging, and thread inspection for casing, tubing, and line pipe threads”: Covers dimensional requirements on threads and thread gauges, stipulations on gauging practice, gauge specifications and certifications, as well as instruments and methods for the inspection of threads of round-thread casing and tubing, buttress thread casing, and extreme-line casing and drill pipe.

API RP 5A5, “Recommended practice for field inspection of new casing, tubing and plain-end drill pipe”: Provides a uniform method of inspecting tubular goods.

API RP 5B1, “Recommended practice for thread inspection on casing, tubing and line pipe”: The purpose of this recommended practice is to provide guidance and instructions on the correct use of thread inspection techniques and equipment.

API RP 5C1, “Recommended practice for care and use of casing and tubing”: Covers use, transportation, storage, handling, and reconditioning of casing and tubing.

API RP 5C5, “Recommended practice for evaluation procedures for casing and tubing connections”: Describes tests to be performed to determine the galling tendency, sealing performance and structural integrity of tubular connections.

API BULL 5A2, “Bulletin on thread compounds”: Provides material requirements and performance tests for two grades of thread compound for use on oil-field tubular goods.

API BULL 5C2, “Bulletin on performance properties of casing and tubing”: Covers collapsing pressures, internal yield pressures and joint strengths of casing and tubing and minimum yield load for drill pipe.

API BULL 5C3, “Bulletin on formulas and calculations for casing, tubing, drillpipe and line pipe properties”: Provides formulas used in the calculations of various pipe properties, also background information regarding their development and use.

API BULL 5C4, “Bulletin on round thread casing joint strength with combined internal pressure and bending.”: Provides joint strength of round thread casing when subject to combined bending and internal pressure.

6. WELLHEADS AND CASING HANGERS

All casing strings, except for liners, are suspended from a wellhead. On a land well or offshore platform the wellhead is just below the rig floor. When drilling offshore, from a floating vessel, the wellhead is installed at the seabed. These **subsea wellheads** will be discussed in the chapter relating to Subsea Drilling. The wellhead on a land or platform well is made up of a series of *spools*, stacked up, one on top of the other (Figure 6). Surface wellhead spools have four functions:

- To suspend the weight of the casing string;
- To seal off the annulus between successive casing strings at the surface;
- To allow access to the annulus between casing strings;
- To act as an interface between the casing string and BOP stack.

When the casing string has been run into the wellbore it is hung off, or suspended, by a **casing hanger**, which rests on a landing shoulder inside the **casing spool**. Casing hangers must be designed to take the full weight of the casing, and provide a seal between the casing hanger and the spool. There are two types of surface wellhead in common use:

6.1 Spool Type Wellhead

The procedure for installing a spool type wellhead system (Figure 6) can be outlined as follows:

- (a) The conductor (30") is run and cemented in place. It is then cut off just above the ground level or the wellhead deck (on a platform);
- (b) The 26" hole is drilled and the 20" casing is run through the conductor and cemented. Sometimes a landing base is welded onto the top of the 20" casing so that it can rest on the top of the 30" conductor, to transfer some weight to the 30" casing.
- (c) The 20" casing is cut off just above the 30" casing and a 20" **casing head housing** (lowermost casing head) is threaded, or welded, onto the top of the casing. The internal profile of this housing has a landing surface on which the casing hanger of the subsequent casing string (13 3/8") lands. The housing has two side outlets which provide access to the 20"x13 3/8" annulus. The upper flange of the housing is used as the lower part of the connection to the BOP stack used in drilling the next hole section. A ring gasket is used to seal off the connection between the housing and the BOP stack.
- (d) The 17 1/2" hole is drilled and the 13 3/8" casing is run with the hanger landing in the 20" housing. The casing is cemented in place. The BOP stack is disconnected and a **casing spool** (13 5/8") is flanged up on top of the 20" housing. The BOPs are made up on top of the 13 5/8" spool and the 12 1/4" hole is drilled.

The process continues, with a new spool being installed for each casing string. Eventually a tubing head spool is installed. This spool allows the completion tubing to be suspended from the wellhead. The minimum I.D. of a casing spool must be

greater than the drift I.D. of the previous casing. A protective sleeve known as a **wear bushing** is installed in each spool when it is installed and before the drillstring is run. The wear bushing must be removed before the next casing string is run.

Finally the Christmas tree is installed on top of the wellhead (Figure 7). A ring gasket, approved by the API, is used to seal off the space between the flanges on the spools. The gaskets have pressure energized seals and can be rated up to 15000 psi.

The disadvantages of this type of wellhead are:

- a lot of time is spent flanging up the spools;
- the large number of seals, increases the chance of a pressure leak;
- BOPs must be removed to install the next casing spool;
- a lot of headroom is required, which may not be available in the wellhead area of an offshore platform.

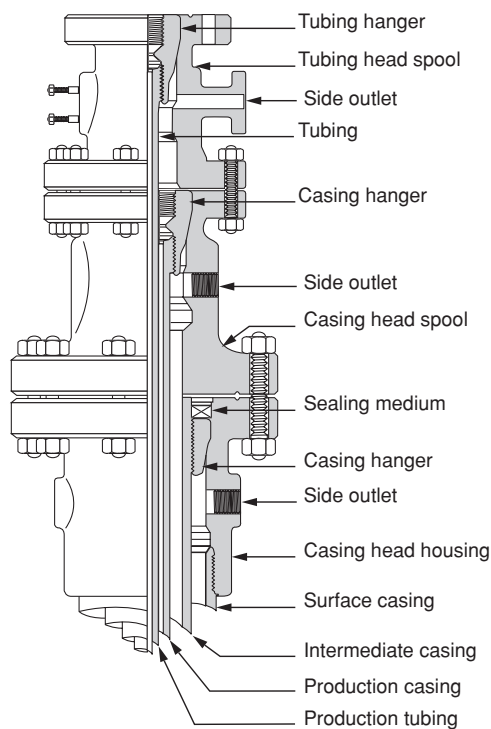

Figure 6 API Wellhead

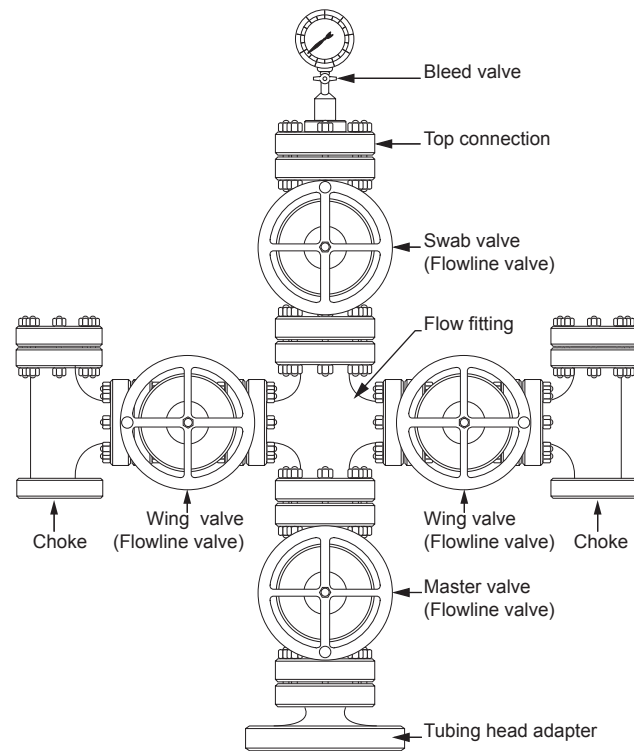

Figure 7 Conventional Xmas Tree

6.2 Compact Spool (Speedhead)

The compact spool was developed as an alternative to the conventional spool discussed above. A compact spool enables several casing strings or tubing to be suspended from a single spool. The first step in using this type of wellhead is to install the 20" casing head housing, as in the case of the spool type wellhead. After the 13 3/8" casing is run and cemented, the casing is cut off and the speedhead is connected to the casing head housing. The BOPs can then be connected to the top of the housing, and the next hole section drilled.

The 9 5/8" casing is then run, with the hanger resting on a landing shoulder inside the speedhead. A 7" casing string can be run, and landed, in the speedhead in a similar manner to the 9 5/8" casing. The tubing string may also be run and landed in the speedhead. The Christmas tree can then be installed on top of the speedhead.

The disadvantage of the compact spool is that the casing programme cannot be easily altered, and so this system is less flexible than the separate spool system.

6.3 Casing Hangers

There are two types of casing hanger in common use. Wellheads can be designed to accept both types of hanger.

Mandrel (boll weevil) Type Casing Hangers: This type of hanger (Figure 8) is screwed onto the top of the casing string so that it lands in the casing housing when the casing shoe reaches the required depth. Short lengths of casing, known as pup joints may have to be added to the string so that the casing shoe is at the correct

depth when the hanger lands in the wellhead. The calculation which determines the length of pup joints required to achieve this positioning is known as **spacing out** the string. Although this is the most common type of hanger it cannot be used if there is a risk that the casing will not reach bottom and therefore that the hanger will not land in the wellhead.

Slip Type Casing Hangers: This type of hanger (Figure 9) is wrapped around the casing and then lowered until it sits inside the casing spool. The slips are automatically set when the casing is lowered (in a similar fashion to drillpipe slips) This type of hanger can be used if the casing stands up on a ledge and cannot reach its required setting depth. These types of hanger are also used when tension has to be applied in order to avoid casing buckling when the well is brought into production.

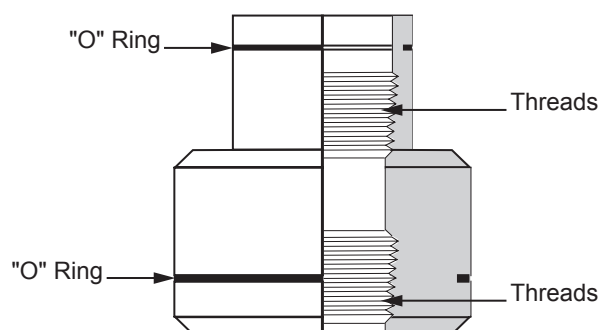

Figure 8 Mandrel or Boll-Weevil type casing hanger

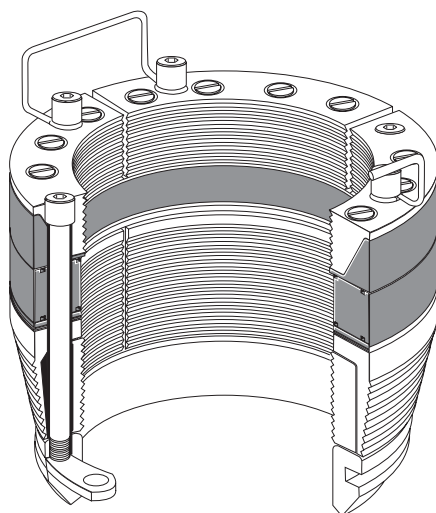

Figure 9 Slip type casing hanger

7. RIG-SITE OPERATIONS

Casing leaks are often caused by damaging the threads while handling and running the casing on the rig. It has also been known for a joint of the wrong weight or grade of casing to be run in the wrong place, thus creating a weak spot in the string. Such mistakes are usually very expensive to repair, both in terms of rig time and

materials. It is important, therefore, to use the correct procedures when running the casing.

7.1 Handling Procedures

(a) When the casing arrives at the rig site the casing should be carefully stacked in the correct running order. This is especially important when the string contains sections of different casing grades and weights. On offshore rigs, where deck space is limited, do not stack the casing too high or else excessive lateral loads will be imposed on the lowermost row. Casing is off-loaded from the supply boat in reverse order, so that it is stacked in the correct running order

(b) The length, grade, weight and connection of each joint should be checked and each joint should be clearly numbered with paint. The length of each joint of casing is recorded on a **tally sheet**. If any joint is found to have damaged threads it can be crossed off the tally sheet. The tally sheet is used by the Drilling engineer to select those joints that must be run so that the casing shoe ends up at the correct depth when the casing hanger is landed in the wellhead.

(c) While the casing is on the racks the threads and couplings should be thoroughly checked and cleaned. Any loose couplings should be tightened

(d) Casing should always be handled with thread protectors in place. These need not be removed until the joint is ready to be stabbed into the string.

7.2 Casing Running Procedures

(a) Before the casing is run, a check trip should be made to ensure that there are no tight spots or ledges which may obstruct the casing and prevent it reaching bottom

(b) The drift I.D. of each joint should be checked before it is run.

(c) Joints are picked up from the catwalk and temporarily rested on the ramp. A single joint elevator is used to lift the joint up through the “V” door into the derrick (Figure 10).

(d) A service company (casing crew) is usually hired to provide a stabber and one or two floormen to operate the power tongs. The stabbing board is positioned at the correct height to allow the stabber to centralise the joint directly above the box of the joint suspended in the rotary table. The pin is then carefully stabbed into the box and the power tongs are used to make up the connection slowly to ensure that the threads of the casing are not cross threaded. Care should be taken to use the correct thread compound to give a good seal. The correct torque is also important and can be monitored from a torque gauge on the power tongs. On buttress casing there is a triangle stamped on the pin end as a reference mark. The coupling should be made up to the base of the triangle to indicate the correct make-up.

(e) As more joints are added to the string the increased weight may require the use of heavy duty slips (spider) and elevators (Figure 11).

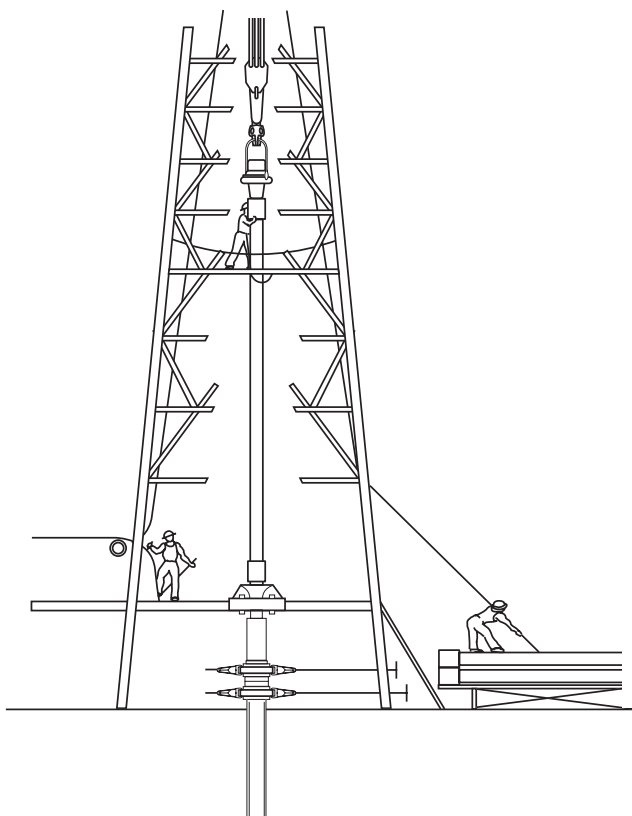
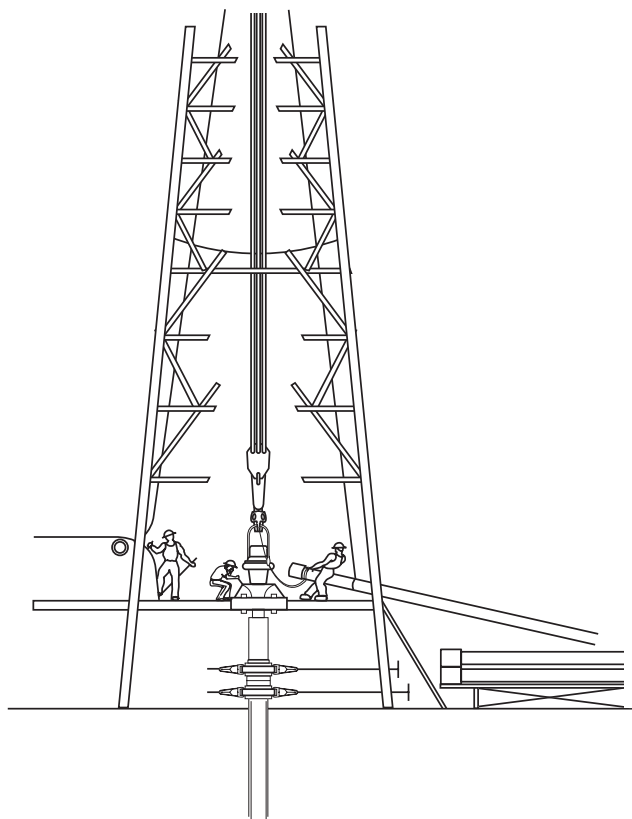

Figure 10 Casing running operations

(f) If the casing is run too quickly into the hole, surge pressures may be generated below the casing in the open hole, increasing the risk of formation fracture. A running speed of 1000 ft per hour is often used in open hole sections. If the casing is run with a float shoe the casing should be filled up regularly as it is run, or the casing will become buoyant and may even collapse, under the pressure from the mud in the hole.

(g) The casing shoe is usually set 10-30 ft off bottom.

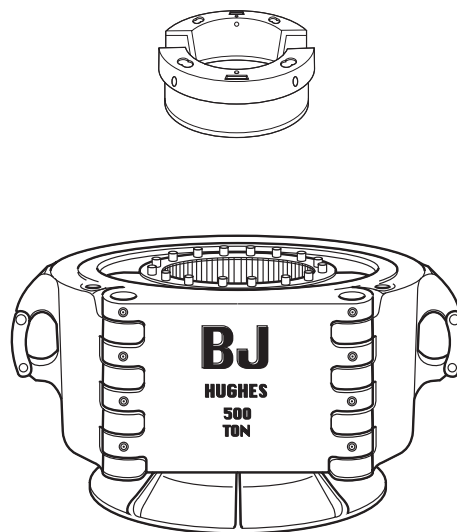

Figure 11 Heavy duty casing elevators

7.3 Casing Landing Procedures

After the casing is run to the required depth it is cemented in place while suspended in the wellhead. The method used for landing the casing will vary from area to area, depending on the forces exerted on the casing string after the well is completed. These forces may be due to changes in formation pressure, temperature, fluid density and earth movements (compaction). These will cause the casing to either shrink or expand, and the landing procedure must take account of this. There are basically 3 different ways in which the casing can be cemented and landed:

- landing the casing and cementing;
- suspending the casing, conducting the cement job and then applying additional tension when the cement has hardened;
- landing the casing under compression;

The first case does not require any action after the cementing operation is complete. The casing is simply landed on a boll-weevil hanger and cemented in place. Additional tension (over and above the suspended weight) may however have to be applied to the casing to prevent buckling due to thermal expansion when the well is producing hot fluids. Additional tension can be applied, after the casing has been cemented, by suspending the casing from the elevators during the cementing operation and then applying an **overpull** (extra tension) to the casing once the cement has hardened.

The casing would then be landed on a slip and seal assembly. The level of overpull applied to the casing will depend on the amount of buckling load that is anticipated due to production. The third option may be required in the case that the suspended tension reduces the casing's collapse resistance below an acceptable level. In this case the casing is suspended from the elevators during cementing and then lowered until the desired compression is achieved before setting the slip and seal assembly.

7.4 Liner Running Procedures

Liners are run on drillpipe with special tools which allow the liner to be run, set and cemented all in one trip (Figure 12). The liner hanger is installed at the top of the liner. The hanger has wedge slips which can be set against the inside of the previous string. The slips can be set mechanically (rotating the drillpipe) or hydraulically (differential pressure). A liner packer may be used at the top of the liner to seal off the annulus after the liner has been cemented. The basic liner running procedure is as follows:

- (a) Run the liner on drillpipe to the required depth;
- (b) Set the liner hanger;
- (c) Circulate drilling fluid to clean out the liner;
- (d) Back off (disconnect) the liner hanger setting tool;
- (e) Pump down and displace the cement;
- (f) Set the liner packer;
- (g) Pick up the setting tool, reverse circulate to clean out cement and pull out of hole.

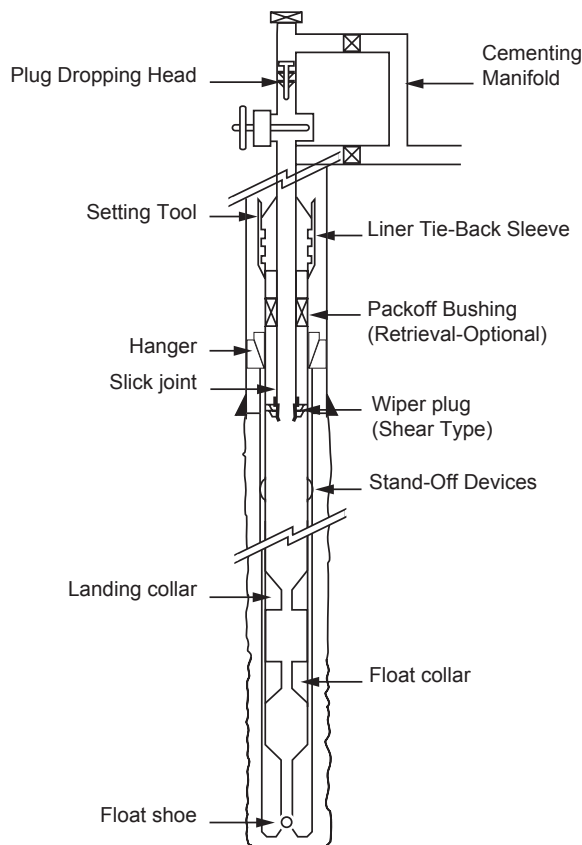

Figure 12 Casing liner equipment

8. CASING DESIGN

8.1 Introduction to the Casing Design Process

The casing design process involves three distinct operations: the selection of the casing sizes and setting depths; the definition of the operational scenarios which will result in burst, collapse and axial loads being applied to the casing; and finally the calculation of the magnitude of these loads and selection of an appropriate weight and grade of casing. The steps in the casing design process are shown in Figure 13.

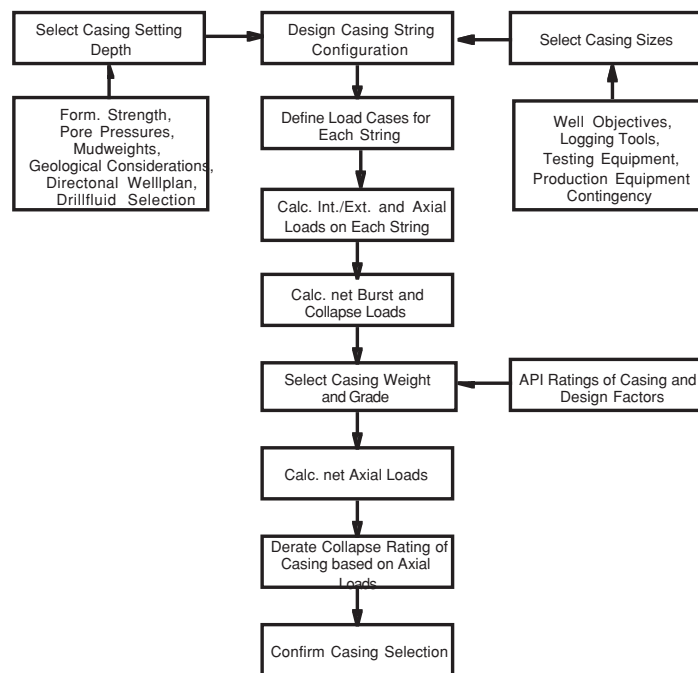

Figure 13 Casing design process

8.1.1 Design Casing Scheme Configuration - Select Casing sizes and Setting Depths

The casing *setting depths* are selected on the basis of an assessment of the conditions to be encountered when drilling the subsequent hole section or, in the case of production casing, the completion design.

The first step in deciding upon the setting depth for the surface and intermediate casing strings is to calculate the maximum pressures that could be encountered in the hole section below the string in question. These pressures must not exceed the formation strength at any point in the hole and in particular at the casing shoe. The highest pressure that will be encountered in the open hole section will occur when circulating out a gas influx (see chapter on Well Control). The formation strength can be estimated from nearby well data or by calculation (see chapter on Formation Pressures and Fracture Strength). The procedure for establishing the acceptable setting depth is illustrated in Figure 14:

1. Start at Total Depth (TD) of the Well
2. Determine the formation fracture pressure at all points in the well
3. Calculate the borehole pressure profile when circulating out a gas influx from TD
4. Plot the formation fracture pressure and the wellbore pressure when circulating out an influx, on the same axes
5. The casing must be set at least at the depth where the two plots cross i.e. this is the shallowest depth at which the casing can be safely set. If the casing is set any shallower when drilling this hole section then the formation will fracture if an influx occurs.
6. Repeat steps 2 to 5 moving up the well, with each subsequent string starting at the casing setting depth for each string.

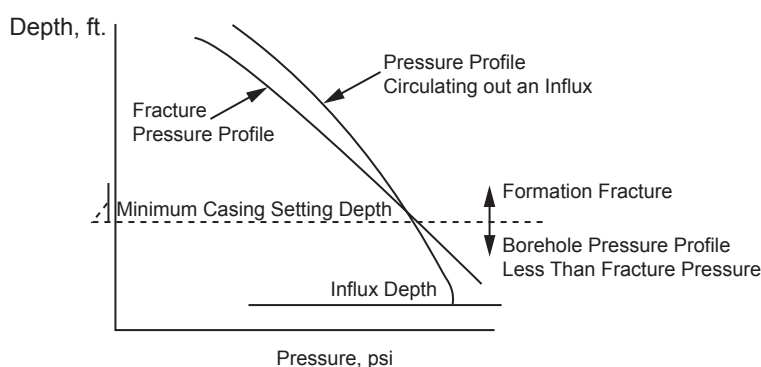

Figure 14 Casing setting depth determination

The setting depth of the casing will also be determined by a range of other considerations such as: the need to isolate weak formations from high mudweights; isolate lost circulation zones; and to isolate troublesome formations, such as shales, which can cause hole problems whilst drilling subsequent formations.

The casing *sizes* and string configuration are dictated by the size of the smallest casing string to be run in hole. Once the smallest casing size is known all subsequent casing sizes (and hole sizes) are selected from Figure 3. The smallest casing size is selected on the basis of operational considerations such as: the size and configuration of the completion string or well testing and/or the size of the logging tools to be run through the casing. The drilling engineer will collate this information from the geology, reservoir engineering and production engineering departments. The objective of the drilling engineer is to use the smallest casing sizes possible. It can be readily appreciated that if it is acceptable to use a 4" casing string as the production casing then the next string will be 7", the next 9 5/8" and so forth. Hence, if only three casing strings are required then the surface string can be 9 5/8". This slimhole design will result in considerable savings in drilling and equipment costs.

8.1.2 Define the Operational Scenarios and Consequent Loads on the Casing

The loads to which the casing will be exposed during the life of the well will depend on the operations to be conducted: whilst running the casing; drilling the subsequent hole section; and during the producing life of the well. These operations will result in **radial (burst and collapse) and axial (tensile and compressive) loads** on the casing strings. Since the operations conducted inside any particular string (e.g. the surface string) will differ from those inside the other strings (e.g. the production string) the load scenarios and consequent loads will be specific to a particular string. The definition of the operational scenarios to be considered is one of the most important steps in the casing design process and they will therefore generally be established as a company policy.

8.1.3 Calculate the Loads on the Casing and Select the Appropriate Weight and Grade of Casing

Having defined the size and setting depth for the casing strings, and defined the operational scenarios to be considered, the loads to which the casing will be exposed can be computed. The particular weight and grade of casing required to withstand these loads can then be determined.

The **uniaxial** loads to which the casing is exposed are:

Collapse Load

The casing will experience a net collapse loading if the external radial load exceeds the internal radial load (Figure 15). The greatest collapse load on the casing will occur if the casing is evacuated (empty) for any reason. The collapse load, P_c at any point along the casing can be calculated from:

$$P_c = P_e - P_i$$

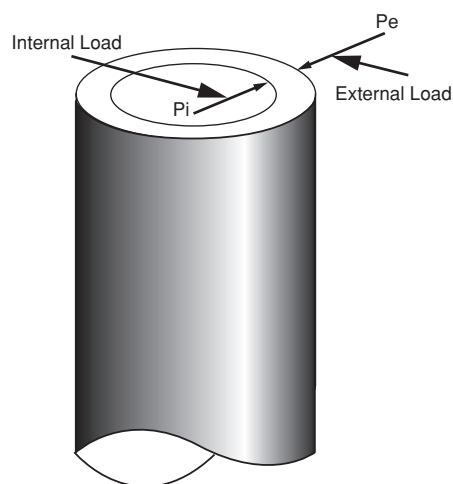

Figure 15 Radial loads on casing



Burst Load

The casing will experience a net burst loading if the internal radial load exceeds the external radial load. The burst load, P_b at any point along the casing can be calculated from:

$$P_b = P_i - P_e$$

In designing the casing to resist burst loading the pressure rating of the wellhead and BOP stack should be considered since the casing is part of the well control system.

The internal, P_i and external, P_e loads which are used in the determination of the burst and collapse loads on the casing are derived from an analysis of operational scenarios.

External Loads, P_e :

The following issues are considered when deciding upon the external load to which the casing will be subjected:

(a.) The pore pressure in the formation (pore pressure)

If the engineer is satisfied that it will be possible to displace all of the mud from the annulus between the casing and borehole during the cementing operation, and that a satisfactory cement sheath can be achieved, the formation pore pressure is generally used to determine the load acting on the casing below the top of cement in the annulus, after the cement has hardened.

(b.) The weight of the mud in which the casing was run.

If a poor cement bond between the casing and cement or cement and borehole is anticipated then the pressure due to a column of mud in the annulus is generally used to determine the load acting on the casing below the top of cement in the annulus, after the cement has hardened. If the mud has been in place for more than 1 year the weighting material will probably have settled out and therefore the pressure experienced by the casing will be due to a column of mud mixwater (water or base-oil).

(c.) The pressure from a column of cement mixwater

The pressure due to the cement mixwater is often used to determine the external load on the casing during the producing life of the well. This pressure is equal to the density of fresh or seawater in the case of water-based mud and base oil in the case of oil based mud. The assumption is that the weighting material in the mud (generally Barite) has settled from suspension.

(d.) The pressure due to a column of cement slurry

The pressure exerted by a column of cement slurry will be experienced by the casing until the cement sets. It is assumed that hardened cement does not exert a hydrostatic pressure on the casing.

(e.) Blockage in the annulus

If a blockage of the annulus occurs during a stinger cement operations (generally performed on a conductor casing). The excess pumping pressure on the cement

will be transmitted to the annulus but not to the inside of the casing. This will result in an additional external load during stinger cementing. In the case of conventional cementing operations a blockage in the annulus will result in an equal and opposite pressures inside and outside the casing.

Internal Loads, P_i :

It is commonplace to consider the internal loads due to the following:

(a.) Mud to Surface:

This will be the predominant internal pressure during drilling operations. The casing designer must consider the possibility that the density of the drilling fluid may change during the drilling operation, due to for instance lost circulation or an influx.

(b.) Pressure due to influx

The worst case scenario which can arise, from the point of view of burst loading, is if an influx of hydrocarbons occurs, that the well is completely evacuated to gas and simultaneously closed in at the BOP stack.

(c.) Full Evacuation

The worst case scenario which can arise, from the point of view of collapse loading, is if the casing is completely evacuated.

(d.) Production Tubing Leak

In the case of production casing specifically a leak in the production tubing will result in the tubing pressure being exposed to the casing. The closed in tubing pressure is used as the basis of determining the pressure on the casing. This is calculated on the basis of a column of gas against the formation pressure.

The pressure below surface is based on the combined effect of the tubing head pressure and the hydrostatic pressure due to a column of packer fluid (if there is any in the annulus).

(e.) Fracture Pressure of Open Formations

When considering the internal loads on a casing string the fracture pressure in any formations open to the internal pressures must be considered. The pressure in the open hole section cannot exceed the fracture pressure of the weakest formation. Hence, the pressures in the remaining portion of the borehole and the casing will be controlled by this fracture pressure. The formation just below the casing shoe is generally considered to be the weakest formation in the open hole section.

Net Radial Loading (Burst or Collapse Load)

When the internal and external loads have been quantified the maximum net radial loading on the casing is determined by quantifying the difference between the internal and external load at all points along the casing. If the net radial loading is outward then the casing is subjected to a burst load. If the net loading is inward then the casing is subjected to a collapse load. The internal and external loads used in the determination of the net load must be operationally compatible i.e. it must be possible for them to co-exist simultaneously.

Axial Load

The axial load on the casing can be either tensile or compressive, depending on the operating conditions (Figure 16). The axial load on the casing will vary along the length of the casing. The casing is subjected to a wide range of axial loads during installation and subsequent drilling and production. The axial loads which will arise during any particular operation must be computed and added together to determine the total axial load on the casing.

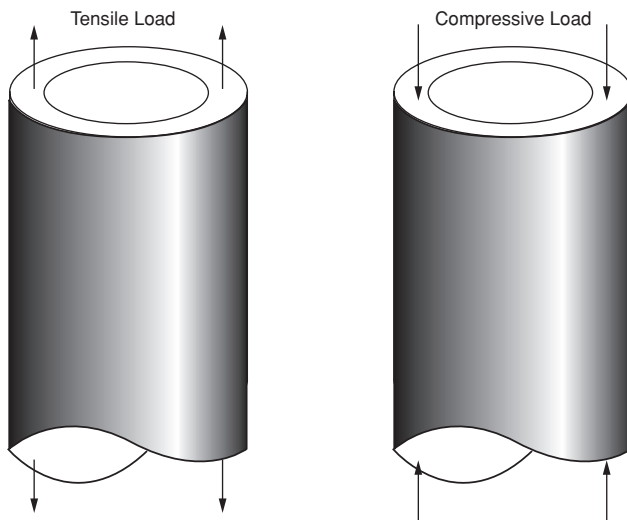

Figure 16 Axial Loads on Casing

The sources of axial loads on the casing are a function of a number of variables:

W	the dry weight of the casing;
ϕ	the angle of the borehole;
A_o	the cross sectional area of the outside of the casing;
A_i	the cross sectional area of the inside of the casing;
DLS	the dogleg severity of the well at any point;
P_i	the surface pressure applied to the I.D. of the casing;
A_s	the cross sectional area of the pipe body;
ΔT	the change in temperature at any point in the well ;
δP_i and $d\delta P_e$	the change in internal and external pressure on the casing; and
ν	the poissons ratio for the steel.

(a.) Dry weight of Casing (Fwt)

The suspension of a string of casing in a vertical or deviated well will result in an axial load. The total axial load on the casing (the weight of the casing) in air and can be computed from the following:

$$Fwt = W \cos \Phi$$

(b.) Buoyant Force on Casing (Fbuoy)

When submerged in a liquid the casing will be subjected to a compressive axial load. This is generally termed the buoyant force and can be computed from the following:

$$F_{buoy} = P_e (A_o - A_i) \quad \text{open ended casing}$$

$$F_{buoy} = P_e A_o - P_i A_i \quad \text{closed ended casing}$$

(c.) Bending Stress (F_{bend})

When designing a casing string in a deviated well the bending stresses must be considered. In sections of the hole where there are severe dog-legs (sharp bends) the bending stresses should be checked. The most critical sections are where dog-leg severity exceeds 10° per 100'. The axial load due to bending can be computed from the following:

$$F_{bend} = 64(DLS) OD (W)$$

(d.) Plug Bumping Pressure (F_{plug})

The casing will experience an axial load when the cement plug bumps during the cementation operation. This axial load can be computed from the following:

$$F_{plug} = P_{surf} A_i$$

(e.) Overpull when casing stuck (F_{pt})

If the casing becomes stuck when being run in hole it may be necessary to apply an overpull on the casing to get it free. This overpull can be added directly to the axial loads on the casing when it became stuck:

$$F_{pt} = \text{Direct tension}$$

(f.) Effects of Changes in Temperature (F_{temp})

When the well has started to produce the casing will be subjected to an increase in temperature and will therefore expand. Since the casing is restrained at surface in the wellhead and at depth by the hardened cement it will experience a compressive (buckling) load. The axial load generated by an increase in temperature can be computed by the following:

$$F_{temp} = -200 (A_s)(\Delta T)$$

(g.) Overpull to Overcome Buckling Forces (F_{op})

When the well has started to produce the casing will be subjected to compressive (buckling) loads due to the increase in temperature and therefore expansion of the casing. Attempts are often made to compensate for these buckling loads by applying an overpull to the casing when the cement in the annulus has hardened. This tensile load (the overpull) is 'locked into' the string by using the slip type hanger. The overpull is added directly to the axial load on the casing when the overpull is applied.

$$F_{op} = \text{Direct overpull}$$

(h.) Axial Force Due to Ballooning (During Pressure Testing) (F_{Bal})

If the casing is subjected to a pressure test it will tend to 'balloon'. Since the casing is restrained at surface in the wellhead and at depth by the hardened cement,



this ballooning will result in an axial load on the casing. This axial load can be computed from the following:

$$F_{Bal} = 2v(A_i \delta P_i - A_o \delta P_e)$$

(i.) Effect of Shock Loading (F_{shock})

Whenever the casing is accelerated or decelerated, being run in hole, it will experience a shock loading. This acceleration and deceleration occurs when setting or unsetting the casing slips or at the end of the stroke when the casing is being reciprocated during cementing operations. This shock loading can be computed from the following:

$$F_{shock} = 1780 v A_s$$

A velocity of 5cm/sec. is generally recommended for the computation of the shock loading.

During installation the total axial load F_t is some combination of the loads described above and depend on the operational scenarios. The objective is to determine the maximum axial load on the casing when all of the operational scenarios are considered.

Free Running of Casing:

$$F_t = F_{wt} - F_{buoy} + F_{bend}$$

Running Casing taking account of Shock Loading:

$$F_t = F_{wt} - F_{buoy} + F_{bend} + F_{shock}$$

Stuck Casing

$$F_t = F_{wt} - F_{buoy} + F_{bend} + F_{op}$$

Cementing Casing:

$$F_t = F_{wt} - F_{buoy} + F_{bend} + F_{plug} + F_{shock}$$

When cemented and additional overpull is applied ('As Cemented Base Case'):

$$F_{tbase} = F_{wt} - F_{buoy} + F_{bend} + F_{plug} + F_{pt}$$

During Drilling and Production the total axial load F_t is

$$F_t = F_{tbase} + F_{bal} + F_{temp}$$

Biaxial and Triaxial Loading

It can be demonstrated both theoretically and experimentally that the axial load on a casing can affect the burst and collapse ratings of that casing. This is represented in Figure 17. It can be seen that as the tensile load imposed on a tubular increases,

the collapse rating decreases and the burst rating increases. It can also be seen from this diagram that as the compressive loading increases the burst rating decreases and the collapse rating increases. The burst and collapse ratings for casing quoted by the API assume that the casing is experiencing zero axial load. However, since casing strings are very often subjected to a combination of tension and collapse loading simultaneously, the API has established a relationship between these loadings

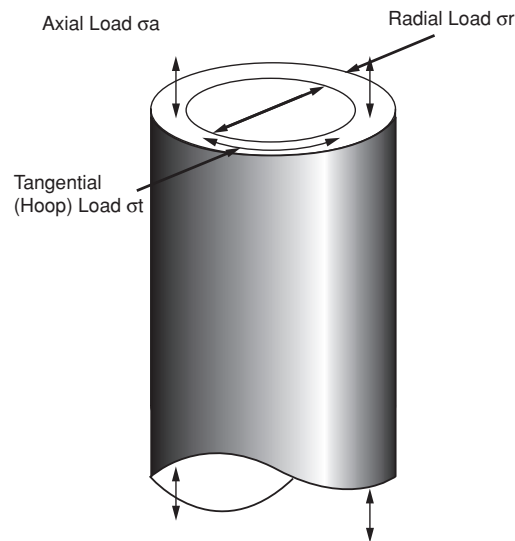

Figure 17 Tri-axial loading on casing

The Ellipse shown in Figure 18 is in fact a 2D representation of a 3D phenomenon. The casing will in reality experience a combination of three loads (Triaxial loading). These are Radial, Axial and Tangential loads (Figure 17). The latter being a resultant of the other two. Triaxial loading and failure of the casing due to the combination of these loads is very uncommon and therefore the computation of the triaxial loads on the casing are not frequently conducted. In the case of casing strings being run in extreme environment (>12,000 psi wells, high H2S) triaxial analysis should be conducted.

Design Factors

The uncertainty associated with the conditions used in the calculation of the external, internal, compressive and tensile loads described above is accommodated by increasing the burst collapse and axial loads by a **Design Factor**. These factors are applied to increase the actual loading figures to obtain the design loadings. Design factors are determined largely through experience, and are influenced by the consequences of a casing failure. The degree of uncertainty must also be considered (e.g. an exploration well may require higher design factors than a development well), The following ranges of factors are commonly used:

- Burst design factors 1.0 - 1.33
- Collapse design factors 1.0 - 1.125
- Tension design factors 1.0 - 2.0
- Triaxial Design Factors 1.25

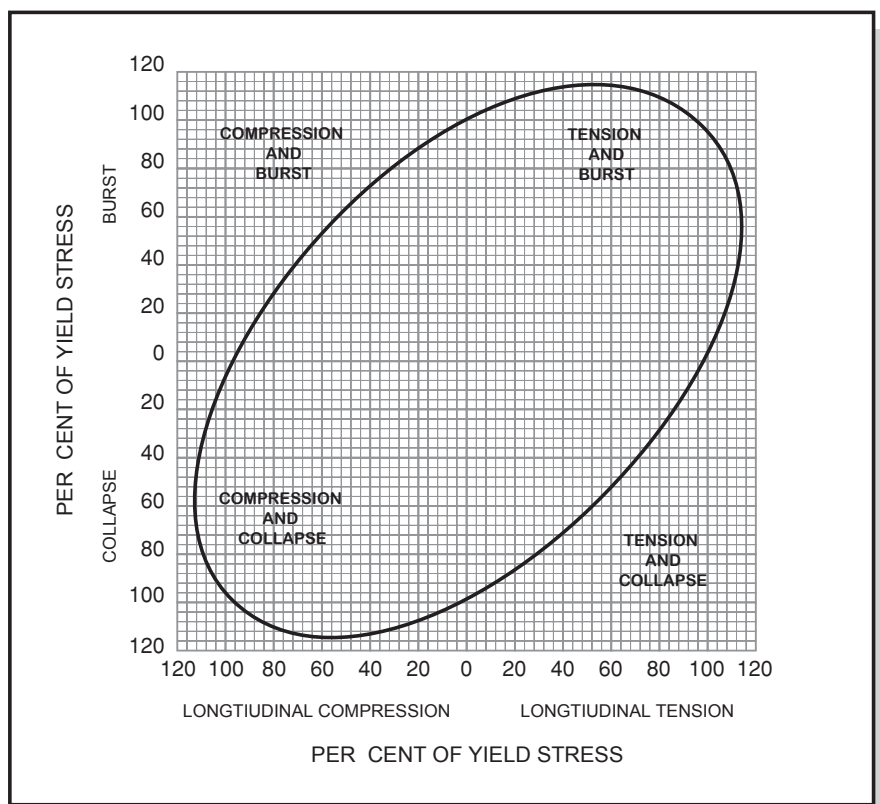

Figure 18 Tri-axial loading ellipse

8.2 Casing Design Rules Base

The loading scenarios to be used in the design of the casing string will be dictated by the operating company, on the basis of international and regional experience. These loading scenarios are generally classified on the basis of the casing string classification. The following rules base is presented as a typical example of a casing design rules base.

When the load case has been selected the internal and external loads are calculated on the basis of the rules below. These loads are then plotted on a common axis and the net loading (burst or collapse) is computed. An appropriate casing string can then be selected from the casing tables.

Conductor:

The predominant concern in terms of failure of the conductor casing during installation is collapse of the casing. Whilst running the casing it is highly unlikely that the casing will be subjected to a differential pressure. When conducting the cement job the inside of the casing will generally contain the drilling fluid in which the casing was run into the well. The maximum external load will be due to the borehole-casing annulus being full of cement (assumes cement to surface). If a stab-in stinger cementation job is conducted there is the possibility that the annulus will bridge off during the cementing operation and since this pressure will be isolated from the annulus between the casing and the drillpipe stinger this pressure will not

be experienced on the inside of the casing. Hence, very high collapse loads will be experienced by the casing below the point at which the bridging occurs.

The design scenario to be used for collapse of conductors in this course (and the examinations) is when the casing is fully evacuated due to lost circulation whilst drilling. In this case the casing is empty on the inside and the pore pressure is acting on the outside.

The maximum burst load is experienced if the well is closed in after a gas kick has been experienced. The pressure inside the casing is due to formation pore pressure at the bottom of the well and a colom of gas which extends from the bottom of the well to surface. It is assumed that pore pressure is acting on the outside of the casing.

Note that it would be very unusual to close a well in due to a "shallow" kick below the conductor. It would be more common to allow the influx to flow to surface and divert it away from the rig. This is to avoid the possibility of the formation below the shoe facturing.

OPERATION SCENARIO		LOAD CONDITION	INTERNAL LOAD	EXTERNAL LOAD
Installation - Burst and Collapse Load	1	Running Casing	Mud to Surface	Mud to Surface
	2	Conventional Cement Job	Mud to Surface	Cement Colom to surface
	3	Stinger Cement Job	Mud to Surface	Cement Colom to Surface
	4	Stab-in Cement Job	Mud to Surface	CementColom to surface plus bridging pressures in the annulus
Drilling - Burst Load	5	Burst Loads - Development Well	Pressure due to Full Colom of Gas on Pore Pressure at DSOH Depth	Pore Pressure
	6	Burst Load - Exploration Well	Pressure due to Full Colom of Gas on Pore Pressure at DSOH Depth	Pore Pressure
Drilling - Collapse Load	7	Collapse Load - Development Load	Full Evacuation of Casing	Pore Pressure
	8	Collapse Load - Exploration Load	Full Evacuation of Casing	Pore Pressure

Table 4 Casing design rules for conductors

Surface Casing:

Once the surface casing has been set a BOP stack will be placed on the wellhead and in the event of a kick the well will be closed in at surface and the kick circulated out of the well. The surface casing must therefore be able to withstand the burst loads which will result from this operation. Some operators will require that the casing be designed to withstand the burst pressures which would result from internal pressures due to full evacuation of the well to gas.



The maximum collapse loads may be experienced during the cement operation or due to lost circulation whilst drilling ahead.

The design scenario to be used for collapse of surface casing in this course (and the examinations) is when the casing is fully evacuated due to lost circulation whilst drilling. In this case the casing is empty on the inside and the pore pressure is acting on the outside.

The maximum burst load is experienced if the well is closed in after a gas kick has been experienced. The pressure inside the casing is due to formation pore pressure at the bottom of the well and a colom of gas which extends from the bottom of the well to surface. It is assumed that pore pressure is acting on the outside of the casing.

OPERATION SCENARIO		LOAD CONDITION	INTERNAL LOAD	EXTERNAL LOAD
Installation	1	Running Casing	Mud to Surface	Mud to Surface
	2	Conventional Cement Job	Mud to Surface	Cement Colom to surface
	3	Stinger Cement Job	Mud to Surface	Cement Colom to Surface
	4	Stab-in Cement Job	Mud to Surface	Cement Colom to surface plus bridging pressures in the annulus
Drilling - Burst Load	5	Burst Loads - Development Well	Pressure due to Full Colom of Gas on Pore Pressure at DSOH Depth	Pore Pressure
	6	Burst Load - Exploration Well	Pressure due to Full Colom of Gas on Pore Pressure at DSOH Depth	Pore Pressure
Drilling - Collapse Load	7	Collapse Load - Development Load	Full Evacuation of Casing	Pore Pressure
	8	Collapse Load - Exploration Load	Full Evacuation of Casing	Pore Pressure

Table 5 Casing design rules for surface casing

Intermediate Casing:

The intermediate casing is subjected to similar loads to the surface casing.

The design scenario to be used for collapse of intermediate casing in this course (and the examinations) is when the casing is fully evacuated due to lost circulation whilst drilling. In this case the casing is empty on the inside and the pore pressure is acting on the outside.

The maximum burst load is experienced if the well is closed in after a gas kick has been experienced. The pressure inside the casing is due to formation pore pressure at the bottom of the well and a colom of gas which extends from the bottom of the well to surface. It is assumed that pore pressure is acting on the outside of the casing.

OPERATION SCENARIO	LOAD CONDITION		INTERNAL LOAD	EXTERNAL LOAD
Installation	1	Running Casing	Mud to Surface	Mud to Surface
	2	Conventional Cement Job	Mud to Surface	Cement Colom to TOC and Mud/Spacer above TOC
Drilling - Burst Load	3	Burst Loads - Development Well	Pressure due to Full Colom of Gas on Pore Pressure at DSOH Depth	Pore Pressure
	4	Burst Load - Exploration Well	Pressure due to Full Colom of Gas on Pore Pressure at DSOH Depth	Pore Pressure
Drilling - Collapse Load	5	Collapse Load - Development Load	Full Evacuation of Casing	Pore Pressure
	6	Collapse Load - Exploration Load	Full Evacuation of Casing	Pore Pressure

Table 6 Casing design rules for intermediate casing

Production Casing:

The design scenarios for burst and collapse or the production casing are based on production operations.

The design scenario to be used for burst of production casing in this course (and the examinations) is when a leak is experienced in the tubing just below the tubing hanger. In this event the pressure at the top of the casing will be the result of the reservoir pressure minus the pressure due to a colom of gas. This pressure will the act on the fluid in the annulus of well and exert a very high internal pressure at the bottom of the casing.

The design scenario to be used for collapse of production casing in this course (and the examinations) is when the annulus between the tubing and casing has been evacuated due to say the use of gaslift.

8.3 Other design considerations

In the previous sections the general approach to casing design has been explained. However, there are special circumstances which cannot be satisfied by this general procedure. When dealing with these cases a careful evaluation must be made and the design procedure modified accordingly. These special circumstances include:

- Temperature effects - high temperatures will tend to expand the pipe, causing buckling. This must be considered in geothermal wells.



- Casing through salt zones - massive salt formations can flow under temperature and pressure. This will exert extra collapse pressure on the casing and cause it to shear. A collapse load of around 1 psi/ft (overburden stress) should be used for design purposes where such a formation is present.
- Casing through H₂S zones - if hydrogen sulphide is present in the formation it may cause casing failures due to hydrogen embrittlement.. L-80 grade casing is specially manufactured for use in H₂S zones.

OPERATION SCENARIO	LOAD CONDITION		INTERNAL LOAD	EXTERNAL LOAD
Installation	1	Running Casing	Mud to Surface	Mud to Surface
	2	Conventional Cement Job	Mud to Surface	Cement Colom to TOC and Mud/Spacer above TOC
Production - Burst Load	3	Burst Loads - Exploration and Development Well	At Surface: Pressure due to Colom of Gas on formation pressure at Producing Formation and At Top of Packer: Pressure due to Colom of Gas on formation pressure at Producing Formation acting on top of the packer fluid	Pore Pressure
Production - Collapse Load	4	Collapse Load - Exploration and Development Load	Full Evacuation of Casing down to packer	Pore Pressure

Table 7 Casing design rules for production casing

8.4 Summary of Design Process

The design process can be summarised as follows:

1. Select the Casing sizes and setting depths on the basis of: the geological and pore pressure prognosis provided by the geologist and reservoir engineer; and the production tubing requirements on the basis of the anticipated productivity of the formations to be penetrated.
2. Define the operational scenarios to be considered during the design of each of the casing strings. This should include installation, drilling and production (as appropriate) operations.
3. Calculate the burst loading on the particular casing under consideration.
4. Calculate the collapse loading on the particular casing under consideration.
5. Increase the calculated burst and collapse loads by the Design Factor which is appropriate to the casing type and load conditions considered.

6. Select the weight and grade of casing (from manufacturers tables or service company tables) which meets the load conditions calculated above.

7. For the casing chosen, calculate the axial loading on the casing. Apply the design factor for the casing and load conditions considered and check that the pipe body yield strength of the selected casing exceeds the axial design loading. Choose a coupling whose joint strength is greater than the design loading. Select the same type of coupling throughout the entire string.

8. Taking the actual tensile loading from ? above determine the reduction in collapse resistance at the top and bottom of the casing.

Several attempts may have to be made before all these loading criteria are satisfied and a final design is produced. When deciding on a final design bear the following points in mind:

- Include only those types of casing which you know are available. In practice only a few weights and grades will be kept in stock.
- Check that the final design meets all requirements and state clearly all design assumptions.
- If several different designs are possible, choose the most economical scheme that meets requirements.



Appendix 1 API Rated Capacity of Casing

The API use the following equations to determine the rated capacity of casing:

a. Collapse Rating

$$P_y = 2YP \left[\frac{\left(\frac{D}{t}\right) - 1}{\left(\frac{D}{t}\right)^2} \right] \quad \text{Yield Strength Collapse (Theoretical)}$$

$$P_p = YP \left[\frac{A}{\left(\frac{D}{t}\right)} - B \right] - C \quad \text{Plastic Collapse (Empirical)}$$

$$P_t = YP \left[\frac{F}{\left(\frac{D}{t}\right)} - G \right] \quad \text{Transition Collapse (Theoretical)}$$

$$P_c = \frac{2E}{1-\nu^2} / \left[\frac{D}{t} \left(\frac{D}{t} - 1\right)^2 \right] \quad \text{Plastic Collapse (Theoretical)}$$

where:

$$A = 2.8762 + 0.10679 \times 10^5 YP + 0.21301 \times 10^{-10} YP^2 - 0.53132 \times 10^{-16} YP^3$$

$$B = 0.026233 + 0.50609 \times 10^{-6} YP$$

$$C = -465.93 + 0.030867 YP - 0.10483 \times 10^{-7} YP^2 - 0.36989 \times 10^{-13} YP^3$$

$$F = \frac{\left[46.95 \times 10^6 \left(\frac{3B/A}{2+B/A} \right)^3 \right]}{\left[YP \left(\frac{3B/A}{2+B/A} \right) \left(1 - \frac{3B/A}{2+B/A} \right)^2 \right]}$$

$$G = FB/A$$

$$YP = \text{Yield Strength}$$

b. Internal yield pressure:

$$P = 0.875 \left(\frac{2YPt}{D} \right) \quad \text{Pipe Body}$$

c. Tensile Rating:

$$TR = Y_s A_s$$

d. Effects of Tension on Collapse Strength

$$Y_{pa} = \left\{ \sqrt{1 - 0.75 (\sigma_a / YP)^2} - 0.5 (\sigma_a / YP) \right\} YP$$

e. Triaxial Loading:

The triaxial Load is expressed in terms of the Von Mises Equivalent Stress. This is compared with the Minimum Yield Strength of the Casing.



CASING DESIGN EXAMPLE:

The table below is a data set from a real land well. As a drilling engineer you are required to calculate the burst and collapse loads that would be used to select an appropriate weight and grade of casing for the Surface, Intermediate and Production strings in this land well:

HOLE SIZE DEPTH (FT)	CASING SIZE (IN.)	Expected MIN./MAX. PORE PRESSURE GRAD. (PPG)	Expected LOT PRESSURE GRAD. (PPG)	MUDWEIGHT (PPG)	CEMENTING DATA				POTENTIAL HOLE PROBLEMS
					TOC	LEAD SLURRY (PPG)	TAIL SLURRY (PPG)	MIXWATER (PPG)	
Driven	30"	-	-	-	-	-	-	-	
26" 3000	20"	8.6	13.0 @ 3000'	9.0	seabed	13.5	15.88 500ft	8.5	
17 1/2" 6000	13 3/8"	8.6/9.5	16.0 @ 6000'	11.00	4300	13.5	15.88 500ft	8.5	Unconsolidated Caving/Sloughing Possible Lost Circ.
12 1/4" 10000	9 5/8"	9.5/11.0	16.5 @ 10000'	14.00	7500	13.5	15.88 500ft	8.5	Unstable Shales
8 1/2" 9500 - 12000	7" L	11.0/14.0		15.00	9500	15.88	15.88 500ft	8.5	Overpressured Shales

ASSUMPTIONS :

- Gas density above 10000ft : 0.1 psi/ft;
- Design Factor (Burst): 1.1
- Design Factor (Collapse): 1.0

PRODUCTION TEST DATA:

- Well test completion fluid density: 8.60 ppg;
- Test packer depth: 11000 ft TVD RKB;
- Test perforation depth: 11250 ft TVD RKB;
- Pressure at top of Perforations 14.0 ppg

Surface Casing (20" @ 3000 ft)

Burst Design - Drilling :

Internal Load: Assuming that an influx of gas has occurred and the well is full of gas to surface.

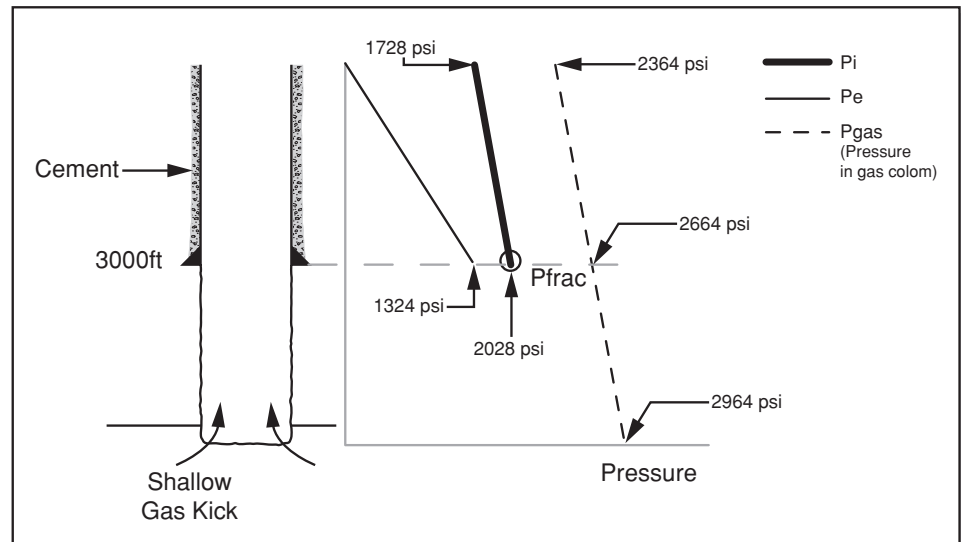

$$\begin{aligned} \text{Pore Pressure at bottom of } 17\frac{1}{2}\text{'' Hole} &= 9.5 \times 0.052 \times 6000 \\ &= 2964 \text{ psi} \end{aligned}$$

$$\begin{aligned} \text{Pressure at surface} &= \text{Pressure at Bottom of } 17\frac{1}{2}\text{'' hole} - \text{pressure due to colom of gas} \\ &= 2964 - (0.1 \times 6000) \\ &= 2364 \text{ psi} \end{aligned}$$

$$\begin{aligned} \text{Pressure at } 20\text{'' Casing Shoe} &= 2964 - (0.1 \times 3000) \\ &= 2664 \text{ psi} \end{aligned}$$

$$\begin{aligned} \text{LOT Pressure at } 20\text{'' casing shoe} &= 13 \times 0.052 \times 3000 \\ &= \mathbf{2028 \text{ psi}} \end{aligned}$$

The formation at the casing shoe will breakdown at 2028 psi and therefore it will breakdown if the pressure of 2664 psi is applied to it. The maximum pressure inside the surface casing at the shoe will therefore be 2028 psi.

$$\begin{aligned} \text{The maximum pressure at surface will be equal to the pressure at the shoe minus a colom of gas to surface:} \\ &= 2028 - (0.1 \times 3000) \\ &= \mathbf{1728 \text{ psi}} \end{aligned}$$

External Load: Assuming that the pore pressure is acting at the casing shoe and zero pressure at surface.



Pore pressure at the casing shoe $= 8.6 \times 0.052 \times 3000$
 $= \mathbf{1342 \text{ psi}}$

External pressure at surface $= \mathbf{0 \text{ psi}}$

SUMMARY OF BURST LOADS

DEPTH	EXTERNAL LOAD	INTERNAL LOAD	NET LOAD	DESIGN LOAD (LOAD X 1.1)
Surface	0	1728	1728	1901
Casing Shoe (3000 ft)	1342	2028	686	755

Collapse Design - Drilling

Internal Load: Assuming that the casing is totally evacuated due to losses of drilling fluid

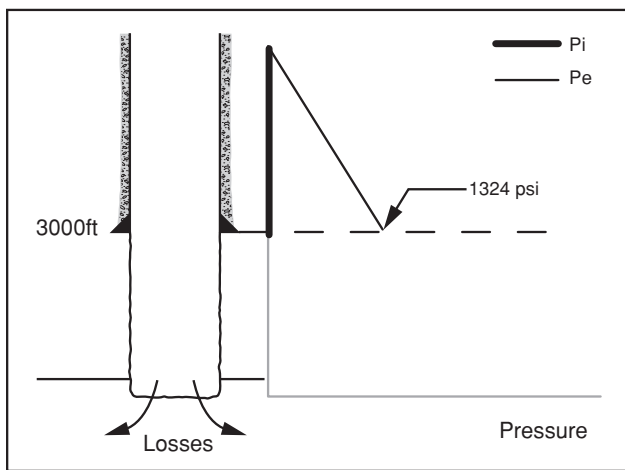

Internal Pressure at surface $= 0 \text{ psi}$

Internal Pressure at shoe $= 0 \text{ psi}$

External Load: Assuming that the pore pressure is acting at the casing shoe and zero pressure at surface.

Pore pressure at the casing shoe $= 8.6 \times 0.52 \times 3000$
 $= \mathbf{1342 \text{ psi}}$

External pressure at surface $= \mathbf{0 \text{ psi}}$

SUMMARY OF COLLAPSE LOADS

DEPTH	EXTERNAL LOAD	INTERNAL LOAD	NET LOAD	DESIGN LOAD (LOAD X 1.0)
Surface	0	0	0	0
Casing Shoe (3000 ft)	1342	0	1342	1342

Intermediate Casing (13 3/8" @ 6000 ft)

Burst Design - Drilling :

Internal Load: Assuming that an influx of gas has occurred and the well is full of gas to surface.

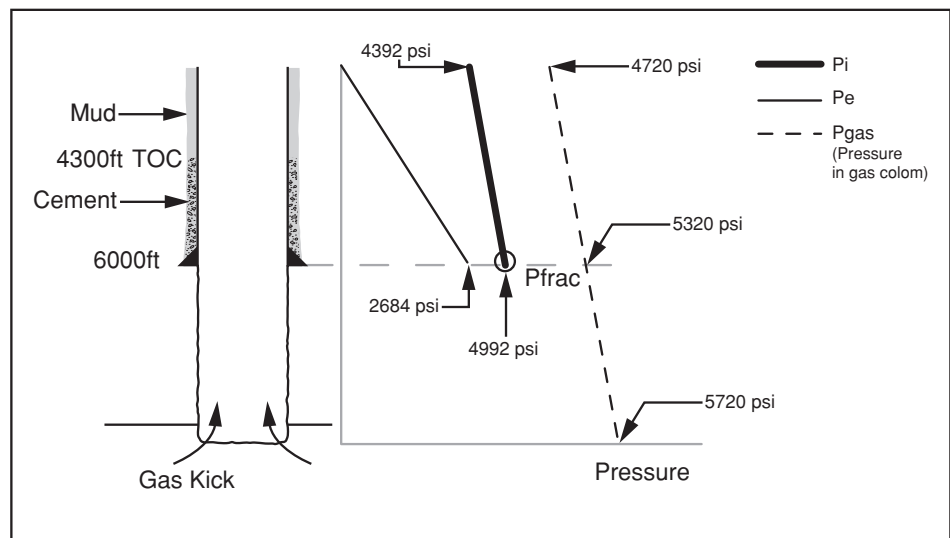

Pore Pressure at bottom of 12 1/4" Hole

$$= 11 \times 0.052 \times 10000$$

$$= 5720 \text{ psi}$$

Pressure at surface = Pressure at Bottom of 12 1/4" hole - pressure due to colom of gas

$$= 5720 - (0.1 \times 10000)$$

$$= 4720 \text{ psi}$$

Pressure at 13 3/8" Casing Shoe

$$= 5720 - (0.1 \times 4000)$$

$$= 5320 \text{ psi}$$

LOT Pressure at 13 3/8" casing shoe

$$= 16 \times 0.052 \times 6000$$

$$= \mathbf{4992 \text{ psi}}$$

The formation at the casing shoe will therefore breakdown when the well is closed in after the gas has flowed to surface. The maximum pressure inside the casing at the shoe will be 4992 psi.



The maximum pressure at surface will be equal to the pressure at the shoe minus a column of gas to surface:

$$= 4992 - (0.1 \times 6000)$$

$$= \mathbf{4392 \text{ psi}}$$

External Load: Assuming that the minimum pore pressure is acting at the casing shoe and zero pressure at surface.

Pore pressure at the casing shoe $= 8.6 \times 0.052 \times 6000$
 $= \mathbf{2684 \text{ psi}}$

External pressure at surface $= \mathbf{0 \text{ psi}}$

Summary of Burst Loads

DEPTH	External Load	Internal Load	Net Load	Design Load (Net Load x 1.1)
Surface	0	4392	4392	4831
Casing Shoe (6000ft)	2684	4992	2308	2539

Collapse Design - Drilling

Internal Load: Assuming that the casing is totally evacuated due to losses of drilling fluid

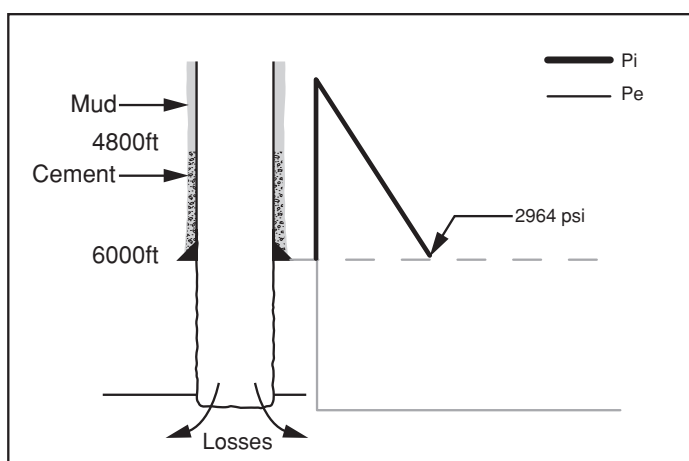

Internal Pressure at surface $= 0 \text{ psi}$

Internal Pressure at shoe $= 0 \text{ psi}$

External Load: Assuming that the maximum pore pressure is acting at the casing shoe and zero pressure at surface.

Pore pressure at the casing shoe $= 9.5 \times 0.052 \times 6000$
 $= \mathbf{2964 \text{ psi}}$

External pressure at surface = 0 psi

Summary of Collapse Loads

DEPTH	External Load	Internal Load	Net Load	Design Load (Net Load x 1.0)
Surface	0	0	0	0
Casing Shoe (6000ft)	2964	0	2964	2964

Production Casing (9 5/8" @ 10000 ft)

Burst Design - Production :

Internal Load: Assuming that a leak occurs in the tubing at surface and that the closed in tubing head pressure (CITHP) is acting on the inside of the top of the casing. This pressure will then act on the colom of packer fluid. The 9 5/8" casing is only exposed to these pressure down to the Top of Liner (TOL). The 7" liner protects the remainder of the casing.

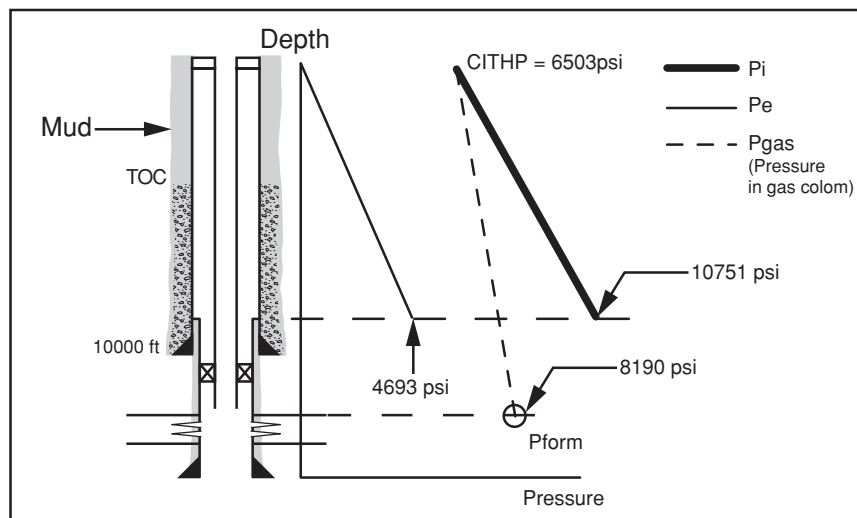

$$\begin{aligned} \text{Max. Pore Pressure at the top of the production zone} \\ &= 14 \times 0.052 \times 11250 \\ &= 8190 \text{ psi} \end{aligned}$$

$$\begin{aligned} \text{CITHP (at surface) - Pressure at Top of Perfs - pressure due to colom of gas (0.15} \\ \text{psi/ft)} \\ &= 8190 - 0.15 \times 11250 \\ &= \mathbf{6503 \text{ psi}} \end{aligned}$$

$$\begin{aligned} \text{Pressure at Top of Liner} &= \text{CITHP plus hydrostatic colom of packer fluid} \\ &= 6503 + (8.6 \times 0.052 \times 9500) \\ &= \mathbf{10751 \text{ psi}} \end{aligned}$$



External Load: Assuming that the minimum pore pressure is acting at the liner depth and zero pressure at surface.

Pore pressure at the Top of Liner $= 9.5 \times 0.052 \times 9500$
 $= \mathbf{4693 \text{ psi}}$

External pressure at surface $= \mathbf{0 \text{ psi}}$

Summary of Burst Loads

DEPTH	External Load	Internal Load	Net Load	Design Load (Net Load x 1.1)
Surface	0	6503	6503	7153
TOL (9500ft)	4693	10751	6058	6664

Collapse Design - Drilling

Internal Load: Assuming that the casing is totally evacuated due to gaslifting operations

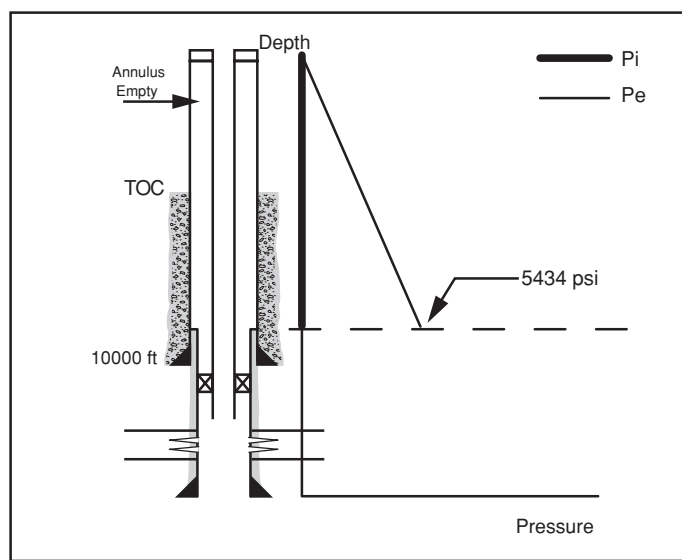

Internal Pressure at surface $= 0 \text{ psi}$

Internal Pressure at Top of Liner (TOL) $= 0 \text{ psi}$

External Load: Assuming that the maximum pore pressure is acting on the outside

of the casing at the TOL

Pore pressure at the TOL $= 11 \times 0.52 \times 9500$
 $= 5434 \text{ psi}$

SUMMARY OF COLLAPSE LOADS

DEPTH	EXTERNAL LOAD	INTERNAL LOAD	NET LOAD	DESIGN LOAD (LOAD X 1.0)
Surface	0	0	0	0
TOL (9500 ft)	5434	0	5434	5434

Cementing 8

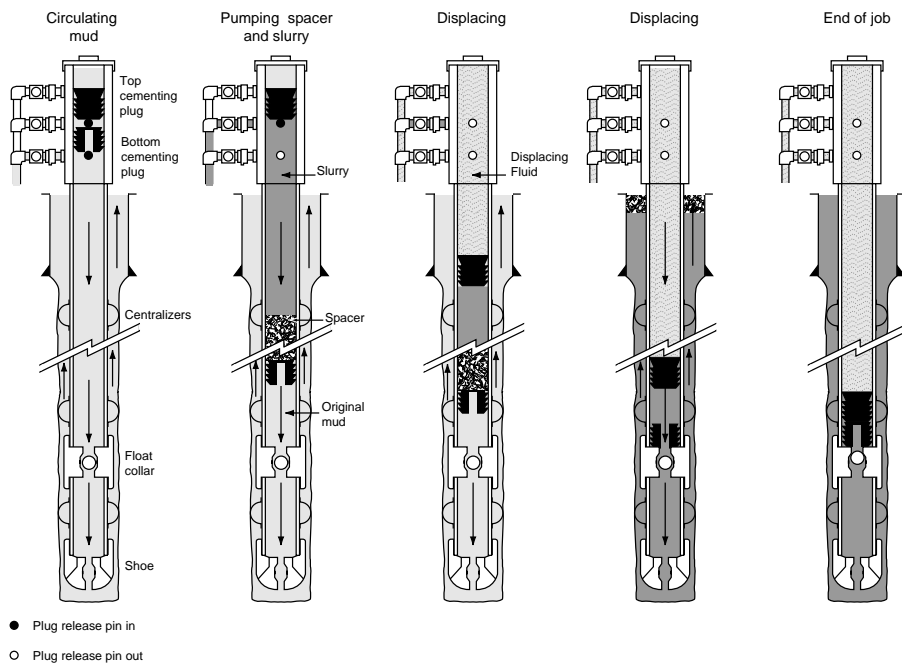

CONTENTS

1. OILWELL CEMENTS

- 1.1 Functions of oilwell cement
- 1.2 Classification of cement powders
- 1.3 Mixwater Requirements

2. PROPERTIES OF CEMENT

3. CEMENT ADDITIVES

4. PRIMARY CEMENTING

- 4.1 Downhole cementing equipment
- 4.2 Surface cementing equipment
- 4.3 Single Stage Cementing Operation
- 4.4 Multi - Stage cementing Operation
- 4.5 Inner string cementing
- 4.6 Liner cementing
- 4.7 Recommendations for a good cement job

5. SQUEEZE CEMENTING

- 5.1 High Pressure Squeeze
- 5.2 Low pressure squeeze
- 5.3 Equipment used for squeeze cementing
- 5.4 Testing the squeeze job

6. CEMENT PLUGS

7. EVALUATION OF CEMENT JOBS





LEARNING OBJECTIVES :

Having worked through this chapter the student will be able to:

General

- Describe the principal functions of cement.

Cement Slurries

- List and describe the major properties of a cement slurry.
- Describe the additives used in cement slurries and the way in which they affect the properties of the slurry.

Cementing Operations

- Calculate the volume of : slurry, cement, mixwater, displacing fluid required for a single stage and two-stage cementing operation.
- Calculate the bottomhole pressures generated during the above cementing operations.
- Describe the surface and downhole equipment used in a single, two-stage and liner cementation operation.
- Prepare a program for a single and two stage cementing operation and describe the ways in which a good cement bond can be achieved.

Cement Plugs

- Describe the reasons for setting cement plugs.
- Describe the principal methods for placing a cement plug in casing or open hole.
- Calculate the displacement volumes for an underbalanced cement plug.

Evaluation of Cementing Operations

- Describe the principles involved and the tools and techniques used to evaluate the quality of a cementing operation.
- Discuss the limitations of the above techniques.

1. INTRODUCTION

Cement is used primarily as an impermeable seal material in oil and gas well drilling. It is most widely used as a seal between casing and the borehole, bonding the casing to the formation and providing a barrier to the flow of fluids from, or into, the formations behind the casing and from, and into, the subsequent hole section (Figure 1). Cement is also used for remedial or repair work on producing wells. It is used for instance to seal off perforated casing when a producing zone starts to produce large amounts of water and/or to repair casing leaks. This chapter will present: the reasons for using cement in oil and gas well drilling; the design of the cement slurry; and the operations involved in the placement of the cement slurry. The methods used to determine if the cementing operation has been successful will also be discussed.

1.1 Functions of oilwell cement

There are many reasons for using cement in oil and gaswell operations. As stated above, cement is most widely used as a seal between casing and the borehole, bonding the casing to the formation and providing a barrier to the flow of fluids from, or into, the formations behind the casing and from, and into, the subsequent hole section (Figure 1). However, when placed between the casing and borehole the cement may be required to perform some other tasks. The most important functions of a cement sheath between the casing and borehole are:

- To prevent the movement of fluids from one formation to another or from the formations to surface through the annulus between the casing and borehole.
- To support the casing string (specifically surface casing)
- To protect the casing from corrosive fluids in the formations.

However, the prevention of fluid migration is by far the most important function of the cement sheath between the casing and borehole. Cement is only required to support the casing in the case of the surface casing where the axial loads on the casing, due to the weight of the wellhead and BOP connected to the top of the casing string, are extremely high. The cement sheath in this case prevents the casing from buckling.

The techniques used to place the cement in the annular space will be discussed in detail later but basically the method of doing this is to pump cement down the inside of the casing and through the casing shoe into the annulus (Figure 2). This operation is known as a **primary cement job**. A successful primary cement job is essential to allow further drilling and production operations to proceed.

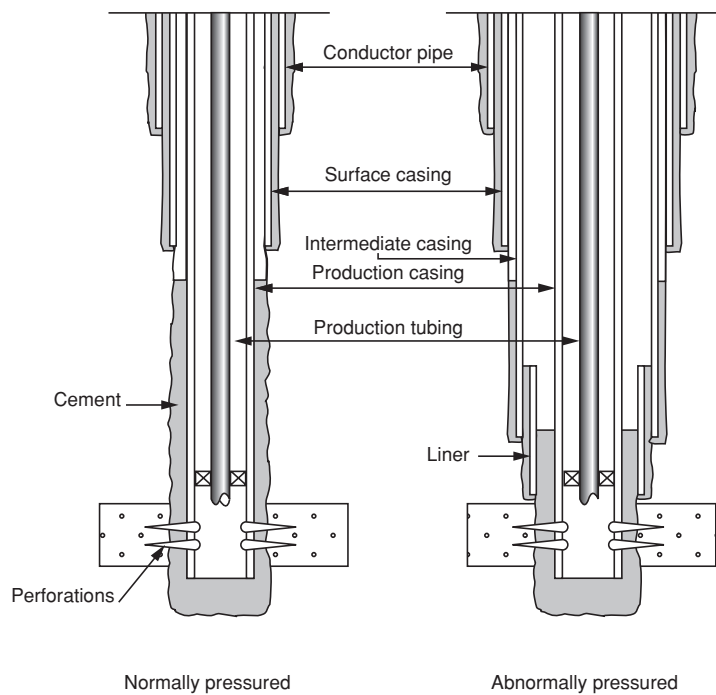

Figure 1 Functions of Primary Cementing

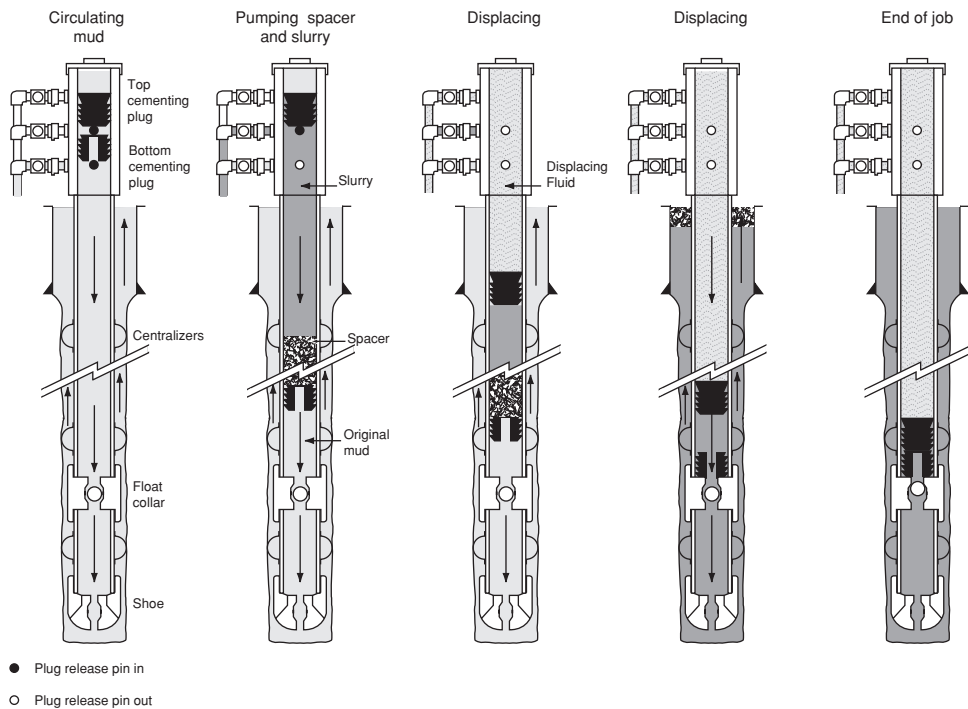
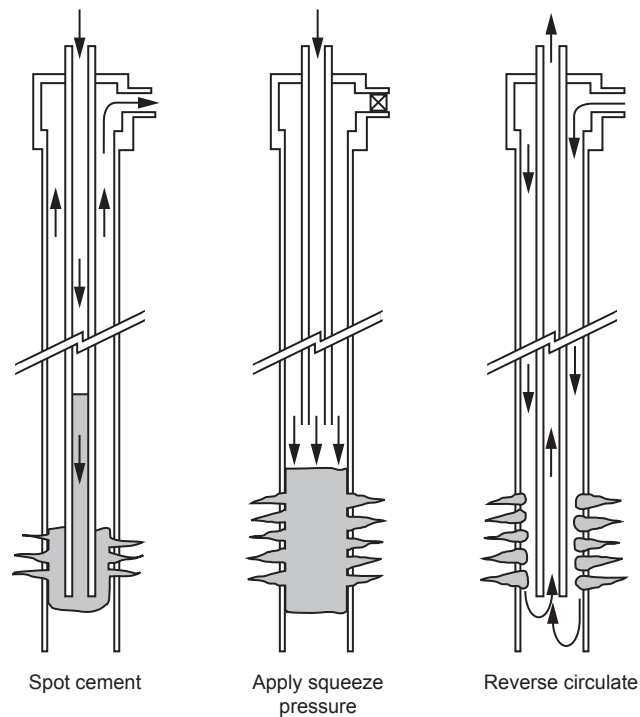

Figure 2 Primary Cementing Operations



Schematic of Bradenhead squeeze technique normally used on low pressure formations. Cement is circulated into place down drill pipe (left), then the wellhead, or BOP, is closed (centre) and squeeze pressure is applied. Reverse circulating through perforations (right) removes excess cement, or the plug can be drilled out.

Figure 3 Secondary or Squeeze Cementing Operation

Another type of cement job that is performed in oil and gas well operations is called a **secondary or squeeze cement job**. This type of cement job may have to be done at a later stage in the life of the well. A secondary cement job may be performed for many reasons, but is usually carried out on wells which have been producing for some time. They are generally part of remedial work on the well (e.g. sealing off water producing zones or repairing casing leaks). These cement jobs are often called squeeze cement jobs because they involve cement being forced through holes or perforations in the casing into the annulus and/or the formation (Figure 3).

The specific properties of the cement slurry which is used in the primary and secondary cementing operations discussed above will depend on the particular reason for using the cement (e.g. to plug off the entire wellbore or simply to plug off perforations) and the conditions under which it will be used (e.g. the pressure and temperature at the bottom of the well).

The cement slurry which is used in the above operations is made up from: cement powder; water; and chemical additives. There are many different grades of cement powder manufactured and each has particular attributes which make it suitable for a particular type of operation. These grades of cement powder will be discussed below. The water used may be fresh or salt water. The chemical additives (Figure

4) which are mixed into the cement slurry alter the properties of both the cement slurry and the hardened cement and will be discussed at length in Section 3 below.

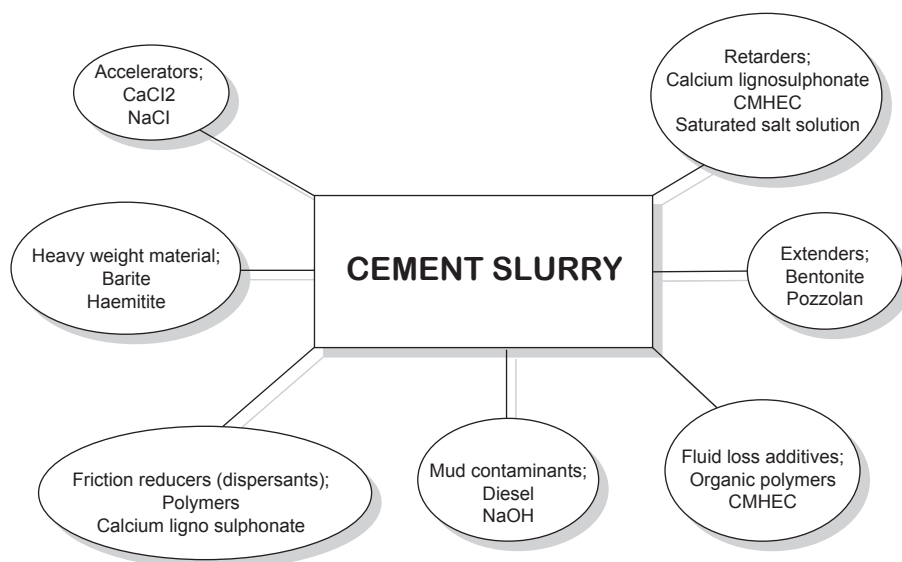

Figure 4 Major cement additives

API Class	Compounds*					Fineness SQq. cm/Gram
	C3S	C2S	C3A	C4AF	CaSO4	
A	53	24	8	8	3.5	1600-1900
B	44	32	5	12	2.9	1500-1900
C	58	16	8	8	4.1	2000-2400
D&E	50	26	5	13	3	1200-1500
G	52	27	3	12	3.2	1400-1600
H	52	25	5	12	3.3	1400-1600

*Plus free lime, alkali, (Na, K, Mg)

Table 1 Composition of API Cements

Each cement job must be carefully planned to ensure that the correct cement and additives are being used, and that a suitable placement technique is being employed for that particular application. In planning the cement job the engineer must ensure that:

- The cement can be placed correctly using the equipment available
- The cement will achieve adequate compressive strength soon after it is placed
- The cement will thereafter isolate zones and support the casing throughout the life of the well

To assist the engineer in designing the cement slurry, the cement slurry is tested in the laboratory under the conditions to which it will be exposed in the wellbore. These tests are known as *pilot tests* and are carried out before the job goes ahead. These tests must simulate downhole conditions as closely as possible. They will

help to assess the effect of different amounts of additives on the properties of the cement (e.g. thickening time, compressive strength development etc).

API Class	Mixwater Gals/Sk.	Slurry Weight Lbs/Gal.
A	5.2	15.6
B	5.2	15.6
C	6.3	14.8
D	4.3	16.4
E	4.3	16.4
F	4.3	16.2
G	5.0	15.8
H	4.3	16.4

Table 2 API Mixwater requirements for API cements

1.2 Classification of cement powders

There are several classes of cement powder which are approved for oilwell drilling applications, by the American Petroleum Institute - API. Each of these cement powders have different properties when mixed with water. The difference in properties produced by the cement powders is caused by the differences in the distribution of the four basic compounds which are used to make cement powder; C_3S , C_2S , C_3A , C_4AF (Table 1).

Classes A and B - These cements are generally cheaper than other classes of cement and can only be used at shallow depths ,where there are no special requirements. Class B has a higher resistance to sulphate than Class A.

Class C - This cement has a high C_3S content and therefore becomes hard relatively quickly.

Classes D,E and F - These are known as retarded cements since they take a much longer time to set hard than the other classes of cement powder. This retardation is due to a coarser grind. These cement powders are however more expensive than the other classes of cement and their increased cost must be justified by their ability to work satisfactorily in deep wells at higher temperatures and pressures.

Class G and H - These are general purpose cement powders which are compatible with most additives and can be used over a wide range of temperature and pressure. Class G is the most common type of cement and is used in most areas . Class H has a coarser grind than Class G and gives better retarding properties in deeper wells.

There are other, non-API, terms used to classify cement. These include the following:

- **Pozmix cement** - This is formed by mixing Portland cement with pozzolan (ground volcanic ash) and 2% bentonite. This is a very lightweight but durable cement. Pozmix cement is less expensive than most other types of cement and due to its light weight is often used for shallow well casing cementation operations.



	Portland	API Class G	API ClassH
Water, gal./sk.	5.19	4.97	4.29
Slurry Wt. lb./gal.	15.9	15.8	16.5
Slurry Vol. cuft./sk.	1.8	1.14	1.05
Temp. (deg. F)	Pressure (psi)	Typical comp. strength (psi) @ 12hrs	
60	0	615	440
80	0	1470	1185
95	800	2085	2540
110	1600	2925	2915
140	3000	5050	4200
170	3000	5920	4380
200	3000	-	5110
		Typical comp. strength (psi) @ 24hrs	
60	0	2870	-
80	0	4130	-
95	800	4130	-
110	1600	5840	-
140	3000	6550	7125
170	3000	6210	5865
200	3000	-	7360

Table 3 Compressive strength of cements

- **Gypsum Cement** - This type of cement is formed by mixing Portland cement with gypsum. These cements develop a high early strength and can be used for remedial work. They expand on setting and deteriorate in the presence of water and are therefore useful for sealing off lost circulation zones.

- **Diesel oil cement** - This is a mixture of one of the basic cement classes (A, B, G, H), diesel oil or kerosene and a surfactant. These cements have unlimited setting times and will only set in the presence of water. Consequently they are often used to seal off water producing zones, where they absorb and set to form a dense hard cement.

1.3 Mixwater Requirements

The water which is used to make up the cement slurry is known as the *mixwater*. The amount of mixwater used to make up the cement slurry is shown in Table 2. These amounts are based on :

- The need to have a slurry that is easily pumped.
- The need to hydrate all of the cement powder so that a high quality hardened cement is produced.
- The need to ensure that all of the free water is used to hydrate the cement powder and that no free water is present in the hardened cement.

The amount of mixwater that is used to make up the cement slurry is carefully controlled. If too much mixwater is used the cement will not set into a strong, impermeable cement barrier. If not enough mixwater is used :

- The slurry density and viscosity will increase.
- The pumpability will decrease
- Less volume of slurry will be obtained from each sack of cement

The quantities of mixwater quoted in Table 2 are average values for the different classes of cement. Sometimes the amount of mixwater used will be changed to meet the specific temperature and pressure conditions which will be experienced during the cement job.

2. PROPERTIES OF CEMENT

The properties of a specific cement slurry will depend on the particular reason for using the cement, as discussed above. However, there are fundamental properties which must be considered when designing any cement slurry.

(a) Compressive strength

The casing shoe should not be drilled out until the cement sheath has reached a compressive strength of about 500 psi. This is generally considered to be enough to support a casing string and to allow drilling to proceed without the hardened cement sheath, disintegrating, due to vibration. If the operation is delayed whilst waiting on the cement to set and develop this compressive strength the drilling rig is said to be “**waiting on cement**” (WOC). The development of compressive strength is a function of several variables, such as: temperature; pressure; amount of mixwater added; and elapsed time since mixing.

The setting time of a cement slurry can be controlled with chemical additives, known as **accelerators**. Table 3 shows the compressive strengths for different cements under varying conditions.

(b) Thickening time (pumpability)

The thickening time of a cement slurry is the time during which the cement slurry can be pumped and displaced into the annulus (i.e. the slurry is pumpable during this time). The slurry should have sufficient thickening time to allow it to be:

- Mixed
- Pumped into the casing
- Displaced by drilling fluid until it is in the required place

Generally 2 - 3 hours thickening time is enough to allow the above operations to be completed. This also allows enough time for any delays and interruptions in the cementing operation. The thickening time that is required for a particular operation will be carefully selected so that the following operational issues are satisfied:

- The cement slurry does not set whilst it is being pumped
- The cement slurry is not sitting in position as a slurry for long periods, potentially being contaminated by the formation fluids or other contaminants



- The rig is not waiting on cement for long periods.

Wellbore conditions have a significant effect on thickening time. An increase in temperature, pressure or fluid loss will each reduce the thickening time and these conditions will be simulated when the cement slurry is being formulated and tested in the laboratory before the operation is performed.

(c) Slurry density

The standard slurry densities shown in Table 2 may have to be altered to meet specific operational requirements (e.g. a low strength formation may not be able to support the hydrostatic pressure of a cement slurry whose density is around 15 ppg). The density can be altered by changing the amount of mixwater or using additives to the cement slurry. Most slurry densities vary between 11 - 18.5 ppg. It should be noted that these densities are relatively high when the normal formation pore pressure gradient is generally considered to be equivalent to 8.9 ppg. It is generally the case that cement slurries generally have a much higher density than the drilling fluids which are being used to drill the well. The high slurry densities are however unavoidable if a hardened cement with a high compressive strength is to be achieved.

(d) Water loss

The slurry setting process is the result of the cement powder being hydrated by the mixwater. If water is lost from the cement slurry before it reaches its intended position in the annulus its pumpability will decrease and water sensitive formations may be adversely affected. The amount of water loss that can be tolerated depends on the type of cement job and the cement slurry formulation.

Squeeze cementing requires a low water loss since the cement must be squeezed before the filter cake builds up and blocks the perforations. Primary cementing is not so critically dependent on fluid loss. The amount of fluid loss from a particular slurry should be determined from laboratory tests. Under standard laboratory conditions (1000 psi filter pressure, with a 325 mesh filter) a slurry for a squeeze job should give a fluid loss of 50 - 200 cc. For a primary cement job 250 - 400 cc is adequate.

(e) Corrosion resistance

Formation water contains certain corrosive elements which may cause deterioration of the cement sheath. Two compounds which are commonly found in formation waters are sodium sulphate and magnesium sulphate. These will react with lime and C_3S to form large crystals of calcium sulphoaluminate. These crystals expand and cause cracks to develop in the cement structure. Lowering the C_3A content of the cement increases the sulphate resistance. For high sulphate resistant cement the C_3A content should be 0 - 3%

(f) Permeability

After the cement has hardened the permeability is very low (<0.1 millidarcy). This is much lower than most producing formations. However if the cement is disturbed during setting (e.g. by gas intrusion) higher permeability channels (5 - 10 darcies) may be created during the placement operation.

SLURRY COMPOSITION							
Cement Class	Gel %	Mixwater %	Mixwater gal/sk.	cu. ft/sk	Slurry Density		Slurry Volume cu. ft/sk
					ppg	pcf	
G	0	44.0	4.96	0.663	15.9	118.70	1.14
G	4	65.2	7.35	0.982	14.3	107.00	1.49
G	8	88.4	9.74	1.302	13.3	99.77	1.83
G	12	107.2	12.10	1.621	12.7	94.83	2.18
G	16	128.8	14.50	1.940	12.2	91.24	2.52

THICKENING TIME						
Cement Class	Gel %	Casing Schedules, Hrs; mins.				
		2000 ft	4000ft	6000ft	8000ft	10000ft
		91 deg F	103 deg F	113 deg F	126 deg F	144 deg F
G	0	4:30	2:50	2:24	1:50	1:20
G	4	4:10	2:18	1:51	1:27	0:57
G	8	5:00	2:43	2:06	1:38	1:04

COMPRESSIVE STRENGTH, psi							
Cement Class	Gel %	Time hrs.	80 deg F	100 deg F	120 deg F	140 deg F	160 deg F
			G	0	24	1800	3050
G	4	24	860	1250	1830	1950	2210
G	8	24	410	670	890	1090	1340

Table 4 Cements with bentonite

3. CEMENT ADDITIVES

Most cement slurries will contain some additives, to modify the properties of the slurry and optimise the cement job. Most additives are known by the trade-names used by the cement service companies. Cement additives can be used to:

- Vary the slurry density
- Change the compressive strength
- Accelerate or retard the setting time
- Control filtration and fluid loss
- Reduce slurry viscosity

Additives may be delivered to the rig in granular or liquid form and may be blended with the cement powder or added to the mixwater before the slurry is mixed. The amount of additive used is usually given in terms of a percentage by weight of the cement powder (based on each sack of cement weighing 94 lb). Several additives will affect more than one property and so care must be taken as to how they are used (Figure 4).



It should be remembered that the slurry is mixed up and tested in the laboratory before the actual cement job.

(a) Accelerators

Accelerators are added to the cement slurry to shorten the time taken for the cement to set. These are used when the setting time for the cement would be much longer than that required to mix and place the slurry, and the drilling rig would incur WOC time. Accelerators are especially important in shallow wells where temperatures are low and therefore the slurry may take a long time to set. In deeper wells the higher temperatures promote the setting process, and accelerators may not be necessary.

The most common types of accelerator are:

- Calcium chloride (CaCl_2) 1.5 - 2.0%
- Sodium chloride (NaCl) 2.0 - 2.5%
- Seawater

It should be noted that at higher concentrations these additives will act as retarders.

(b) Retarders

In deep wells the higher temperatures will reduce the cement slurry's thickening time. Retarders are used to prolong the thickening time and avoid the risk of the cement setting in the casing prematurely. The bottom hole temperature is the critical factor which influences slurry setting times and therefore for determining the need for retarders. Above a static temperature of 260 - 275 degrees F the effect of retarders should be measured in pilot tests.

The most common types of retarders are:

- Calcium lignosulphanate (sometimes with organic acids) 0.1 - 1.5%
- Saturated Salt Solutions

(c) Lightweight additives (Extenders)

Extenders are used to reduce slurry density for jobs where the hydrostatic head of the cement slurry may exceed the fracture strength of certain formations. In reducing the slurry density the ultimate compressive strength is also reduced and the thickening time increased. The use of these additives allows more mixwater to be added, and hence increases the amount of slurry which is produced by each sack of cement powder (**the yield of the slurry**). Such additives are therefore sometimes called **extenders**.

The most common types of lightweight additives are:

- Bentonite (2 - 16%) - This is by far the most common type of additive used to lower slurry density. The bentonite material absorbs water, and therefore allows more mixwater to be added. Bentonite will also however reduce compressive strength and sulphate resistance. The increased yield due to the bentonite added is shown in Table 4.

- Pozzolan - This may be used in a 50/50 mix with the Portland cement. The result is a slight decrease in compressive strength, and increased sulphate resistance.
- Diatomaceous earth (10 - 40%) - The large surface area of diatomaceous earth allows more water absorption, and produces low density slurries (down to 11 ppg).

(d) Heavyweight additives

Heavyweight additives are used when cementing through overpressured zones. The most common types of additive are:

- Barite (barium sulphate) - this can be used to attain slurry densities of up to 18ppg. It also causes a reduction in strength and pumpability.
- Hematite (Fe_2O_3) - The high specific gravity of hematite can be used to raise slurry densities to 22 ppg. Hematite significantly reduces the pumpability of slurries and therefore friction reducing additives may be required when using hematite.
- Sand - graded sand (40 - 60 mesh) can give a 2 ppg increase in slurry density.

(e) Fluid loss additives

Fluid loss additives are used to prevent dehydration of the cement slurry and premature setting. The most common additives are:

- Organic polymers (cellulose) 0.5 - 1.5%
- Carboxymethyl hydroxyethyl cellulose (CMHEC) 0.3 - 1.0%
(CMHEC will also act as a retarder)

(f) Friction reducing additives (Dispersants)

Dispersants are added to improve the flow properties of the slurry. In particular they will lower the viscosity of the slurry so that turbulence will occur at a lower circulating pressure, thereby reducing the risk of breaking down formations. The most commonly used are:

- Polymers 0.3 - 0.5 lb/sx of cement
- Salt 1 - 16 lb/sx
- Calcium lignosulphanate 0.5 - 1.5 lb/sxg)

(g) Mud contaminates

As well as the compounds deliberately added to the slurry on surface, to improve the slurry properties, the cement slurry will also come into contact with, and be contaminated by, drilling mud when it is pumped downhole. The chemicals in the mud may react with the cement to give undesirable side effects. Some of these are listed below:

<u>Mud additive</u>	<u>Effect on cement</u>
barite	increases density and reduces compressive strength
caustic	acts as an accelerator



calcium compounds	decrease density
diesel oil	decrease density
thinners	act as retarders

The mixture of mud and cement causes a sharp increase in viscosity. The major effect of a highly viscous fluid in the annulus is that it forms channels which are not easily displaced. These channels prevent a good cement bond all round the casing.

To prevent mud contamination of the cement a spacer fluid is pumped ahead of the cement slurry.

4. PRIMARY CEMENTING

The objective of a primary cement job is to place the cement slurry in the annulus behind the casing. In most cases this can be done in a single operation, by pumping cement down the casing, through the casing shoe and up into the annulus. However, in longer casing strings and in particular where the formations are weak and may not be able to support the hydrostatic pressure generated by a very long column of cement slurry, the cement job may be carried out in two stages. The first stage is completed in the manner described above, with the exception that the cement slurry does not fill the entire annulus, but reaches only a pre-determined height above the shoe. The second stage is carried out by including a special tool in the casing string which can be opened, allowing cement to be pumped from the casing and into the annulus. This tool is called a multi stage cementing tool and is placed in the casing string at the point at which the bottom of the second stage is required. When the second stage slurry is ready to be pumped the multi stage tool is opened and the second stage slurry is pumped down the casing, through the stage cementing tool and into the annulus, as in the first stage. When the required amount of slurry has been pumped, the multi stage tool is closed. This is known as a **two stage cementing operation** and will be discussed in more detail later.

The height of the cement sheath, above the casing shoe, in the annulus depends on the particular objectives of the cementing operations. In the case of conductor and surface casing the whole annulus is generally cemented so that the casing is prevented from buckling under the very high axial loads produced by the weight of the wellhead and BOP. In the case of the intermediate and production casing the top of the cement sheath (**Top of Cement - TOC**) is generally selected to be approximately 300-500 ft. above any formation that could cause problems in the annulus of the casing string being cemented. For instance, formations that contain gas which could migrate to surface in the annulus would be covered by the cement. Liners are generally cemented over their entire length, all the way from the liner shoe to the liner hanger.

4.1 Downhole cementing equipment

In order to carry out a conventional primary cement job some special equipment must be included in the casing string as it is run.

- Guide shoe - A guide (Figure 5) shoe is run on the bottom of the first joint of casing. It has a rounded nose to guide the casing past any ledges or other irregularities in the hole .

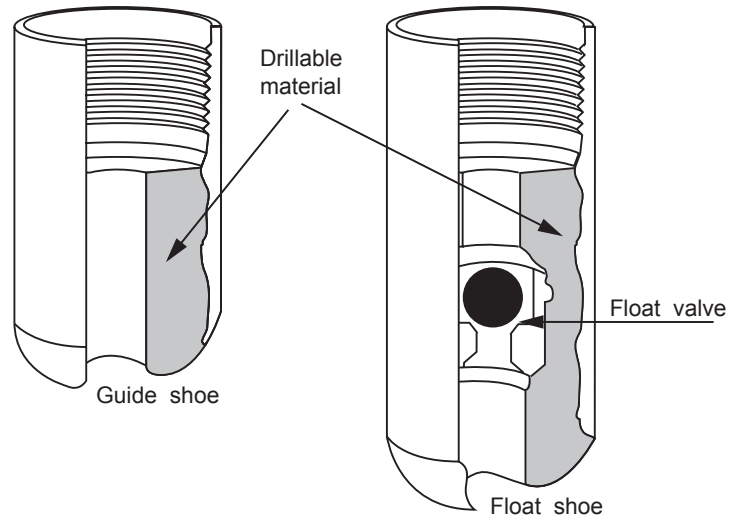

Figure 5 Guide shoe and float shoe

- Float collar - A float collar (Figure 6) is positioned 1 or 2 joints above the guide shoe. It acts as a seat for the cement plugs used in the pumping and displacement of the cement slurry. This means that at the end of the cement job there will be some cement left in the casing between the float collar and the guide shoe which must be drilled out.

The float collar also contains a non-return valve so that the cement slurry cannot flow back up the casing. This is necessary because the cement slurry in the annulus generally has a higher density than the displacing fluid in the casing, therefore a U-tube effect is created when the cement is in position and the pumps are stopped. Sometimes the guide shoe also has a non-return valve as an extra precaution. It is essential that the non-return valves are effective in holding back the cement slurry.

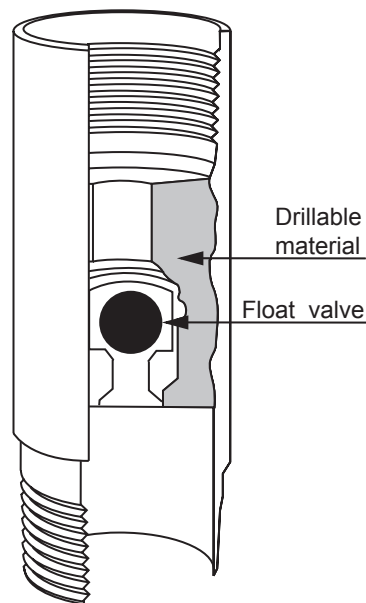

Figure 6 Float collar

The use of a non-return valve means that as the casing is being run into the borehole the fluid in the hole cannot enter the casing from below. This creates a buoyancy effect which can be reduced by filling up the casing from the surface at regular intervals while the casing is being run (every 5 - 20 joints). This filling up process increases the running in time and can be avoided by the use of automatic or differential fill up devices fitted to the float collar or shoe. These devices allow a controlled amount of fluid to enter the casing at the bottom of the string. The ports through which the fluid enters are blocked off before the cement job begins. The use of a differential fill-up device also reduces the effect of surge pressures on the formation .

- Centralisers - these are hinged metal ribs which are installed on the casing string as it is run (Figure 7). Their function is to keep the casing away from the borehole so that there is some annular clearance around the entire circumference of the casing

The proper use of centralisers will help to:

- Improve displacement efficiency (i.e. place cement all the way around the casing)
- Prevent differential sticking
- Keep casing out of keyseats

Centralisers are particularly required in deviated wells where the casing tends to lie on the low side of the hole. On the high side there will be little resistance to flow, and so cement placement will tend to flow up the high side annular space. Mud channels will tend to form on the low side of the hole, preventing a good cement job. Each centraliser is hinged so that it can be easily clamped onto the outside of the casing and secured by a retaining pin. The centraliser is prevented from moving up and down the casing by positioning the centraliser across a casing coupling or a collar known as a *stop collar*. The spacing of centralisers will vary depending on the requirements of each cement job. In critical zones, and in highly deviated parts of the well, they are closely spaced, while on other parts of the casing string they may not be necessary at all. A typical programme might be:

- 1 centraliser immediately above the shoe
- 1 every joint on the bottom 3 joints
- 1 every joint through the production zone
- 1 every 3 joints elsewhere

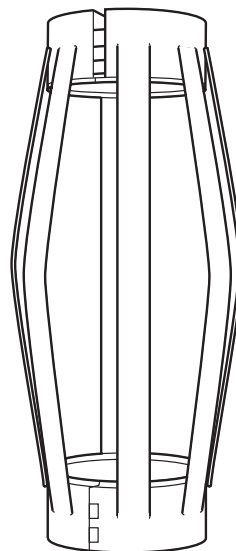

Figure 7 Casing Centraliser

- Wipers/scratchers - these are devices run on the outside of the casing to remove mud cake and break up gelled mud. They are sometimes used through the production zone.

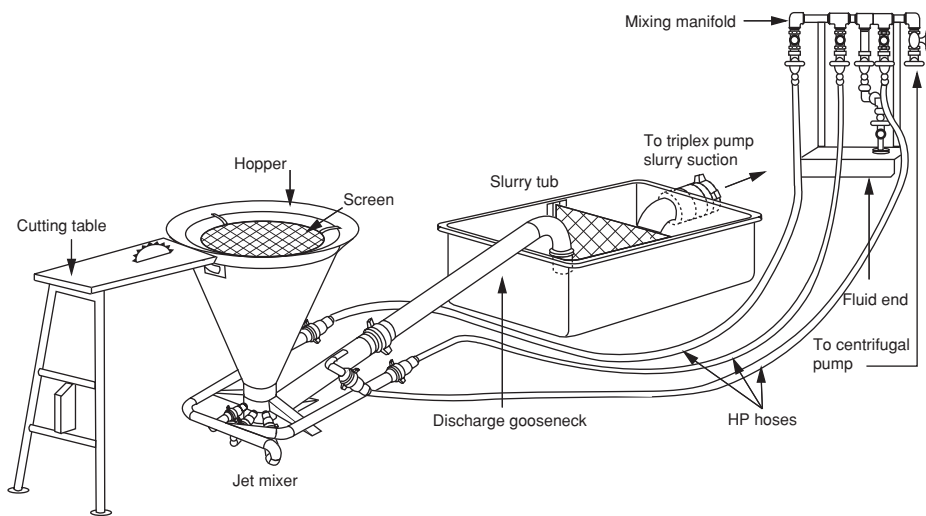

Figure 8 Cement unit showing jet mixer

4.2 Surface cementing equipment

Mixing and pumping facilities:

On most rigs cement powder and additives are handled in bulk, which makes blending and mixing much easier. For large volume cement jobs several bulk storage bins may be required on the rig. On offshore rigs the cement is transferred pneumatically from supply boats to the storage bins.

For any cement job there must be sufficient water available to mix the slurry at the desired water/cement ratio when required. The mix water must also be free of all contaminants.

The water is added to the cement in a *jet mixer* (Figure 8). The mixer consists of a funnel shaped hopper, a mixing bowl, a water supply line and an outlet for the slurry. As the mixwater is pumped across the lower end of the hopper a venturi effect is created and cement powder is drawn down into the flow of mixwater and a slurry is created. The slurry flows into a slurry tub where its density is measured. The density of the slurry should be regularly checked during the cement job since this is the primary means by which the quality of the slurry is determined. If the density of the slurry is correct then the correct amount of mixwater has been mixed with the cement powder. Samples can be taken directly from the mixer and weighed in a standard mud balance or automatic devices (densometers) can also be used.

Various types of cement pumping units are available. For land based jobs they can be mounted on a truck, while skid mounted units are used offshore. The unit normally has twin pumps (triplex, positive displacement) which may be diesel powered or driven by electric motors. These units can operate at high pressures (up to 20,000 psi) but are generally limited to low pumping rates. Most units are capable of mixing and displacing 50 - 70 cubic feet of slurry per minute. In order to minimise contamination by the mud in the annulus a preflush or spacer fluid is pumped ahead of the cement slurry. The actual composition of the spacer depends

on the type of mud being used. For water based muds the spacer fluid is often just water, but specially designed fluids are available. The volume of spacer is based on the need to provide sufficient separation of mud and cement in the annulus (20 - 50 bbls of spacer is common).

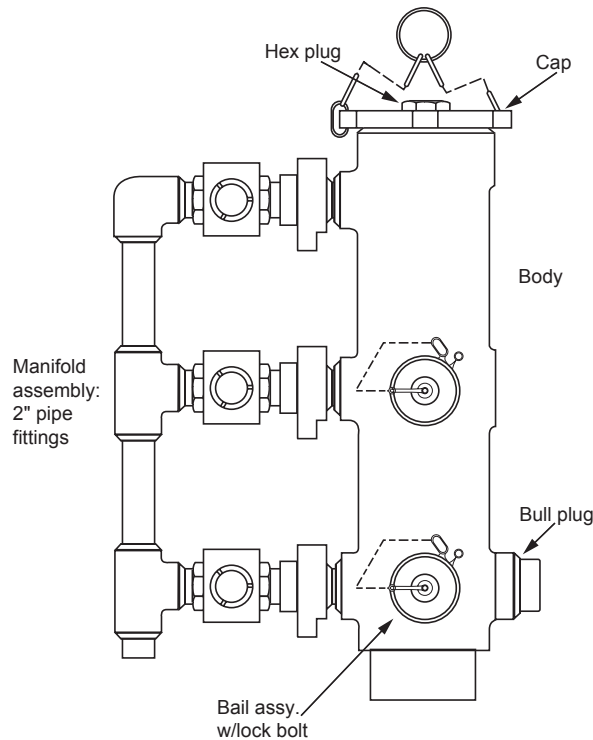

Figure 9 Cement Head

Cementing heads:

The cement head provides the connection between the discharge line from the cement unit and the top of the casing (Figure 9). This piece of equipment is designed to hold the cement plugs used in the conventional primary cement job. The cement head makes it possible to release the bottom plug, mix and pump down the cement slurry, release the top plug and displace the cement without making or breaking the connection to the top of the casing. For ease of operation the cement head should be installed as close to rig floor level as possible. The cement jobs will be unsuccessful if the cement plugs are installed in the correct sequence or are not released from the cementing head.

Mud is normally used to displace the cement slurry. The cement pumps or the rig pumps may be used for the displacement. It is recommended that the cement slurry is displaced at as high a rate as possible. High rate displacement will aid efficient mud displacement. It is highly unlikely that it will be possible to achieve turbulence in the cement slurry since it is so viscous and has such a high density. However, it may be possible to generate turbulence in the spacer and this will result in a more efficient displacement of the mud.

4.3 Single Stage Cementing Operation

The single stage primary cementing operation is the most common type of cementing operation that is conducted when drilling a well. The procedure for performing a single stage cementing operation (Figure 10) will be discussed first and then the procedure for conducting a **multiple stage and stinger cementing** operations will be discussed.

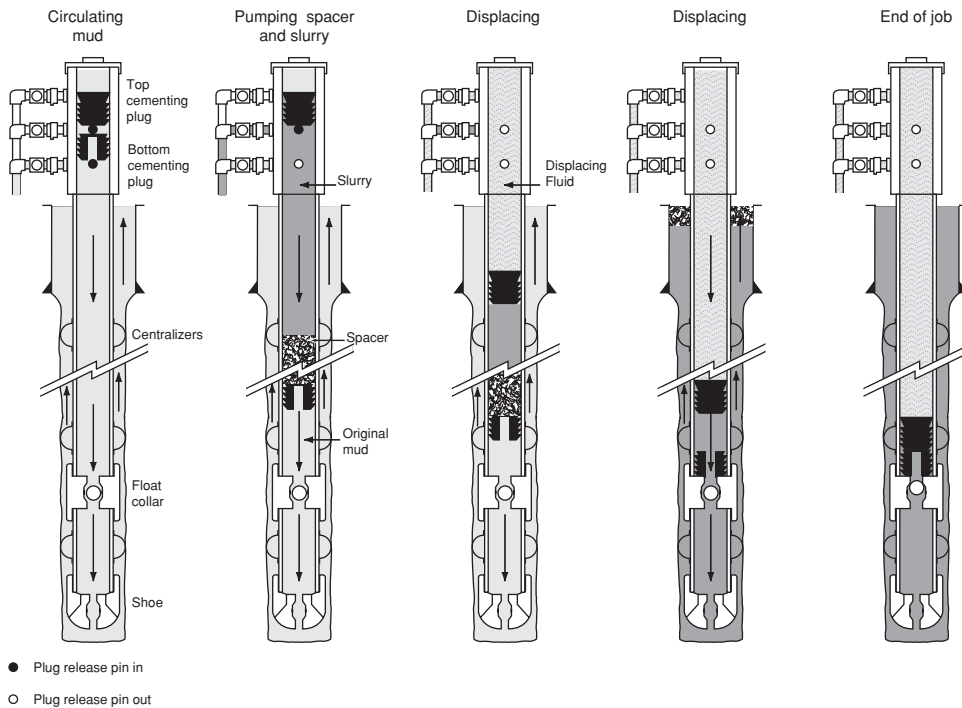

Figure 10 Single Stage Cementing Operation

In the case of the single stage operation, the casing with all of the required cementing accessories such as the float collar, centralisers etc. is run in the hole until the shoe is just a few feet off the bottom of the hole and the casing head is connected to the top of the casing. It is essential that the cement plugs are correctly placed in the cement head. The casing is then circulated clean before the cementing operation begins (at least one casing volume should be circulated). The first cement plug (**wiper plug**) shown in Figure 11, is pumped down ahead of the cement to wipe the inside of the casing clean. The spacer is then pumped into the casing. The spacer is followed by the cement slurry and this is followed by the second plug (**shut-off plug**) shown in Figure 12. When the wiper plug reaches the float collar its rubber diaphragm is ruptured, allowing the cement slurry to flow through the plug, around the shoe, and up into the annulus. At this stage the spacer is providing a barrier to mixing of the cement and mud. When the solid, shut-off plug reaches the float collar it lands on the wiper plug and stops the displacement process. The pumping rate should be slowed down as the shut-off plug approaches the float collar and the shut-off plug should be gently **bumped** into the bottom, wiper plug. The casing is often pressure tested at this point in the operation. The pressure is then bled off slowly to ensure that the float valves, in the float collar and/or casing shoe, are holding.

The displacement of the top plug is closely monitored. The volume of displacing fluid necessary to bump the plug should be calculated before the job begins. When the pre-determined volume has almost been completely pumped, the pumps should be slowed down to avoid excessive pressure when the plug is bumped. If the top plug does not bump at the calculated volume (allowing for compression of the mud) this may be because the top, shut-off plug has not been released. If this is the case, no more fluid should be pumped, since this would displace the cement around the casing shoe and up the annulus. Throughout the cement job the mud returns from the annulus should be monitored to ensure that the formation has not been broken down. If formation breakdown does occur then mud returns would slow down or stop during the displacement operation.

The single stage procedure can be summarised as follows:

1. Circulate the casing and annulus clean with mud (one casing volume pumped)
2. Release wiper plug
3. Pump spacer
4. Pump cement
5. Release shut-off plug
6. Displace with displacing fluid (generally mud) until the shut-off plug lands on the float collar
7. Pressure test the casing

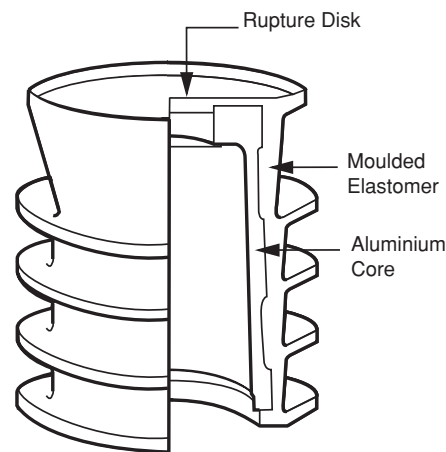

Figure 11 Bottom Plug (wiper plug)

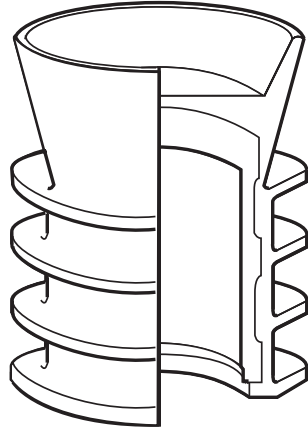

Figure 12 Top Plug (shut off plug)

4.4 Multi - Stage Cementing Operation

When a long intermediate string of casing is to be cemented it is sometimes necessary to split the cement sheath in the annulus into two, with one sheath extending from the casing shoe to some point above potentially troublesome formations at the bottom of the hole, and the second sheath covering shallower troublesome formations. The placement of these cement sheaths is known as a multi-stage cementing operation (Figure 13). The reasons for using a multi-stage operation are to reduce:

- Long pumping times
- High pump pressures
- Excessive hydrostatic pressure on weak formations due to the relatively high density of cement slurries.

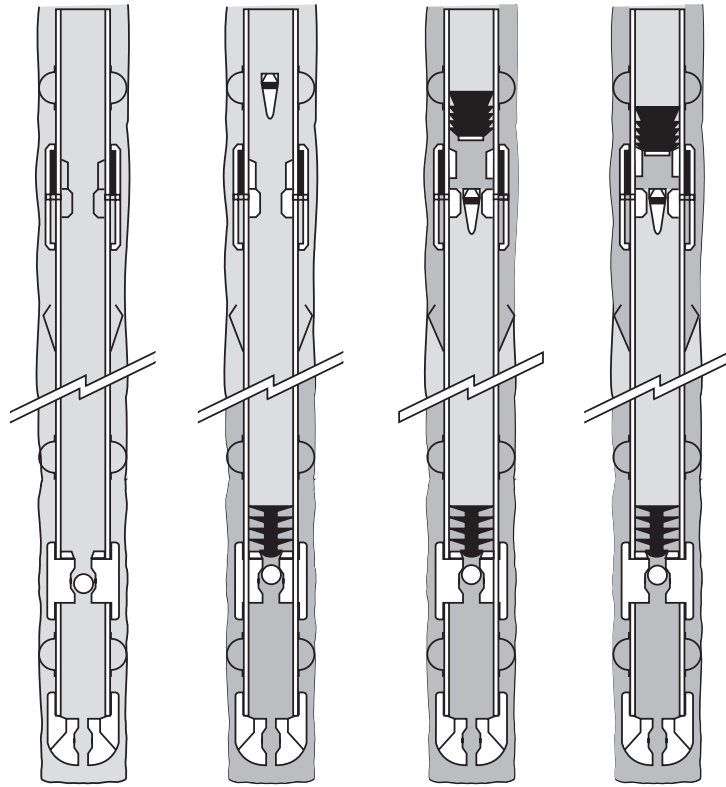

Figure 13 Multi-Stage Cementing Operation

The procedure for conducting a multi-stage operation is as follows:

First stage

The procedure for the first stage of the operation is similar to that described in Section 4.3 above, except that a wiper plug is not used and only a liquid spacer is pumped ahead of the cement slurry. The conventional shut-off plug is replaced by a plug with flexible blades. This type of shut-off plug is used because

it has to pass through the stage cementing collar which will be discussed below. It is worth noting that a smaller volume of cement slurry is used, since only the lower part of the annulus is to be cemented. The height of this cemented part of the annulus will depend on the fracture gradient of the formations which are exposed in the annulus (a height of 3000' - 4000' above the shoe is common).

Second stage

The second stage of the operation involves the use of a special tool known as a stage collar (Figure 14), which is made up into the casing string at a pre-determined position. The position often corresponds to the depth of the previous casing shoe. The ports in the stage collar are initially sealed off by the inner sleeve. This sleeve is held in place by retaining pins. After the first stage is complete a special dart is released from surface which lands in the inner sleeve of the stage collar. When a pressure of 1000 - 1500 psi is applied to the casing above the dart, and therefore to the dart, the retaining pins on the inner sleeve are sheared and the sleeve moves

down, uncovering the ports in the outer mandrel. Circulation is established through the stage collar before the second stage slurry is pumped.

The normal procedure for the second stage of a two stage operation is as follows:

- 1 Drop opening dart
- 2 Pressure up to shear pins
- 3 Circulate through stage collar whilst the first stage cement is setting
- 4 Pump spacer
- 5 Pump second stage slurry
- 6 Release closing plug
- 7 Displace plug and cement with mud
- 8 Pressure up on plug to close ports in stage collar and pressure test the casing.

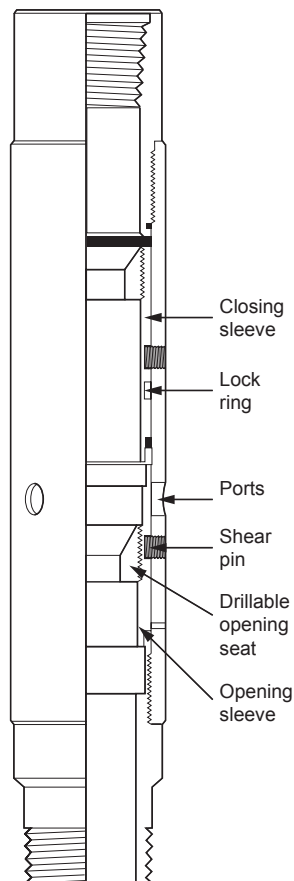

Figure 14 Multi-Stage Cementing Collar

To prevent cement falling down the annulus a cement basket or packer may be run on the casing below the stage collar. If necessary, more than one stage collar can be run on the casing so that various sections of the annulus can be cemented. One disadvantage of stage cementing is that the casing cannot be moved after the first stage cement has set in the lower part of the annulus. This increases the risk of channelling and a poor cement bond.

4.5 Inner string cementing

For large diameter casing, such as conductors and surface casing, conventional cementing techniques result in:

- The potential for cement contamination during pumping and displacement
- The use of large cement plugs which can get stuck in the casing
- Large displacement volumes
- Long pumping times
- Large volume of cement left inside the casing between float collar and shoe.

An alternative technique, known as a stinger cement job, is to cement the casing through a tubing or drillpipe string, known as a **cement stinger**, rather than through the casing itself.

In the case of a stinger cement job the casing is run as before, but with a special float shoe (Figure 15) rather than the conventional shoe and float collar. A special sealing adapter, which can seal in the seal bore of the seal float shoe, is attached to the cement stinger. Once the casing has been run, the cementing string (generally tubing or drillpipe), with the seal adapter attached, is run and stabbed into the float shoe. Drilling mud is then circulated around the system to ensure that the stinger and annulus are clear of any debris. The cement slurry is then pumped with liquid spacers ahead and behind the cement slurry. No plugs are used in this type of cementing operation since the diameter of the stinger is generally so small that contamination of the cement is unlikely if a large enough liquid spacer is used. The cement slurry is generally under-displaced so that when the seal adapter on the stinger is pulled from the shoe the excess cement falls down on top of the shoe. This can be subsequently drilled out when the next hole section is being drilled. Under-displacement however ensures that the cement slurry is not displaced up above the casing shoe, leaving spacer and drilling mud across the shoe. After the cement has been displaced, and the float has been checked for backflow, the cement stinger can be retrieved. This method is suitable for casing diameters of 13 3/8" and larger. The main disadvantage of this method is that for long casing strings rig time is lost in running and retrieving the inner string.

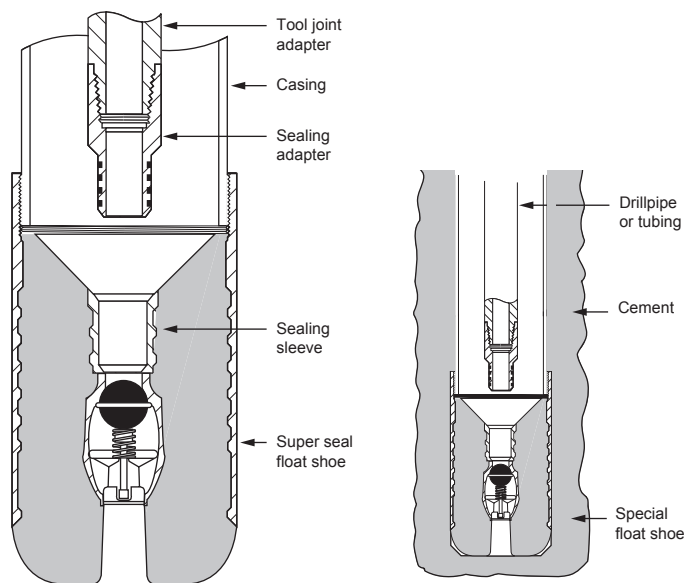

Figure 15 Stinger Cementing Operation

4.6 Liner cementing

Liners are run on drillpipe and therefore the conventional cementing techniques cannot be used for cementing a liner. Special equipment must be used for cementing these liners.

As with a full string of casing the liner has a float collar and shoe installed. In addition there is a landing collar, positioned about two joints above the float collar (Figure 16). A wiper plug is held on the end of the tailpipe of the running string by shear pins.

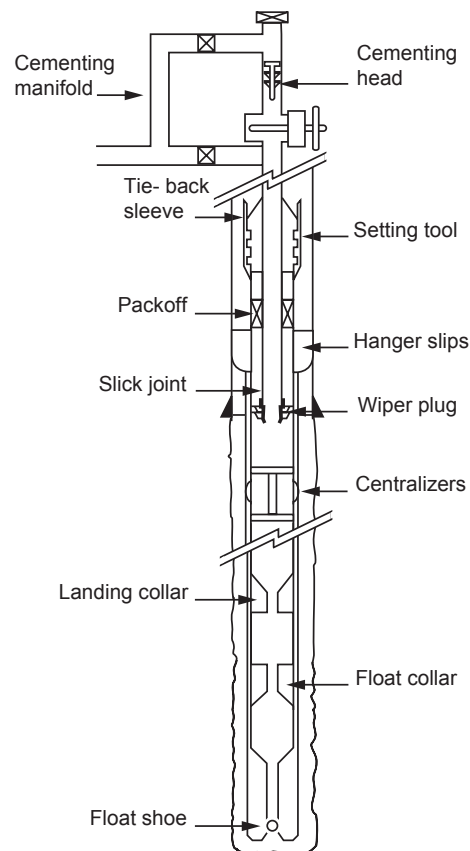

Figure 16 Liner Cementing Equipment

The liner is run on drillpipe and the hanger is set at the correct point inside the previous casing string. Mud is circulated to ensure that the liner and the annulus is free from debris, and to condition the mud. Before the cementing operation begins the liner setting tool is backed off to ensure that it can be recovered at the end of the cement job. The cementing procedure is as follows:

- 1 Pump spacer ahead of cement slurry
- 2 Pump slurry
- 3 Release pump down plug
- 4 Displace cement down the running string and out of the liner into the annulus
- 5 Continue pumping until the pump down plug lands on the wiper plug.
- 6 Apply pressure to the pump down plug and shear out the pins on the wiper plug. This releases the wiper plug
- 7 Both plugs move down the liner until they latch onto landing collar
- 8 Bump the plugs with 1000 psi pressure
- 9 Bleed off pressure and check for back flow

Since there is no bottom plug in front of the slurry the wiper plug cleans off debris and mud from the inside of the liner. This material will contaminate the cement immediately ahead of the wiper plug. The spacing between the landing collar and the shoe should be adequate to accommodate this contaminated cement, and thus prevent it from reaching the annulus where it would create a poor cement job around the shoe.



To promote a good cement job, cement in excess of that required to fill the annulus between the liner and the borehole is used. This excess cement will pass up around the liner top and settle on top of the liner running assembly. Once the cement is in place the liner setting tool is quickly picked up out of the liner. With the tail pipe above the liner top the excess cement can be reverse circulated out. The setting tool can then be retrieved.

In practice it is very difficult to obtain a good cement job on a liner. The main reasons for this are:

(a) Minimal annular clearances

A 7" OD liner run in an 8 1/2" hole gives a clearance of only 3/4" (assuming the liner is perfectly centred). This small clearance means that:

- It is difficult to run the liner (surge pressure)
- High pressure drops occur during circulation (lost circulation problems)
- It is difficult to centralise the liner
- Cement placement is poor (channeling)

(b) Mud contamination

When the cement comes in contact with mud or mud cake it may develop high viscosity. The increased pump pressure required to move this contaminated cement up the annulus may cause formation breakdown. Fluid loss additives must be used to prevent dehydration of the cement which may cause bridging in the annulus.

(c) Lack of pipe movement

Due to risk of sticking the setting tool, most operators want to be free of the liner before cementing begins. By disconnecting the setting tool the liner cannot be moved during the cement job. This lack of movement reduces the efficiency of cement placement. Due to these problems it is often necessary to carry out a remedial squeeze job at the top of the liner (Figure 17). It is becoming more common these days to remain latched on top of the liner and rotate the liner whilst the cement is being displaced into position. A special piece of liner running equipment, known as a rotating liner assembly, is used for this purpose.

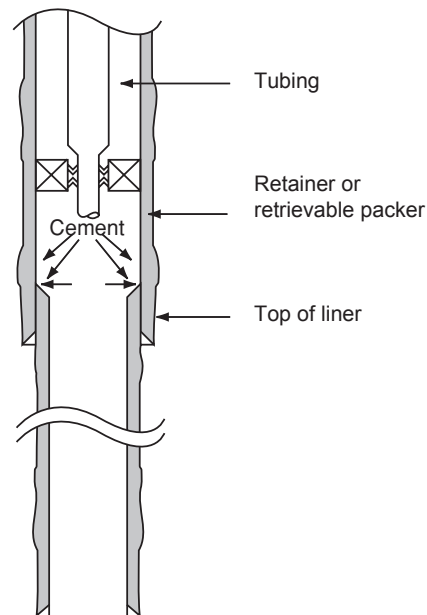

Figure 17 Remedial squeeze job on a liner

4.7 Recommendations for a good cement job

The main cause for poor isolation after a cement job is the presence of mud channels in the cement sheath in the annulus. These channels of gelled mud exist because the mud in the annulus has not been displaced by the cement slurry. This can occur for many reasons. The main reason for this is poor centralisation of the casing in the borehole, during the cementing operation. When mud is being displaced from the annulus the cement will follow the least path of resistance. If the pipe is not properly centralised the highest resistance to flow occurs where the clearance is least. This is where mud channels are most likely to occur (Figure 18).

In addition, field tests have shown that for a good cement bond to develop the formation should be in contact with the cement slurry for a certain time period while the cement is being displaced. The recommended contact time (pump past time) is about 10 minutes for most cement jobs. To improve mud displacement and obtain a good cement bond the following practices are recommended:

- Use centralisers, especially at critical points in the casing string
- Move the casing during the cement job. In general, rotation is preferred to reciprocation, since the latter may cause surging against the formation. A specially designed swivel may be installed between the cementing head and the casing to allow rotation. (Centralisers remain static and allow the casing to rotate within them.)
- Before doing the cement job, condition the mud (low PV, low YP) to ensure good flow properties, so that it can be easily displaced.

- Displace the spacer is in turbulent flow. This may not be practicable in large diameter casing where the high pump rates and pressures may cause erosion or formation breakdown.
- Use spacers to prevent mud contamination in the annulus.

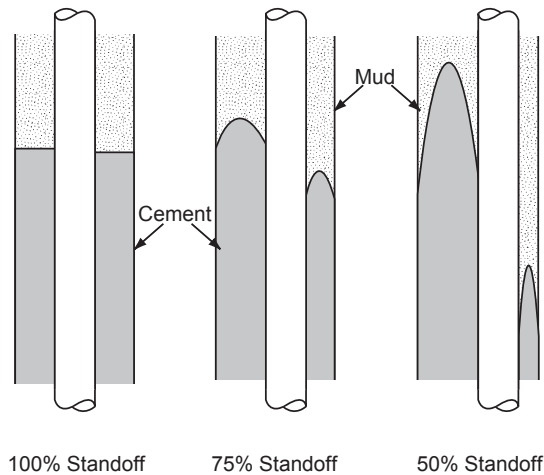

Figure 18 Effect of centralisation on channeling

5. SQUEEZE CEMENTING

Squeeze cementing is the process by which hydraulic pressure is used to force cement slurry through holes in the casing and into the annulus and/or the formation. Squeeze cement jobs are often used to carry out remedial operations during a workover on the well (Figure 3). The main applications of squeeze cementing are:

- To seal off gas or water producing zones, and thus maximise oil production from the completion interval
- To repair casing failures by squeezing cement through leaking joints or corrosion hole
- To seal off lost circulation zones
- To carry out remedial work on a poor primary cement job (e.g. to fill up the annulus)
- To prevent vertical reservoir fluid migration into producing zones (block squeeze)
- To prevent fluids escaping from abandoned zones.

During squeeze cementing the pores in the rock rarely allow whole cement to enter the formation since a permeability of about 500 darcies would be required for this to happen. There are two processes by which cement can be squeezed:

- High pressure squeeze - This technique requires that the formation be fractured, which then allows the cement slurry to be pumped into the fractured zone.
- Low pressure squeeze - During this technique the fracture gradient of the formation is not exceeded. Cement slurry is placed against the formation, and when pressure is applied the fluid content (filtrate) of the cement is squeezed into the rock, while the solid cement material (filter cake) builds up on the face of the formation.

5.1 High Pressure Squeeze

In a high pressure squeeze the formation is initially fractured (broken down) by a solids free breakdown fluid. A solids free fluid is used because a solids laden fluid such as drilling mud will build up a filter cake and prevent injection into the formation. Solids free fluids such as water or brine are recommended. The direction of the fracture depends on the rock stresses present in the formation. The fracture will occur along a plane perpendicular to the direction of the least compressive stress (Figure 19). In general, the vertical stress, due to the overburden, will be greater than the horizontal stresses. A vertical fracture is therefore more likely. In practice the fracture direction is difficult to predict since it may follow natural fractures in the formation. Since squeeze cementing is often used to isolate various horizontal zones a vertical fracture is of little use (vertical fluid movement is not prevented).

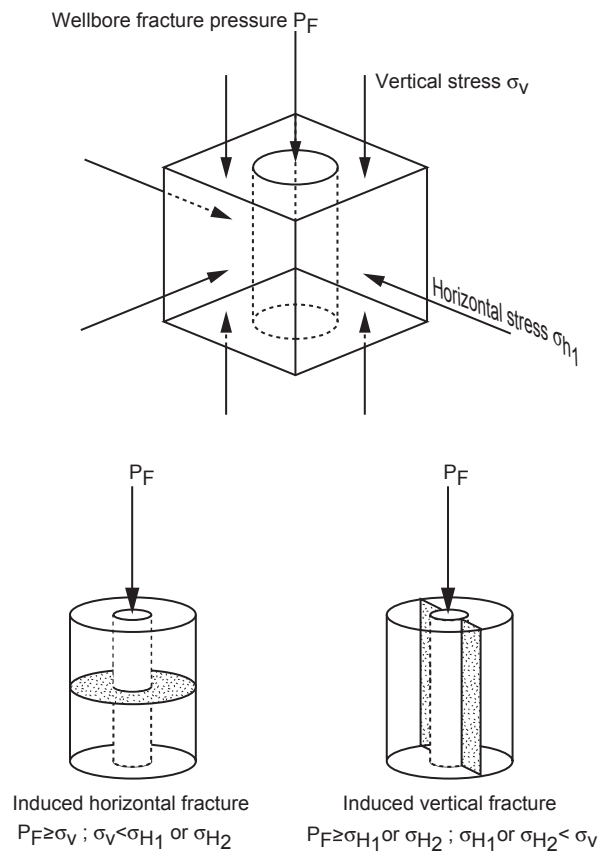

Effect of well depth and vertical-horizontal formation stresses on type of hydraulic fracture induced by injected fluid. Horizontal fracture pressure is less than overburden pressure, this is usually the case at depths greater than 3,000 feet.

Figure 19 Horizontal and vertical fracturing

After the formation is broken down a slurry of cement is spotted adjacent to the formation, and then pumped into the zone at a slow rate. The injection pressure should gradually build up as the cement fills up the fractured zone. After the cement has been squeezed the pressure is released to check for back flow. The disadvantages of this technique are:

- No control over the orientation of the fracture
- Large volumes of cement may be necessary to seal off the fracture
- Mud filled perforations may not be opened up by fracturing, so the cement may not seal them off effectively.

5.2 Low Pressure Squeeze

It is generally accepted that a low pressure squeeze is a more efficient method of sealing off unwanted perforated zones. In a low pressure squeeze the formation is not fractured. Instead a cement slurry is gently squeezed against the formation. A cement slurry consists of finely divided solids dispersed in a liquid. The solids are too large to be displaced into the formation. As pressure is applied, the liquid phase

is forced into the pores, leaving a deposit of solid material or filter cake behind. As the filter cake of dehydrated cement begins to build up, the impermeable barrier prevents further filtrate invasion. The filtrate must then be diverted to other parts of the perforated interval. This technique therefore creates an impermeable seal across the perforated zone. Fluid loss additives are important to perform this technique successfully. Neat cement has a high fluid loss, resulting in rapid dehydration which causes bridging before the other perforations are sealed off. Conversely a very low fluid loss means a slow filter cake build up and long cement placement time. Key factors which affect the build up of cement filter cake are:

- Fluid loss (generally 50 - 200 cc)
- Water to solids ratio (0.4 by weight)
- Formation characteristics (permeability, pore pressure)
- Squeeze pressure

Only a small volume of cement is required for a low pressure squeeze. Perforations must be free from mud or other plugging material. If the well has been producing for some time these perforations have to be washed out, sometimes with an acid solution. The general procedure for a low pressure squeeze job is:

- 1 Water is pumped into the zone to establish whether the formation can be squeezed (injectivity test). If water cannot be injected the squeeze job cannot be done without fracturing the formation
- 2 Spot the cement slurry at the required depth
- 3 Apply moderate squeeze pressure
- 4 Stop pumping and check for bleed off
- 5 Continue pumping until bleed off ceases for about 30 mins
- 6 Stop displacement of cement and hold pressure
- 7 Reverse circulate out excess cement from casing

A properly designed slurry will leave only a small cement node inside the casing after removing the excess cement. Throughout the procedure squeeze pressure is kept below the fracture gradient. A **running squeeze** is where the cement is pumped slowly and continuously until the final squeeze pressure is obtained. This is often used for repairing a primary cement job. A **hesitation squeeze** is where pumping is stopped at regular intervals to allow time for the slurry to dehydrate and form a filter cake. Small volumes of cement (1/4 - 1/2 bbl) are pumped each time separated by a delay of 10 - 15 mins. This technique is dangerous if the cement is still in contact with the drillpipe or packer.

5.3 Equipment Used for Squeeze Cementing

The high pressure and low pressure squeeze operations can be conducted with or without packers.

(a) Bradenhead squeeze

This technique involves pumping cement through drill pipe without the use of a packer (Figure 20). The cement is spotted at the required depth. The BOPs and the annulus are closed in and displacing fluid is pumped down, forcing the cement into the perforations, since it cannot move up the annulus. This is the simplest method of placing and squeezing cement, but has certain disadvantages:

- It is difficult to place the cement accurately against the target zone
- It cannot be used for squeezing off one set of perforations if other perforations are to remain open
- Casing is pressured up, and so squeeze pressure is limited by burst resistance

A Bradenhead squeeze is only generally used for a low-pressure squeeze job.

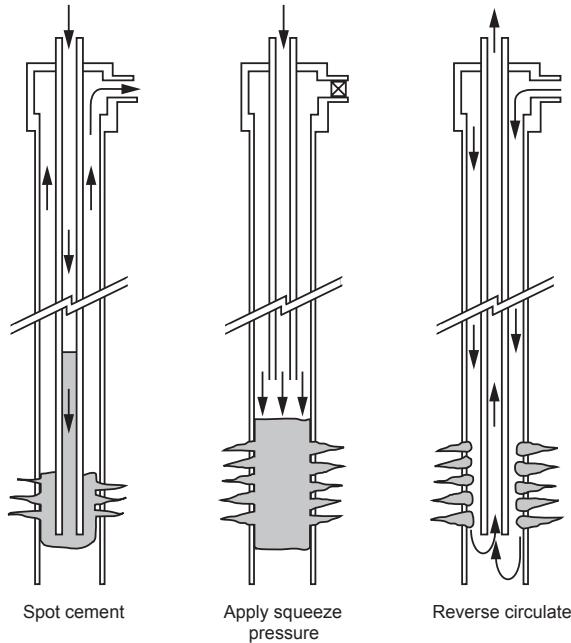

Schematic of Bradenhead squeeze technique normally used on low pressure formations. Cement is circulated into place down drill pipe (left), then the wellhead, or BOP, is closed (centre) and squeeze pressure is applied. Reverse circulating through perforations removes excess cement, or the plug can be drilled out.

Figure 20 Bradenhead technique

(b) Squeeze using a packer

The use of a packer makes it possible to place the cement more accurately, and apply higher squeeze pressures. The packer seals off the annulus, but allows communication between drill pipe and the wellbore beneath the packer. (Figure 21)

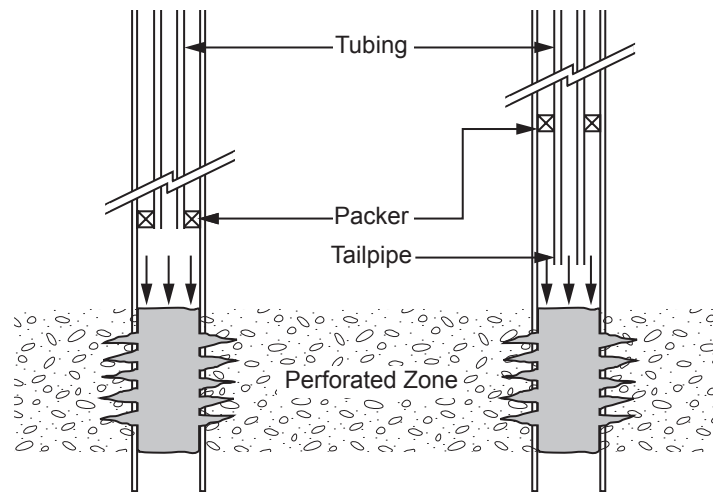

Figure 21 Squeeze cementing using a packer with or without a tailpipe

Two types of packer may be used in this type of operation:

(i) Drillable packer (cement retainer)

This type of packer contains a back pressure valve which will prevent the cement flowing back after the squeeze. These are mainly used for remedial work on primary cement jobs, or to close off water producing zones. The packer is run on drill pipe or wireline and set just above or between sets of perforations. When the cement has been squeezed successfully the drill pipe can be removed, closing the back pressure valve. The advantages of these packers are:

- Good depth control
- Back pressure valve prevents cement back flowing
- Drill pipe recovered without disturbing cement

The major disadvantage is that they can only be used once then drilled out.

(ii)Retrievable packer (cement retainer)

These can be set and released many times on one trip. This makes them suitable for repairing a series of casing leaks or selectively squeezing off sets of perforations. By-pass ports in the packer allow annular communication, but these ports are closed during the squeeze job. When the packer is released there may be some backflow, and the cement filter cake may be disturbed. If this happens the packer should be re-set and the squeeze pressure applied until the cement sets.

The basic procedure for squeezing with a retrievable packer is:

1. run the packer on drillpipe and set it at required depth with by-pass open
2. pump the cement slurry (keep back pressure on annulus to prevent cement falling

The packer setting depth should be considered carefully. If positioned too high above the perforations the slurry will be contaminated by the wellbore fluids and large volumes of fluid from below the packer will be pumped into the formation

ahead of the cement. If the packer is set too low it may become stuck in the cement. Generally the packer is set 30 - 50 ft above the perforations.

Sometimes a tail pipe is used below the packer to ensure that only cement is squeezed into the perforations, and there is less chance of getting stuck (Figure 21). **Bridge plugs** are often set in the wellbore, to isolate zones which are not to be treated. They seal off the entire wellbore, and hold pressure from above and below. Bridge plugs can either be drillable or retrievable.

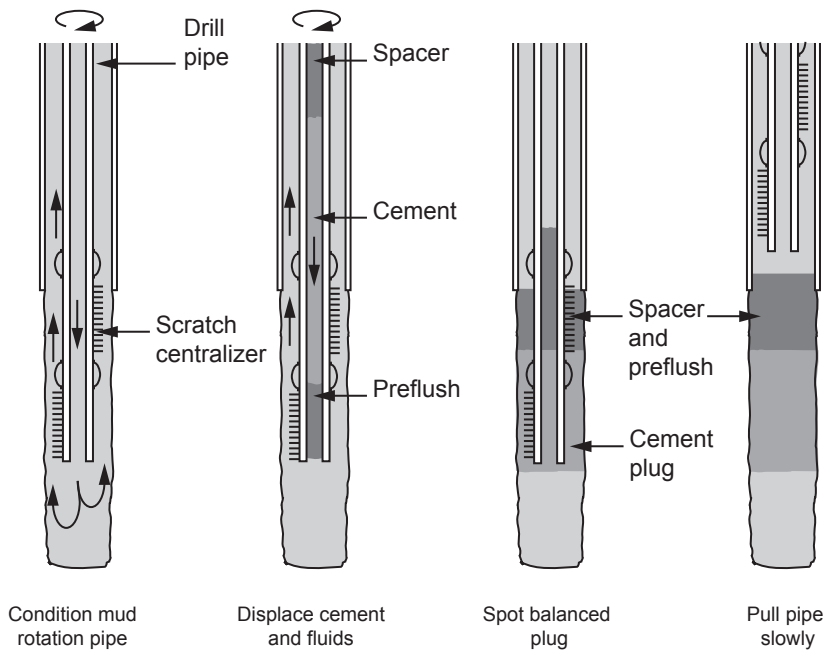

Figure 22 Balanced Plug Cementation

5.4 Testing the Squeeze Job

After the cement has hardened it must be pressure tested. The tests should include both positive and negative differential pressure. The following should be considered when making a test:

- A positive pressure test can be performed by closing the BOPs and pressuring up on the casing. (Do not exceed formation fracture gradient.)
- A negative pressure test (or **inflow test**) can be performed by reducing the hydrostatic pressure inside the casing. This can be done using a DST tool or displacing with the well to diesel. This test is more meaningful since mud filled perforations may hold pressure from the casing, but may become unblocked when pressure from the formation is applied.

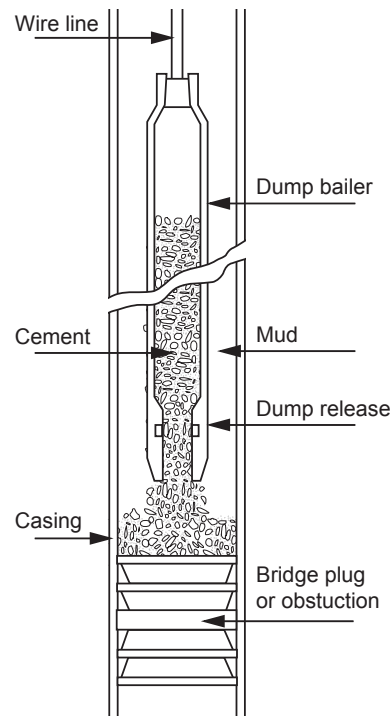

Figure 23 Dump Bailer Plug Cementation

6. CEMENT PLUGS

At some stage during the life of a well a cement plug may have to be placed in the wellbore. A cement plug is designed to fill a length of casing or open hole to prevent vertical fluid movement. Cement plugs may be used for:

- Abandoning depleted zones
- Seal off lost circulation zones
- Providing a kick off point for directional drilling (eg side-tracking around fish)
- Isolating a zone for formation testing
- Abandoning an entire well (government regulations usually insist on leaving a series of cement plugs in the well prior to moving off location).

The major problem when setting cement plugs is avoiding mud contamination during placement of the cement. Certain precautions should be taken to reduce contamination.

- Select a section of clean hole which is in gauge, and calculate the volume required (add on a certain amount of excess). The plug should be long enough to allow for some contamination (500' plugs are common). The top of the plug should be 250' above the productive zone
- Condition the mud prior to placing the plug
- Use a preflush fluid ahead of the cement
- Use densified cement slurry (ie less mixwater than normal)



After the cement has hardened the final position of the plug should be checked by running in and tagging the cement. There are three commonly used techniques for placing a cement plug:

(a) Balanced plug (Figure 22)

This method is aimed at achieving an equal level of cement in the drillpipe and annulus. Preflush, cement slurry and spacer fluid are pumped down the drillpipe and displaced with mud. The displacement continues until the level of cement inside and outside the drillpipe is the same (hence balanced). If the levels are not the same then a U-tube effect will take place. The drillpipe can then be retrieved leaving the plug in place.

(b) Dump bailer (Figure 23)

A dump bailer is an electrically operated device which is run on wireline. A permanent bridge plug is set below the required plug back depth. A cement bailer containing the slurry is then lowered down the well on wireline. When the bailer reaches the bridge plug the slurry is released and sits on top of the bridge plug. The advantages of this method are:

- High accuracy of depth control
- Reduced risk of contamination of the cement

the disadvantages are:

- Only a small volume of cement can be dumped at a time - several runs may be necessary
- It is not suitable for deep wells, unless retarders used.

7. EVALUATION OF CEMENT JOBS

A primary cement job can be considered a failure if the cement does not isolate undesirable zones. This will occur if:

- The cement does not fill the annulus to the required height between the casing and the borehole.
- The cement does not provide a good seal between the casing and borehole and fluids leak through the cement sheath to surface.
- The cement does not provide a good seal at the casing shoe and a poor leak off test is achieved

When any such failures occur some remedial work must be carried out. A number of methods can be used to assess the effectiveness of the cement job. These include:

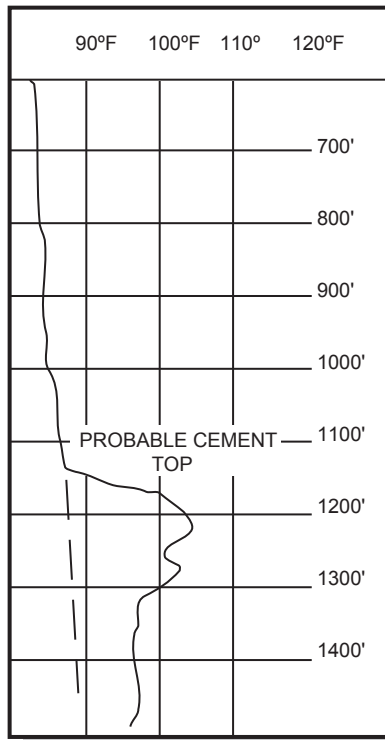

Figure 24 Estimating top of cement in annulus by running a temperature log

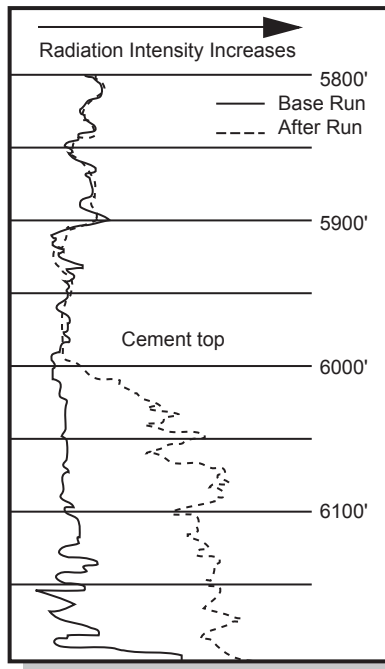

Figure 25 Estimating top of cement by running radioactivity log

Detecting Top of Cement (TOC)

(a) Temperature surveys (Figure 24)

This involves running a thermometer inside the casing just after the cement job. The thermometer responds to the heat generated by the cement hydration, and so can be used to detect the top of the cement column in the annulus.

(b) Radioactive surveys (Figure 25)

Radioactive tracers can be added to the cement slurry before it is pumped (Carnolite is commonly used). A logging tool is then run when the cement job is complete. This tool detects the top of the cement in the annulus, by identifying where the radioactivity decreases to the background natural radioactivity of the formation.

Detecting Top of Cement (TOC) and the Measuring the Quality of the Cement Bond

(a) Cement bond logs (CBL)

The cement bond logging tools have become the standard method of evaluating cement jobs since they not only detect the top of cement, but also indicate how good the cement bond is. The CBL tool is basically a sonic tool which is run on wireline. The distance between transmitter and receiver is about 3 ft (Figure 26). The logging tool must be centralised in the hole to give accurate results. Both the time taken for the signal to reach the receiver, and the amplitude of the returning signal, give an indication of the cement bond. Since the speed of sound is greater in casing than in the formation or mud the first signals which are received at the receiver are those which travelled through the casing (Figure 27). If the amplitude (E_1) is large (strong signal) this indicates that the pipe is free (poor bond). When cement is firmly bonded to the casing and the formation the signal is attenuated, and is characteristic of the formation behind the casing.

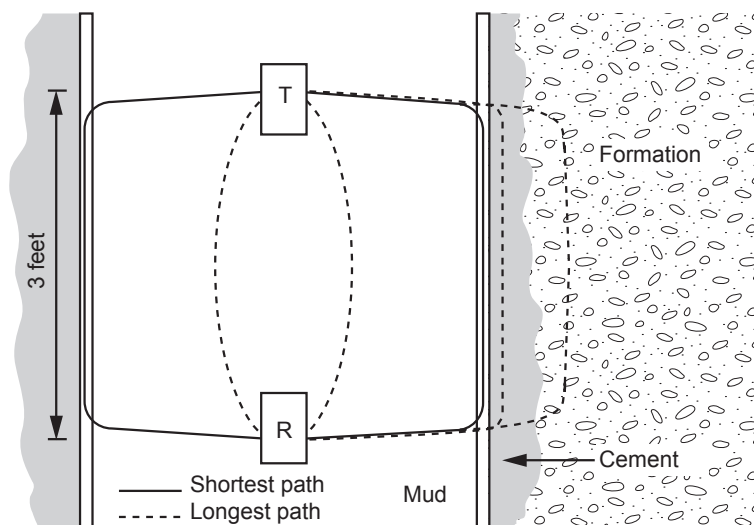

Figure 26 Schematic of CBL tool

(b) the Variable Density Log (VDL)

The CBL log usually gives an amplitude curve and provides an indication of the quality of the bond between the casing and cement. A VDL (variable density log), provides the wavetrain of the received signal (Figure 28), and can indicate the quality of the cement bond between the casing and cement, and the cement and the formation. The signals which pass directly through the casing show up as parallel, straight lines to the left of the VDL plot. A good bond between the casing and cement and cement and formation is shown by wavy lines to the right of the VDL plot. The wavy lines correspond to those signals which have passed into and through the formation before passing back through the cement sheath and casing to the receiver. If the bonding is poor the signals will not reach the formation and parallel lines will be recorded all across the VDL plot.

The interpretation of CBL logs is still controversial. There is no standard API scale to measure the effectiveness of the cement bond. There are many factors which can lead to false interpretation:

- During the setting process the velocity and amplitude of the signals varies significantly. It is recommended that the CBL log is not run until 24 - 36 hours after the cement job to give realistic results.
- Cement composition affects signal transmission
- The thickness of the cement sheath will cause changes in the attenuation of the signal
- The CBL will react to the presence of a microannulus (a small gap between casing and cement). The microannulus usually heals with time and is not a critical factor. Some operators recommend running the CBL under pressure to eliminate the microannulus effect

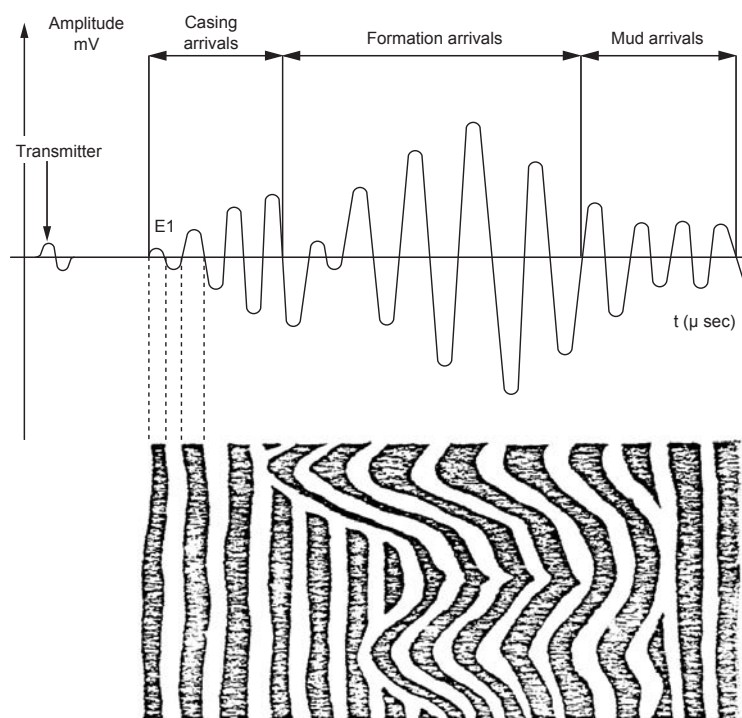

Figure 27 Signals picked up by receiver

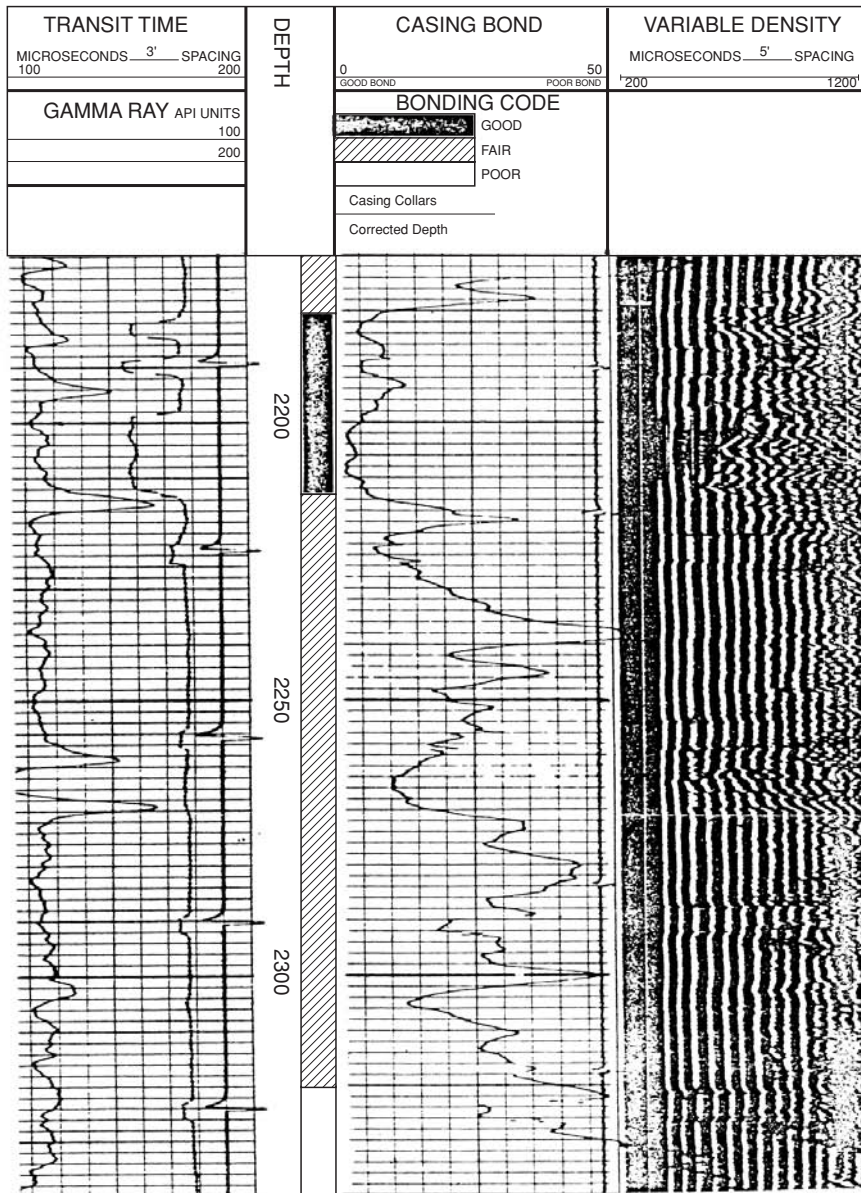

Figure 28 Example of CBL/VDL

CEMENTING CALCULATIONS

The following calculations must be undertaken prior to a cementation operation:

- Slurry Requirements
- No. of sacks of Cement
- Volume of Mixwater
- Volume of Additives
- Displacement Volume Duration of Operation

These calculations will form the basis of the cementing programme. They should be performed in this sequence as will be seen below.

1. Cement Slurry Requirements :

Sufficient cement slurry must be mixed and pumped to fill up the following (see Fig 29):

- A - the annular space between the casing and the borehole wall,
- B - the annular space between the casings (in the case of a two stage cementation operation)
- C - the openhole below the casing (rathole)
- D - the shoetrack

The volume of slurry that is required will dictate the amount of dry cement, mixwater and additives that will be required for the operation.

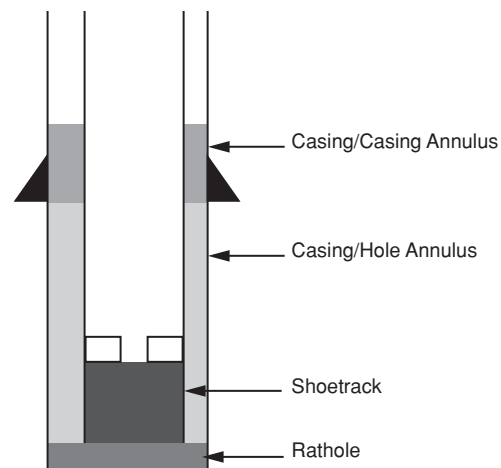

Figure 29 Single Stage Cementing Operation

In addition to the calculated volumes an excess of slurry will generally be mixed and pumped to accommodate any errors in the calculated volumes. These errors may arise due to inaccuracies in the size of the borehole (due to washouts etc.). It is common to mix an extra 10-20% of the calculated openhole volumes to accommodate these inaccuracies.

The volumetric capacities (quoted in bbls/linear ft or cuft/linear ft or m³/m) of the annuli, casings, and open hole are available from service company cementing tables.. These volumetric capacities can be calculated directly but the cementing tables are simple to use and include a more accurate assessment of the displacement of the casing for instance and the capacities based on nominal diameters.

In the case of a two stage operation (Figure 30) the volume of slurry used in the first stage of the operation is the same as that for a single stage operation. The second stage slurry volume is the slurry required to fill the annulus between the casing and hole (or casing/casing if the multi-stage collar is inside the previous shoe) annular space.

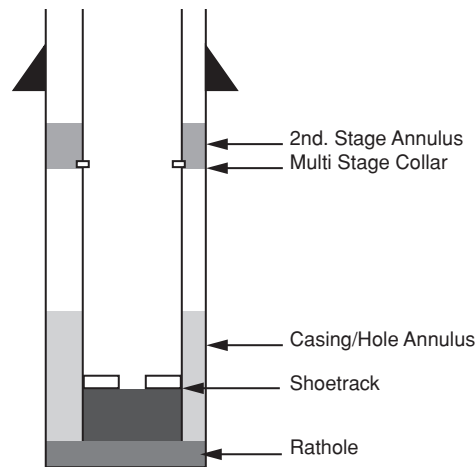

Figure 30 Two-Stage Cementing Operation

2. Number of Sacks of Cement

Although cement and other dry chemicals are delivered to the rigsite in bulk tanks the amount of dry cement powder is generally quoted in terms of the number of sacks (sxs) of cement required. Each sack of cement is equivalent to 1 cu. ft of cement.

The number of sacks of cement required for the cement operation will depend on the amount of slurry required for the operation (calculated above) and the amount of cement slurry that can be produced from a sack of cement. The amount of cement slurry that can be produced from a sack of cement, known as the yield of the cement, will depend on the type of cement powder (API classification) and the amount of mixwater mixed with the cement powder. The latter will also depend on the type of cement and will vary with pressure and temperature. The number of sacks of cement required for the operation can be calculated from the following

$$\text{No. of Sacks} = \frac{\text{Total Volume of Slurry}}{\text{Yield of Cement}}$$

3. Mixwater Requirements

The mixwater required to hydrate the cement powder will be prepared and stored in specially cleaned mud tanks. The amount of mixwater required for the operation will depend on the type of cement powder used. The volume of mixwater required for the cement slurry can be calculated from:

$$\text{Mixwater Vol.} = \text{Mixwater per sack} \times \text{No. sxs}$$

4. Additive Requirements

There are a variety of additives which may be added to cement. These additives may be delivered to the rigsite as liquid or dry additives. The amount of additive is generally quoted as a percentage of the cement powder used. Since each sack of cement weighs 94 lbs, the amount of additive can be quoted in weight (lbs) rather than volume. This can then be related to the number of sacks of additive. The number of sacks of additive can be calculated from:

Number of sacks of additive = No. sxs Cement x % Additive

Weight of additive = No. sxs of Additive x 94(lb/sk)

The amount of additive is always based on the volume of cement to be used.

5. Displacement Volume

The volume of mud used to displace the cement from the cement stinger or the casing during the cementing operation is commonly known as the displacement volume. The displacement volume is dependant on the way in which the operation is conducted.

a. Stinger Operation :

The displacement volume can be calculated from the volumetric capacity of the cement stinger and the depth of the casing shoe. The cement is generally **under displaced** by 1-2 bbls of liquid.

Displacement Vol. = Volumetric capacity of stinger x Depth of Casing - 1bbl

b. Conventional Operation :

In a conventional cementing operation the displacement volume is calculated from the volumetric capacity of the casing and the depth of the float collar in the casing.

Displacement Vol. = Volumetric Capacity of Casing x Depth of Float Collar

c. Two-stage Cementing Operation:

In a two stage operation the first stage is firstly displaced by a volume of mud, calculated in the same way as a single stage cement operation described above. The second stage displacement is then calculated on the basis of the volumetric capacity of the casing and the depth of the second stage collar.

Ist Stage :

Displacement Vol. = Volumetric Capacity of Casing x Depth of Float Collar

2nd stage :

Displacement Vol. = Volumetric Capacity of Casing x Depth of Multi-stage collar

The amount of mud to be pumped during the displacement operation may be quoted in terms of a volume (bbls, cuft etc.) or in terms of the number of strokes of the mud pump required to pump the mud volume. It will therefore be necessary to determine the volume of fluid pumped with each stoke of the pumps (vol./stroke). The number of strokes required to displace the cement will therefore be calculated from:

Number of strokes = Volume of displacement fluid/Vol. of fluid per stroke



6. Duration of Operation

The duration of the operation will be used to determine the required setting time for the cement formulation. The duration of the operation will be calculated on the basis of the mixing rate for the cement, the pumping rate for the cement slurry and the pumping rate for the displacing mud. An additional period of time, known as a contingency time, is added to the calculated duration to account for any operational problems during the operation. This contingency is generally 1 hour in duration. The duration of the operation can be calculated from:

$$\text{Duration} = \frac{\text{Vol. of Slurry}}{\text{Mixing Rate}} + \frac{\text{Vol. of Slurry}}{\text{Pumping Rate}} + \frac{\text{Displacement Vol.}}{\text{Displacement Rate}} + \text{Contingency Time (1hr.)}$$

EXAMPLE OF CEMENT VOLUME CALCULATIONS

The 9 5/8" Casing of a well is to be cemented in place with a single stage cementing operation. The appropriate calculations are to be conducted prior to the operation. The details of the operation are as follows:

9 5/8" casing set at: 13800',
 12 1/4" hole: 13810'
 13 3/8" 68 lb/ft casing set at : 6200'
 TOC outside 9 5/8" casing: 3000' above shoe
 Assume gauge hole, add 20% excess in open hole

The casing is to be cemented with class G cement with the following additives:

0.2% D13R (retarder)
 1 % D65 (friction reducer)
 Slurry density = 15.9 ppg

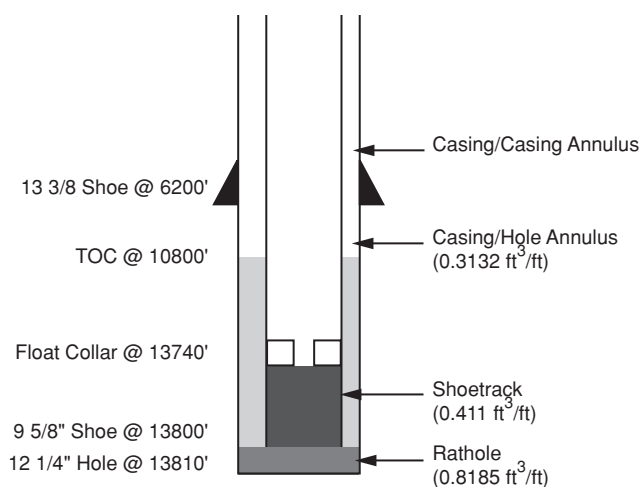

Figure 31 Example of Cementing Calculation

1. Slurry Volume Between The Casing and Hole:

$$\begin{aligned}
 9\ 5/8'' \text{ csg/ } 12\ 1/4'' \text{ hole capacity} &= 0.3132 \text{ ft}^3/\text{ft} \\
 \text{annular volume} &= 3000 \times 0.3132 \\
 &= 939.6 \text{ ft}^3 \\
 \text{plus } 20\% \text{ excess} &= 187.9 \text{ ft}^3 \\
 &= 1127.5 \text{ ft}^3 \quad \Rightarrow 1128 \text{ ft}^3
 \end{aligned}$$

2. Slurry Volume Below The Float Collar:

$$\begin{aligned}
 \text{Cap. of } 9\ 5/8'', 47 \text{ lb/ft csg} &= 0.4110 \text{ ft}^3/\text{ft} \\
 \text{shoetrack vol.} &= 60 \times 0.411 \\
 \text{Total} &= 25 \text{ ft}^3
 \end{aligned}$$

3. Slurry volume in the rathole

$$\begin{aligned}
 \text{Cap. of } 12\ 1/4'' \text{ hole} &= 0.8185 \text{ ft}^3/\text{ft} \\
 \text{rathole vol.} &= 10 \times 0.8185 \\
 &= 8.2 \text{ ft}^3 \\
 \text{plus } 20\% &= 1.6 \text{ ft}^3 \\
 \text{Total} &= 9.8 \text{ ft}^3 \quad \Rightarrow 10 \text{ ft}^3
 \end{aligned}$$

$$\begin{aligned}
 \text{Total cement slurry vol.} &= 1128 + 25 + 10 \\
 &= \mathbf{1163 \text{ ft}^3}
 \end{aligned}$$

4. Amount of cement and mixwater

$$\begin{aligned}
 \text{Yield of class G cement for density of } 15.9 \text{ ppg} &= 1.14 \text{ ft}^3/\text{sk} \\
 \text{mixwater requirements} &= 4.96 \text{ gal/sk}
 \end{aligned}$$

$$\begin{aligned}
 \text{No. of sks of cement} &= \frac{1163}{1.14} &= \mathbf{1020 \text{ sk}}
 \end{aligned}$$

$$\begin{aligned}
 \text{Mixwater required} &= 1020 \times 4.96 \text{ gal} \\
 &= 5059 \text{ gal} &= \mathbf{120 \text{ bbls}}
 \end{aligned}$$

5. Amount of Additives:

$$\begin{aligned}
 \text{Retarder D13R (0.2\% by weight)} & \\
 &= \frac{0.2}{100} \times 1020 \times 94 \text{ (lb/sk)} = \mathbf{192 \text{ lb}}
 \end{aligned}$$

$$\begin{aligned}
 \text{Friction reducer (1.0\% D65 by weight)} & \\
 &= \frac{1}{100} \times 1020 \times 94 \text{ (lb/sk)} = \mathbf{959 \text{ lb}}
 \end{aligned}$$



6. Displacement Volume:

Displacement vol. = vol between cement head and float collar
 = $0.4110 \times 13740 = 5647 \text{ ft}^3 = 1006 \text{ bbl}$
 (add 2 bbl for surface line)
= 1008 bbl

For Nat. pump 12-P-160, 7" liner 97% eff, 0.138 bbl/stk

No. of strokes = $\frac{1008}{0.138} = 7300 \text{ strokes}$

EXERCISE 1 Cementing Calculations - Stinger Cementation

The 20" casing of a well is to be cemented to surface with class 'C' high early strength cement + 6% Bentonite using a stinger type cementation technique. Calculate the following for the 20" casing cementation :

- The number of sacks of cement required (allow 100% excess in open hole).
- The volume of mixwater required.
- An estimate of the time taken to carry out the job. (Note: use an average mixing/pumping time of 5 bbls/min.)

30" Casing	: 0 - 400 ft.
20" Casing 94 lb/ft	: 0 - 500 ft
20" Casing 133 lb/ft	: 500 - 1500 ft.
26" Open hole Depth	: 1530 ft.
Stinger	: 5" 19.5" drillpipe

Class 'C' Cement + 6% Bentonite	
Density	: 13.1 ppg
Yield	: 1.88 ft ³ /sk
Mixwater Requirements	: 1.36 ft ³ /sk

EXERCISE 2 Cementing Calculations - Two Stage Cementation

The 13 3/8" casing string of a well is to be cemented using class 'G' cement. Calculate the following:

- The required number of sacks of cement for a 1st stage of 700 ft. and a 2nd stage of 500 ft. (Allow 20% excess in open hole)
- The volume of mixwater required for each stage.
- The total hydrostatic pressure exerted at the bottom of each stage of cement (assume a 10 ppg mud is in the well when cementing).

d. The displacement volume for each stage.

20" Casing shoe		: 1500 ft
13 3/8" Casing	77 lb/ft	: 0 - 1000 ft
13 3/8" Casing	72 lb/ft	: 1000 - 7000 ft.
17 1/2" open hole Depth		: 7030 ft.
Stage Collar Depth		: 1500 ft.
Shoetrack		: 60 ft.

<u>Cement stage 1</u>	(7000-6300 ft.)	
Class 'G'		
Density		: 15.9 ppg
Yield		: 1.18 ft ³ /sk
Mixwater Requirements		: 0.67 ft ³ /sk

<u>Cement stage 2</u>	(1500-1000 ft.)	
Class 'G' + 8% bentonite		
Density		: 13.3 ppg
Yield		: 1.89 ft ³ /sk
Mixwater Requirements		: 1.37 ft ³ /sk

VOLUMETRIC CAPACITIES

	bbls/ft	ft ³ /ft
Drillpipe		
5" drillpipe :	0.01776	0.0997
Casing		
13 3/8" 72 lb/ft :	0.1480	0.8314
13 3/8" 77 lb/ft :	0.1463	0.8215
Open Hole		
26" Hole	0.6566	3.687
17 1/2" Hole	0.2975	1.6703
Annular Spaces		
26" hole x 20" Casing:	0.2681	1.5053
17 1/2" hole x 13 3/8" Casing:	0.1237	0.6946
30" Casing x 20" Casing:	0.3730	2.0944
20" Casing x 13 3/8" Casing:	0.1816	1.0194



SOLUTION TO EXERCISES

Exercise 1 Cementing Calculations - Stinger Cementation

The surface (20") casing of a well is normally cemented to surface (continue pumping cement until it is seen at surface). In order to determine the volume of slurry required one calculates the annular space between the conductor (30") and the surface string (20") and between the surface string and the openhole. The volume of rathole is added to the above and the slurry volume is translated via the yield of the cement recipe to the number of sacks of cement required for the entire job.

The volume of mixwater required is specified in the slurry recipe in terms of cu ft. per sack of cement and will be determined on the basis of a required cement strength, setting time and allowable free water content.

The time required for the cement job will include the mixing and pumping time (assuming that the slurry is not batch mixed), the time to displace the cement from the cement stinger (since this type of job would normally be carried out using a stinger cementation technique) and 1 hr. contingency time to allow for operational problems during the job. The operation duration will be used to design the slurry so that the cement is set as soon as possible after the job is complete.

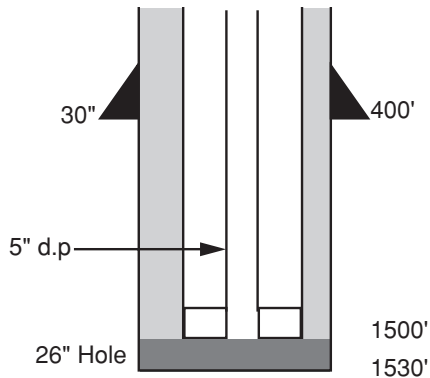

a. No. sxs cement

Slurry volume between the 20" casing and 30" casing:

$$\begin{aligned}
 &20" \text{ casing}/30" \text{ casing capacity} &&= 2.0944 \text{ ft}^3/\text{ft} \\
 &\text{annular volume} &&= 400 \times 2.0944 \\
 &&&= 838 \text{ ft}^3
 \end{aligned}$$

Slurry volume between the casing and hole:

$$\begin{aligned}
 &20" \text{ csg}/26" \text{ hole capacity} &&= 1.5053 \text{ ft}^3/\text{ft} \\
 &\text{annular volume} &&= 1100 \times 1.5053 \\
 &&&= 1656 \text{ ft}^3
 \end{aligned}$$

$$\begin{aligned}
 &\text{plus } 100\% \text{ excess} &&= 1656 \text{ ft}^3 \\
 &\text{Total} &&= 3312 \text{ ft}^3
 \end{aligned}$$

Slurry volume in the rathole
 Cap. of 26" hole = 3.687 ft³/ft
 rathole vol. = 30 x 3.687
 = 111 ft³
 plus 100% = 111 ft³
 Total = 222 ft³

TOTAL SLURRY VOL. : = **4372 ft³**

Yield of class C cement for density of 13.1 ppg = 1.88 ft³/sk

TOTAL No. SXS CEMENT : **4372/1.88** = **2326 sxs**

b. Mixwater Requirements

Mixwater requirements for class C cement with 6% Bentonite
 = 1.36 ft³/sk

Mixwater required = **2326 x 1.36**
 = **3163 ft³**

c. Displacement Time

Total Displacement time = Time to mix and pump cement + time to displace cement

Total Volume of Cement = 4372 ft³
 = 779 bbl

Displacement vol. = vol to displace down drillpipe leaving 1 bbl under displaced

d.p. capacity = 0.01776 bbl/ft
 Displacement to 1500 ft = 0.01776 x 1500
 = 26.6 bbl

(underdisplace by 1 bbl) = 25.6 bbl

Total Volume to mix and displace = 779 + 25.6 = 804.6 bbls

Total time @ 5 bbl/min = **804.6/5**
 = **160.9 = 2.7 hrs**



Exercise 2 Cementation Calculations - Two Stage Cementation

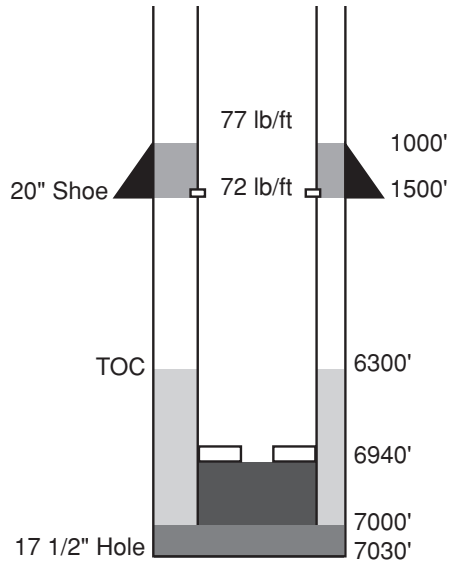

a. No. sxs cement

Stage 1:

Slurry volume between the casing and hole:

$$\begin{aligned}
 &13 \frac{3}{8} \text{ csg} / 17 \frac{1}{2} \text{ hole capacity} &&= 0.6946 \text{ ft}^3/\text{ft} \\
 &\text{annular volume} &&= 700 \times 0.6946 \\
 &&&= 486 \text{ ft}^3 \\
 &\text{plus 20\% excess} &&= 97 \text{ ft}^3 \\
 &\text{Total} &&= 583 \text{ ft}^3
 \end{aligned}$$

Slurry volume below the float collar:

$$\begin{aligned}
 &\text{Cap. of } 13 \frac{3}{8} \text{, } 72 \text{ lb/ft csg} &&= 0.08314 \text{ ft}^3/\text{ft} \\
 &\text{shoetrack vol.} &&= 60 \times 0.08314 \\
 &\text{Total} &&= 50 \text{ ft}^3
 \end{aligned}$$

Slurry volume in the rathole

$$\begin{aligned}
 &\text{Cap. of } 17 \frac{1}{2} \text{ hole} &&= 1.6703 \text{ ft}^3/\text{ft} \\
 &\text{rathole vol.} &&= 30 \times 1.6703 \\
 &&&= 50.11 \text{ ft}^3 \\
 &\text{plus 20\%} &&= 10.02 \text{ ft}^3 \\
 &\text{Total} &&= 60 \text{ ft}^3
 \end{aligned}$$

$$\text{TOTAL SLURRY VOL. STAGE 1 :} = 693 \text{ ft}^3$$

Yield of class G cement for density of 15.9 ppg = 1.18 ft³/sk

$$\text{TOTAL No. SXS CEMENT STAGE 1:} \quad 693/1.18 = 587 \text{ sxs}$$

Stage 2:

$$\begin{aligned}
 20'' \text{ csg/ } 13 \frac{3}{8}'' \text{ csg} &= 1.0194 \text{ ft}^3/\text{ft} \\
 \text{annular volume} &= 500 \times 1.0194 \\
 &= 508 \text{ ft}^3
 \end{aligned}$$

TOTAL SLURRY VOL. STAGE 2 : **508 ft³**

Yield of class G cement for density of 13.2 ppg = 1.89 ft³/sk

TOTAL No. SXS CEMENT STAGE 2: **508/1.89 = 269 sxs**

b. Mixwater Requirements

Stage 1:

$$\begin{aligned}
 \text{mixwater requirements for class G cement for density of } 15.9 \text{ ppg} &= 0.67 \text{ ft}^3/\text{sk}
 \end{aligned}$$

Mixwater required = **587 x 0.67**
= **393 ft³**

Stage 2:

$$\begin{aligned}
 \text{mixwater requirements for class G cement for density of } 13.2 \text{ ppg} &= 1.37 \text{ ft}^3/\text{sk}
 \end{aligned}$$

Mixwater required = 270 x 1.37
= **370 ft³**

c. Hydrostatic Head

Stage 1:

$$\begin{aligned}
 \text{Mud Hydrostatic (0 - 6300 ft) + Cement Hydrostatic (6300 - 7030 ft)} \\
 = 6300 \times 10 \times 0.052 + 730 \times 15.9 \times 0.052 \\
 = \mathbf{3880 \text{ psi}}
 \end{aligned}$$

Stage 2:

$$\begin{aligned}
 \text{Mud Hydrostatic (0 - 1000 ft) + Cement Hydrostatic (1000 - 1500 ft)} \\
 = 1000 \times 10 \times 0.052 + 500 \times 13.2 \times 0.052 \\
 = \mathbf{863 \text{ psi}}
 \end{aligned}$$

A knowledge of the hydrostatic pressure exerted by the cement slurry when it is placed will ensure that the formation fracture pressure will not be exceeded during the cement job.



d. Displacement Volumes

Stage 1:

$$\begin{aligned} \text{Displacement vol.} &= \text{vol between cement head and float collar} \\ &= 0.1463 \times 1000 \text{ (77 lb/ft casing)} + 0.148 \times 5940 \text{ (72 lb/ft casing)} \\ &= 1025 \text{ bbl} \\ &\text{(add 2 bbl for surface line)} \qquad \qquad \qquad = \mathbf{1027 \text{ bbl}} \end{aligned}$$

Stage 2:

$$\begin{aligned} \text{Displacement vol.} &= \text{vol between cement head and stage collar} \\ &= 0.1463 \times 1000 \text{ (77 lb/ft casing)} + 0.148 \times 500 \text{ (72 lb/ft casing)} \\ &= 220 \text{ bbl} \\ &\text{(add 2 bbl for surface line)} \qquad \qquad \qquad = \mathbf{222 \text{ bbl}} \end{aligned}$$

Drilling Fluids 9

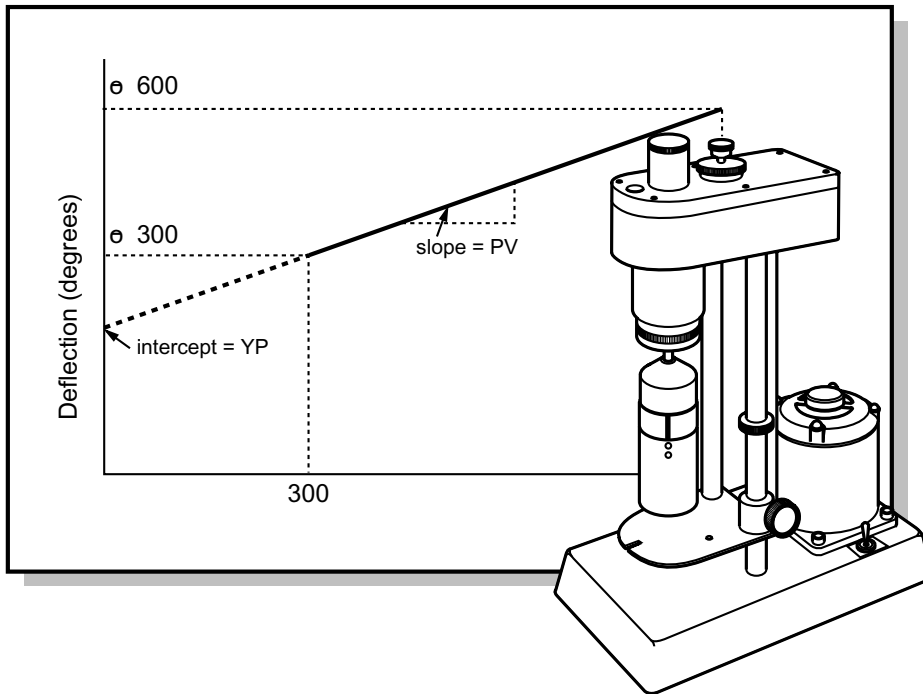

CONTENTS

1. INTRODUCTION

- 1.1 Functions of a Drilling Fluid
- 1.2 Types of Drilling Fluid
- 1.3 Historical Development of Drilling Fluids
- 1.4 Composition of Mud

2. FIELD TESTS ON DRILLING FLUIDS

- 2.1 Mud density
- 2.2 Viscosity
- 2.3 Gel Strength
- 2.4 Filtration
- 2.5 Sand Content
- 2.6 Liquid and Solid Content
- 2.7 pH Determination
- 2.8 Alkalinity
- 2.9 Chloride content
- 2.10 Activity(a_w)
- 2.11 Cation Exchange Capacity

3. WATER BASED MUD

- 3.1 Clay Chemistry
- 3.2 Additives to WBM's
- 3.3 Special Types of Water Based Muds
 - 3.3.1 Inhibited Muds
 - 3.3.2 Brine Drilling Fluid

4. OIL-BASED MUDS

- 4.1 Water in oil emulsions
- 4.2 Wettability control
- 4.3 Balanced activity
- 4.4 Viscosity control
- 4.5 Filtration control

5. SOLIDS CONTROL

- 5.1 Solids Control Equipment
- 5.2 Solids Control Systems





LEARNING OBJECTIVES:

Having worked through this chapter the student will be able to:

General:

- List and describe the functions of drilling fluids and the properties which influence the capability of the fluid to achieve these functions.
- Describe the most important properties of drilling fluids.
- Describe the principle issues considered when programming a drilling fluid.
- List the various generic types of drilling fluid and the composition of these fluids.

Drilling Fluid Testing:

- Describe the equipment and procedures used to determine the: density; rheological properties; gel strength; filtration properties; sand content; liquids and solid content; pH; alkalinity; and CEC of a drilling fluid.

Water Based Muds:

- Describe the composition of water based muds.
- Define the terms: aggregation; dispersion; flocculation; and de-flocculation and describe the ways in which clays will end up in these conditions.
- Describe the additives used to increase/decrease the: viscosity; density and filtration of WBM.
- Describe the chemical formulation of inhibited WBM's.

Oil Based Muds:

- Describe the chemical formulation of oilbased muds.
- Describe the ways in which the: wettability; activity; viscosity and filtration of OBM can be measured..

Solids Control:

- Describe the principal mechanisms used in solids removal
- Describe the operation of: a shale shaker; a desander and desilter and; a centrifuge.
- Describe the configuration of solids control equipment for weighted and unweighted muds.

1. INTRODUCTION

Drilling fluid or **drilling mud** is a critical component in the rotary drilling process. Its primary functions are to remove the drilled cuttings from the borehole whilst drilling and to prevent fluids from flowing from the formations being drilled, into the borehole. It has however many other functions and these will be discussed below. Since it is such an integral part of the drilling process, many of the problems encountered during the drilling of a well can be directly, or indirectly, attributed to the drilling fluids and therefore these fluids must be carefully selected and/or designed to fulfil their role in the drilling process.

The cost of the mud can be as high as 10-15% of the total cost of the well. Although this may seem expensive, the consequences of not maintaining good mud properties may result in drilling problems which will take a great deal of time and therefore cost to resolve. In view of the high cost of not maintaining good mud properties an operating company will usually hire a service company to provide a drilling fluid specialist (**mud engineer**) on the rig to formulate, continuously monitor and, if necessary, treat the mud.

1.1 Functions and Properties of a Drilling Fluid

The primary functions of a drilling fluid are:

- Remove cuttings from the Wellbore
- Prevent Formation Fluids Flowing into the Wellbore
- Maintain Wellbore Stability
- Cool and Lubricate the Bit
- Transmit Hydraulic Horsepower to Bit

The drilling fluid must be selected and or designed so that the physical and chemical properties of the fluid allow these functions to be fulfilled. However, when selecting the fluid, consideration must also be given to:

- The environmental impact of using the fluid
- The cost of the fluid
- The impact of the fluid on production from the pay zone

The main functions of drilling fluid and the properties which are associated with fulfilling these functions are summarised in Table 1, and discussed below.



Function	Physical/Chemical Property
Transport cuttings from the Wellbore	Yield Point, Apparent Viscosity, Velocity, Gel Strength
Prevent Formation Fluids Flowing into the Wellbore	Density
Maintain Wellbore Stability	Density, Reactivity with Clay
Cool and Lubricate the Bit	Density, velocity,
Transmit Hydraulic Horsepower to Bit	Velocity, Density, Viscosity

Table 1 Function and Physical Properties of Drilling Fluid

a. Remove cuttings from the Wellbore

The primary function of drilling fluid is to ensure that the rock cuttings generated by the drillbit are continuously removed from the wellbore. If these cuttings are not removed from the bit face the drilling efficiency will decrease. If these cuttings are not transported up the annulus between the drillstring and wellbore efficiently the drillstring will become stuck in the wellbore. The mud must be designed such that it can:

- Carry the cuttings to surface while circulating
- Suspend the cuttings while not circulating
- Drop the cuttings out of suspension at surface.

The rheological properties of the mud must be carefully engineered to fulfil these requirements. The carrying capacity of the mud depends on the annular velocity, density and viscosity of the mud. The ability to suspend the cuttings depends on the gelling (**thixotropic**) properties of the mud. This gel forms when circulation is stopped and the mud is static. The drilled solids are removed from the mud at surface by mechanical devices such as **shale shakers, desanders and desilters** (see Section 5 below). It is not economically feasible to remove all the drilled solids before re-circulating the mud. However, if the drilled solids are not removed the mud may require a lot of chemical treatment and dilution to control the rheological properties of the mud. For a thorough treatment of the rheology of drilling fluids refer to the chapter on **DRILLING HYDRAULICS**.

b. Prevent Formation Fluids Flowing into the Wellbore

The hydrostatic pressure exerted by the mud column must be high enough to prevent an influx of formation fluids into the wellbore. However, the pressure in the wellbore must not be too high or it may cause the formation to fracture and this will result in the loss of expensive mud into the formation. The flow of mud into the formation whilst drilling is known as **lost circulation**. This is because a certain proportion of the mud is not returning to surface but flowing into the formation.

The pressure in the wellbore will be equal to:

$$P = 0.052 \times MW \times TVD$$

where,

P = hydrostatic pressure (psi)

MW = mud density of the mud or **mud weight** (ppg)

TVD = true vertical depth of point of interest = vertical height of mud column (ft)

The density of the mud may be expressed in either of the following units:

To obtain the following Units of density multiply the Units in the first colom by:

	S.G.	psi/ft	ppg
S.G.	1.0	0.433	8.33
psi/ft	2.31	1.0	19.23
ppg	0.12	0.052	1.0

Table 2 Conversion of Commonly used Units of Density

Example:

A mudweight of 12 **ppg** is equivalent to a mudweight of $12 \times 0.052 = 0.624$ **psi/ft**

A mudweight of 1.4 **S.G.** is equivalent to a mudweight of $1.4 \times 0.433 = 0.606$ **psi/ft**

The mud weight must be selected so that it exceeds the pore pressures but does not exceed the fracture pressures of the formations being penetrated. **Barite**, and in some cases **Haemitite**, is added to viscosified mud as a weighting material. These minerals are used because of their high density:

Mineral	Density (S.G.)
Silica (Sand)	2.5
Ca CO ₃	2.5
Barite	4.2
Haemitite	5.6

The relatively high density of Barite and Haemitite means that a much lower volume of these minerals needs to be added to the mud to increase the overall density of the mud. This will mean that the impact of this weighting material on the rheological properties of the mud will be minimised.

When drilling through permeable formations (e.g. sand) the mud will seep into the formation. This is not the same as the large losses of fluid which occurs in fractured formations, discussed above. As the fluid seeps into the formation a **filter cake** will be deposited on the wall of the borehole. Some fluid will however continue to filter through the filter cake into the formation. The mud and the filtrate can damage the productive formations in a number of ways. The loss of mud can result



in the deposition of solid particles or hydration of clays in the pore space. The loss of filtrate can also result in the hydration of clays. This will result in a reduction in the permeability of the formation. In addition to damaging the productivity of the formations the filter cake can become so thick it may cause stuck pipe. The ideal filter cake is therefore thin and impermeable.

c. Maintain Wellbore Stability

Data from adjacent wells will be useful in predicting borehole stability problems that can occur in troublesome formations (eg unstable shales, highly permeable zones, lost circulation, overpressured zones)

Shale instability is one of the most common problems in drilling operations. This instability may be caused by either one or both of the following two mechanisms:

- the pressure differential between the bottomhole pressure in the borehole and the pore pressures in the shales and/or,
- hydration of the clay within the shale by mud filtrate containing water.

The instability caused by the pressure differential between the borehole and the pore pressure can be overcome by increasing the mudweight. The **hydration** of the clays can only be overcome by using non water-based muds, or partially addressed by treating the mud with chemicals which will reduce the ability of the water in the mud to hydrate the clays in the formation. These muds are known as **inhibited muds**.

d. Cool and Lubricate the Bit

The rock cutting process will, in particular with PDC bits, generate a great deal of heat at the bit. Unless the bit is cooled, it will overheat and quickly wear out. The circulation of the drilling fluid will cool the bit down and help lubricate the cutting process.

e. Transmit Hydraulic Horsepower to Bit

As fluid is circulated through the drillstring, across the bit and up the annulus of the wellbore the power of the mud pumps will be expended in frictional pressure losses. The efficiency of the drilling process can be significantly enhanced if approximately 65% of this power is expended at the bit. The pressure losses in the system are a function of the geometry of the system and the mud properties such as viscosity, yield point and mud weight. The distribution of these pressure losses can be controlled by altering the size of the nozzles in the bit and the flowrate through the system. This optimisation process is discussed at length in the chapter on Drilling Hydraulics.

It is possible that in order to meet all of these requirements, and drill the well as efficiently as possible, more than one type of mud is used (e.g. water-based mud may be used down to the 13 3/8" casing shoe, and then replaced by an oil-based mud to drill the producing formation).

Some mud properties are difficult to predict in advance, so the mud programme has to be flexible to allow alterations and adjustments to be made as the hole is being drilled, (e.g. unexpected hole problems may cause the pH to be increased, or the viscosity to be reduced, at a certain point).

1.2 Types of Drilling Fluid

The two most common types of drilling fluid used are water based mud and oil based mud. These muds will be discussed in detail in Section 3 and 4 below but as a general statement, **Water-based muds (WBM)** are those drilling fluids in which the continuous phase of the system is water (salt water or fresh water) and **Oil-based muds (OBM)** are those in which the continuous phase is oil. WBM's are the most commonly used muds world-wide. However, drilling fluids may be broadly classified as liquids or gases (Figure 1). Although pure gas or gas-liquid mixtures are used they are not as common as the liquid based systems. The use of air as a drilling fluid is limited to areas where formations are competent and impermeable (e.g. West Virginia). The advantages of drilling with air in the circulating system are: higher penetration rates; better hole cleaning; and less formation damage. However, there are also two important disadvantages: air cannot support the sides of the borehole and air cannot exert enough pressure to prevent formation fluids entering the borehole. Gas-liquid mixtures (**foam**) are most often used where the formation pressures are so low that massive losses occur when even water is used as the drilling fluid. This can occur in mature fields where depletion of reservoir fluids has resulted in low pore pressure.

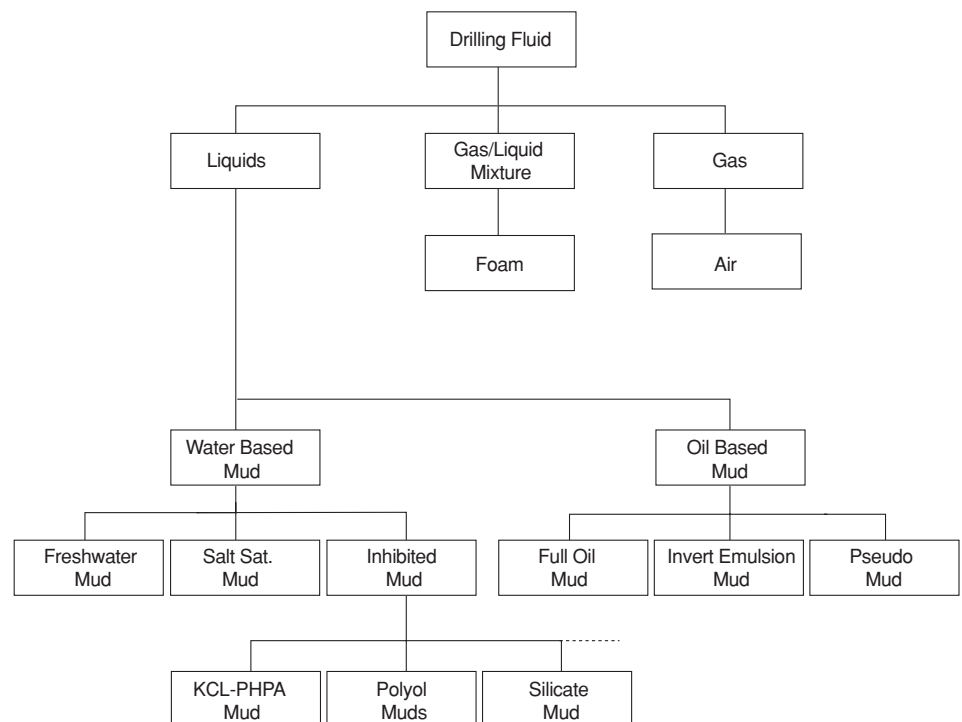

Figure 1 Types of Drilling Fluid

Water based muds are relatively inexpensive because of the ready supply of the fluid from which they are made - water. Water-based muds consist of a mixture of solids, liquids and chemicals. Some solids (clays) react with the water and chemicals in the mud and are called **active solids**. The activity of these solids must be controlled in order to allow the mud to function properly. The solids which do not react within the mud are called **inactive or inert solids** (e.g. Barite). The other inactive solids are generated by the drilling process. Fresh water is used as the base for most of these muds, but in offshore drilling operations salt water is more readily available. Figure 2 shows the typical composition of a water-based mud.

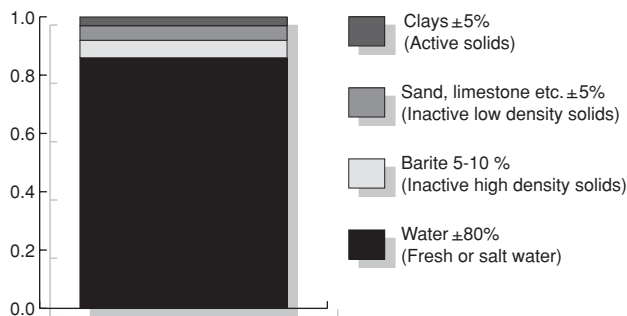

Figure 2 Composition of typical water -based mud

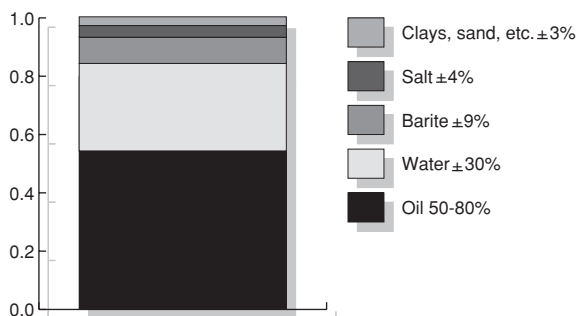

Figure 3 Composition of typical oil-based mud

The main disadvantage of using water based muds is that the water in these muds causes instability in shales. Shale is composed primarily of clays and instability is largely caused by hydration of the clays by mud containing water. Shales are the most common rock types encountered while drilling for oil and gas and give rise to more problems per meter drilled than any other type of formation. Estimates of worldwide, nonproductive costs associated with shale problems are put at \$500 to \$600 million annually (1997). In addition, the inferior wellbore quality often encountered in shales may make logging and completion operations difficult or impossible.

Over the years, ways have been sought to limit (or **inhibit**) interaction between WBMs and water-sensitive formations. So, for example the late 1960s, studies of mud-shale reactions resulted in the introduction of a WBM that combines potassium chloride (KCl) with a polymer called partially-hydrolyzed polyacrylamide – KCI-

PHPA mud. PHPA helps stabilize shale by coating it with a protective layer of polymer. The role of KCI will be discussed later.

The introduction of KCI-PHPA mud reduced the frequency and severity of shale instability problems so that deviated wells in highly water-reactive formations could be drilled, although still at a high cost and with considerable difficulty. Since then, there have been numerous variations on this theme, as well as other types of WBM aimed at inhibiting shale.

In the 1970s, the industry turned increasingly towards **oil-based mud, OBM** as a means of controlling reactive shales. Oil-based muds are similar in composition to water-based except that the continuous phase is oil. In an **invert oil emulsion mud (IOEM)** water may make up a large percentage of the volume, but oil is still the continuous phase. (The water is dispersed throughout the system as droplets). Figure 3 shows the typical composition of OBM's.

OBM's do not contain free water that can react with the clays in the shale. OBM not only provides excellent wellbore stability but also good lubrication, temperature stability, a reduced risk of differential sticking and low formation damage potential. Oil-based muds therefore result in fewer drilling problems and cause less formation damage than WBM's and they are therefore very popular in certain areas. Oil muds are however more expensive and require more careful handling (pollution control) than WBM's. Full-oil muds have a very low water content (<5%) whereas invert oil emulsion muds (IOEM's) may have anywhere between 5% and 50% water content.

The use of OBM would probably have continued to expand through the late 1980s and into the 1990s but for the realization that, even with low-toxicity mineral base-oil, the disposal of drilled cuttings contaminated by OBM can have a lasting environmental impact. In many areas this awareness led to legislation prohibiting or limiting the discharge of these wastes. This, in turn, has stimulated intense activity to find environmentally acceptable alternatives and has boosted WBM research.

To develop alternative nontoxic muds that match the performance of OBM requires an understanding of the reactions that occur between complex, often poorly characterized mud systems and equally complex, highly variable shale formations.

In recent years the base oil in OBMs has been replaced by **synthetic fluids** such as **esters and ethers**. Oil based muds do contain some water but this water is in a discontinuous form and is distributed as discrete entities throughout the continuous phase. The water is therefore not free to react with clays in Shale or in the productive formations.

2. FIELD TESTS ON DRILLING FLUIDS

The properties of drilling mud are regularly measured by the mud engineer. These measurements will be used to determine if the quality of the mud has deteriorated and requires treatment. The properties required to fulfil the tasks discussed in the earlier part of the chapter will be specified by the drilling engineer before the drilling operation commences but these properties may be adjusted if for instance

it is found that the drilled cuttings are not being removed efficiently or if losses are experienced.

A summary of the tests common to both water based and oil-based muds is given below :

2.1 Mud Density

The density of the drilling mud can be determined with the mud balance shown in Figure 4. The cup of the balance is completely filled with a sample of the mud and the lid placed firmly on top (some mud should escape through the hole in the lid). The balance arm is placed on the base and the rider adjusted until the arm is level. The density can be read directly off the graduated scale at the left-hand side of the rider.

Mud densities are usually reported to the nearest 0.1 ppg (lbs per gallon). Other units in common use are lbs/ft³, psi/ft, psi/1000ft, kg/l and specific gravity (S.G.).

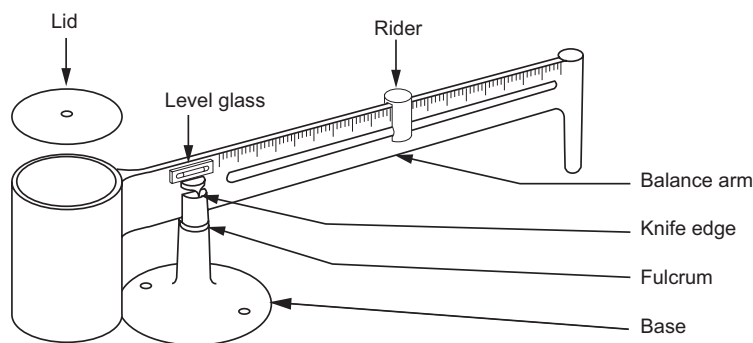

Figure 4 Mud balance

2.2 Viscosity

The rheological character of drilling fluids is discussed at length in the chapter on **DRILLING HYDRAULICS**. In general terms however, viscosity is a measure of a liquids resistance to flow. Two common methods are used on the rig to measure viscosity:

Marsh funnel (Figure 5): The Marsh Funnel shown in Figure 5 is used to make a very quick test of the viscosity of the drilling mud. However, this device only gives an indication of changes in viscosity and cannot be used to quantify the rheological properties of the mud, such as the Yield Point or Plastic Viscosity.

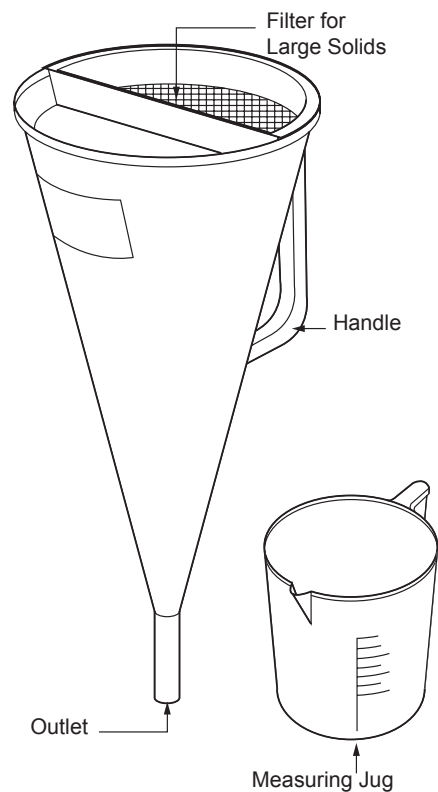

Figure 5 Marsh funnel and graduated cup

The standard funnel is 12" long, has a 6" diameter at the top and a 2" long, 3 /16" diameter tube at the bottom. A mud sample is poured into the funnel and the time taken for one quart (946 ml) to flow out into a measuring cup is recorded. (Fresh water at 75oF has a funnel viscosity of 26 sec/quart.)

Non-newtonian fluids (i.e. most drilling fluids) exhibit different viscosities at different flow rates and since the flow rate of the mud varies throughout this test it cannot provide a quantitative assessment of the rheological properties of the mud. The funnel viscosity can only be used for checking radical changes in mud viscosity. Further tests must be carried out before any treatment can be recommended.

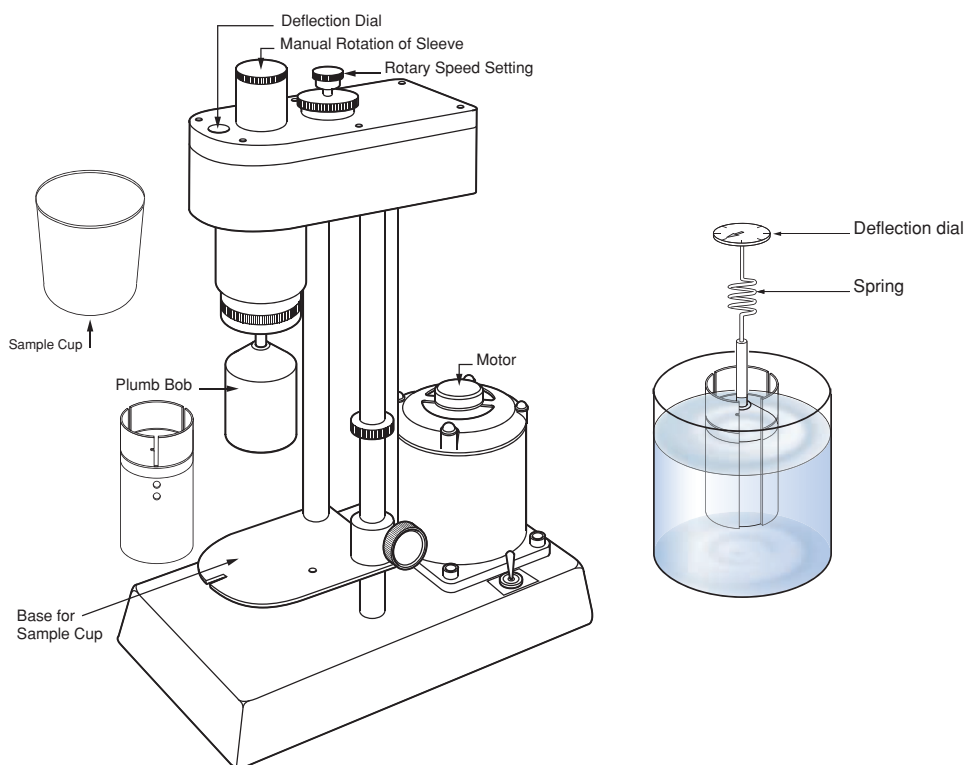

Figure 6 Multi-rate viscometer

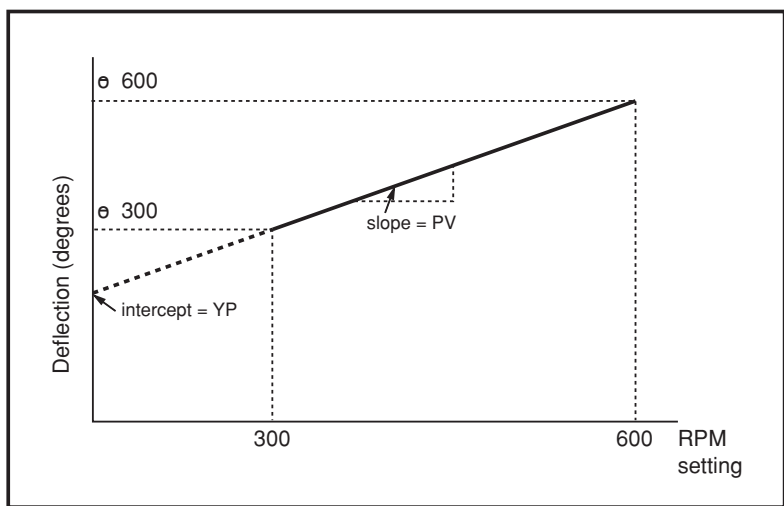

Figure 7 Typical graph drawn from viscometer results

Rotational viscometer (Figure 6): The multi-rate rotational viscometer is used to quantify the rheological properties of the drilling mud. The assessment is made by shearing a sample of the mud, at a series of prescribed rates and measuring the shear stress on the fluid at these different rates. The essential elements of the

device (Figure 7) are a plumb bob attached to a torsion spring and deflection gauge and a cylinder which can be rotated at a range of rotary speeds. The plumb bob is suspended inside the cylinder and the whole is immersed in a sample of the drilling mud. When the outer cylinder is rotated the mud between the cylinder and plumb bob is sheared. The deflection of the plumb bob is a measure of the viscosity of the drilling fluid at that particular shear rate. The shear rate and deflection can be plotted as shown in Figure 8.

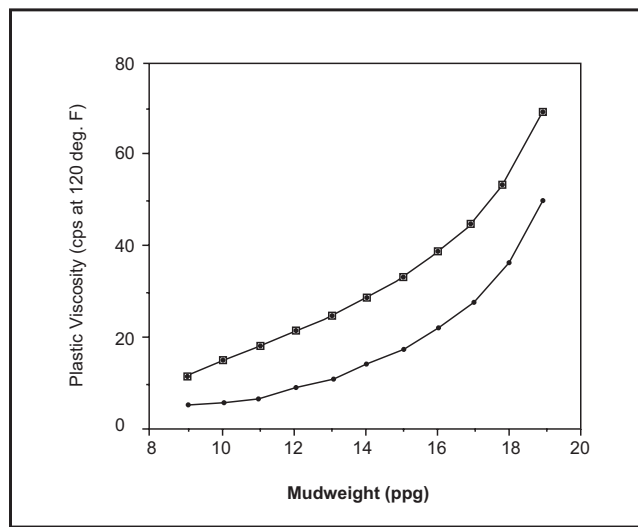

Figure 8 Acceptable range of PV for a given Mudweight

The test is conducted at a range of different speeds: 600 rpm; 300 rpm; 200 rpm; 100 rpm; 6 rpm and 3 rpm. The standard procedure is to lower the instrument head into the mud sample until the sleeve is immersed up to a scribe line. The rotor speed is set at 600 rpm and after waiting for a steady dial reading this value is recorded (degrees). The speed is changed to 300 rpm and again the reading is recorded. This is repeated until all of the required dial readings have been recorded. The results are plotted as shown in Figure 8. If there is a linear relationship between shear stress and shear rate (i.e. Bingham plastic) the following parameters can be calculated from the graph:

$$\text{Plastic Viscosity (PV)} = D600 - D300 \text{ (centipoise)}$$

$$\text{Yield Point (YP)} = D300 - PV \text{ (lb/100 ft}^2\text{)}$$

2.3 Gel Strength

The **gel strength** of the drilling mud can be thought of as the strength of any internal structures which are formed in the mud when it is static. These structures are discussed in the section of water based muds in section 3 below. The gel strength of the mud will provide an indication of the pressure required to initiate flow after the mud has been static for some time. The gel strength of the mud also provides an indication of the suspension properties of the mud and hence its ability to suspend cuttings when the mud is stationary.

The gel strength can be measured using the multi-rate viscometer. After the mud has remained static for some time (10 secs) the rotor is set at a low speed (3 rpm) and the deflection noted. This is reported as the **initial or 10 second gel**. The same procedure is repeated after the mud remains static for 10 minutes, to determine the **10 minute gel**. Both gels are measured in the same units as Yield Point (lbs/100ft²). Gel strength usually appears on the mud report as two figures (e.g. 17/25). The first being the initial gel and the second the 10 minute gel.

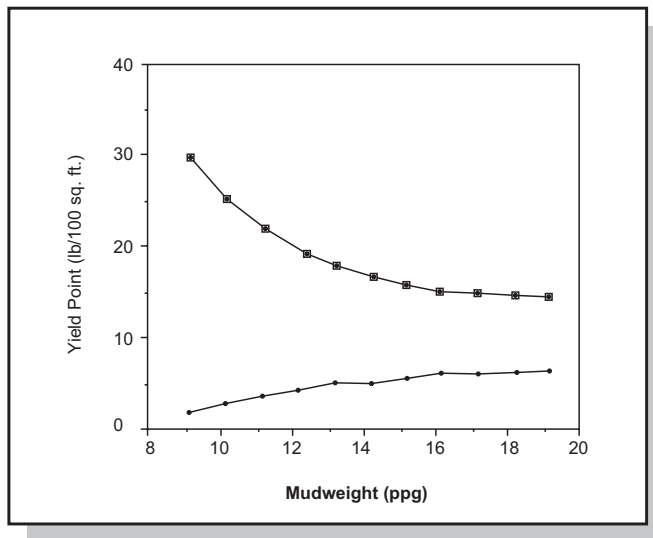

Figure 9 Acceptable range of YP for a given Mudweight

2.4 Filtration

The filter cake building properties of mud can be measured by means of a filter press (Figure 10). The following are measured during this test:

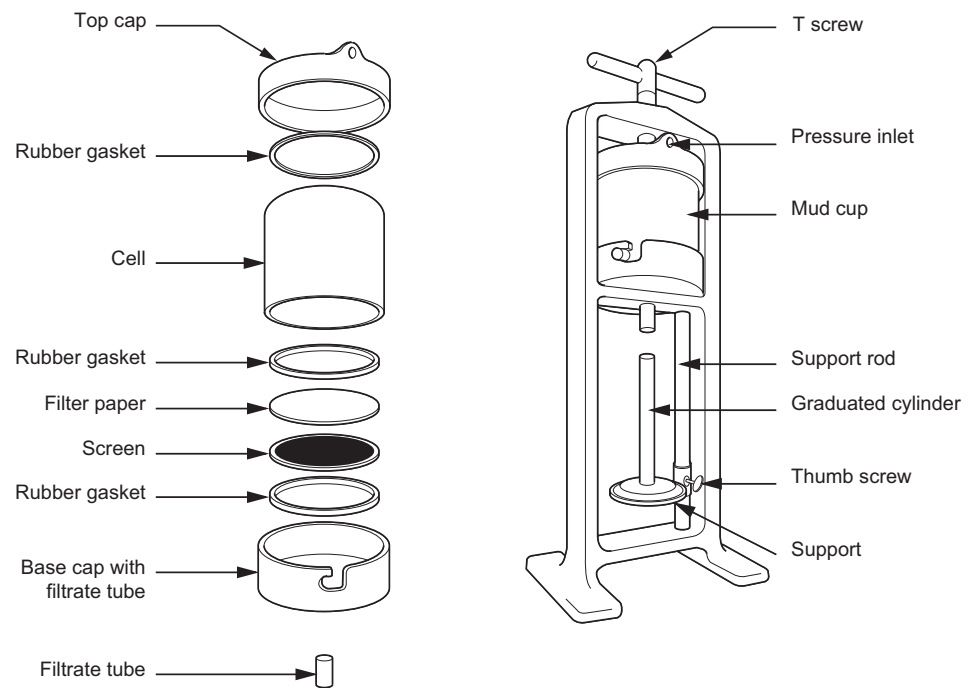

Figure 10 Filter press apparatus

- The rate at which fluid from a mud sample is forced through a filter under specified temperature and pressure.
- The thickness of the solid residue deposited on the filter paper caused by the loss of fluids.

The first of the above reflects the efficiency with which the solids in the mud are creating an impermeable filter cake and the second the thickness of the filter cake that will be created in the wellbore. Notice that this type of test does not accurately simulate downhole conditions in that only static filtration is being measured. In the wellbore, filtration is occurring under dynamic conditions with the mud flowing past the wall of the hole.

The instrument shown in Figure 10 consists of a mud cell, pressure assembly and filtering device. The API standard test is at room temperature and 100 psi pressure. A special cell must be used to conduct the test at high pressure and temperature (500 psi, 300 degrees F). The cell is closed at the bottom by a lid which is fitted with a screen. On top of the screen is placed a filter paper which is pressed up against an O-ring seal. A graduated cylinder is placed under the screen to collect the filtrate. The pressure of 100 psi is applied for a period of 30 minutes and the volume of filtrate can then be measured (in cm³). When the pressure is bled off the cell can be opened and the filter paper examined. The thickness of the filter cake is measured in 1/32's of an inch.

2.5 Sand Content

A high proportion of sand in the mud can damage the mud pumps and is therefore undesirable. The percentage of sand in the mud is therefore measured regularly using a 200 mesh sieve and a graduated tube (Figure 11). The glass measuring tube is filled with mud up to the scribe line. Water is then added up to the next scribe line. The fluids are mixed by shaking and then poured through the sieve. The sand retained on the sieve should be washed thoroughly to remove any remaining mud. A funnel is fitted to the top of the sieve and the sand is washed into the glass tube by a fine spray of water. After allowing the sand to settle the sand content can be read off directly as a percentage.

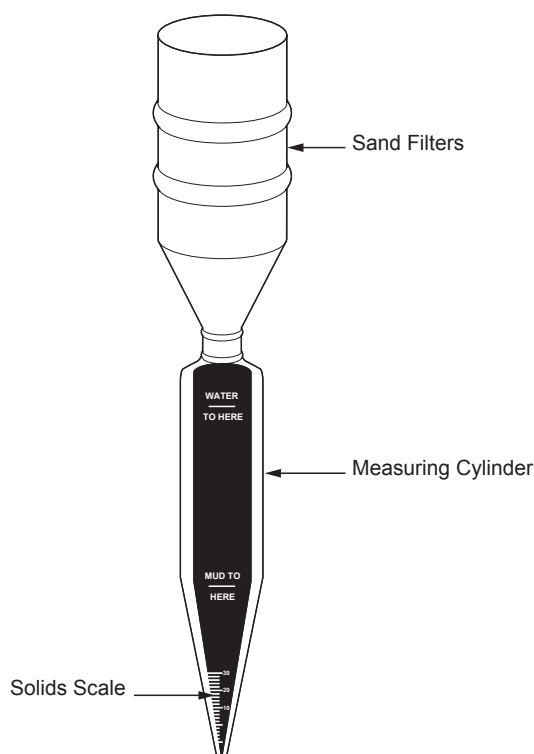

Figure 11 Sand Content Apparatus

2.6 Liquid and Solid Content

If pipe sticking is to be avoided, the proportion of solids in the mud should not exceed 10% by volume. A carefully measured sample of mud is heated in a retort until the liquid components are vaporised. The vapours are then condensed, and collected in the measuring glass. The volume of liquids (oil and/or water) is read off directly as a percentage. The volume of solids (suspended and dissolved) is found by subtraction from 100%.

2.7 pH Determination

The pH of the mud will influence the reaction of various chemicals and must therefore be closely controlled. The pH test is a measure of the concentration of hydrogen ions in an aqueous solution. This can be done either by pH paper or by a special pH meter. The pH paper will turn different colours depending on the

concentration of hydrogen ions. A standard colour chart can be used to read off the pH to the nearest 0.5 of a unit (on a scale of 0 to 14). With a pH meter the probe is simply placed in the mud sample and the reading taken after the needle stabilises (make sure probe is washed clean before use). The meter gives a more accurate result to 0.1 of a unit.

2.8 Alkalinity

Although pH gives an indication of alkalinity it has been characteristics of a high pH mud can vary considerably despite constant pH. A further analysis of the mud is usually carried out to assess the alkalinity. The procedure involves taking a small sample, adding phenolphthalein indicator and titrating with acid until the colour changes. The number of ml of acid required per ml of sample is reported as the alkalinity. (Pf = filtrate alkalinity, Pm = mud alkalinity). Another parameter related to Pf and Pm is lime content. This can be calculated from:

$$\text{lime content} = 0.26 (P_m - F_w P_f)$$

where,

lime content is in lb/bbl

F_w = volume fraction of water in the mud.

2.9 Chloride Content

The amount of chloride in the mud is a measure of the salt contamination from the formation. The procedure for measuring the quantity of salt in the mud is to take a small sample of filtrate of the mud, adding phenolphthalein and titrating with acid until the colour changes. 25 - 50 ml of distilled water and a small amount of potassium chromate solution is then added. The solution is stirred continuously while silver nitrate is added drop by drop. The end point is reached when the colour changes. The chloride content is calculated from:

$$\text{Cl content (ppm)} = \frac{\text{ml of silver nitrate} \times 1000}{\text{ml of filtrate sample}}$$

2.10 Cation Exchange Capacity

This test gives an approximate measure of the bentonite (sodium montmorillonite) content of the mud. The sodium cation (Na⁺) of bentonite is held loosely on the clay structure and is readily exchanged for other ions and certain organic compounds. Methylene blue is an organic dye which will replace the exchangeable cations in montmorillonite and certain other mud additives (eg organic compounds such as CMC, lignite). A small mud sample is put in a flask where it is first treated with hydrogen peroxide to remove most of the organic content. Methylene blue solution is added in increments of 0.5 ml. After each increment the flask is well shaken, and while the solids are still suspended one drop is placed on filter paper. The end point is reached when the dye appears as a greenish-blue ring around the solids on the filter paper.

$$\text{The methylene blue capacity} = \frac{\text{ml of methylene blue}}{\text{ml of mud sample}}$$



The bentonite content (lb/bbl) = 5 x methylene blue capacity. The cation exchange capacity of other solids can be done in a similar way. The capacity can be expressed in milliequivalents of methylene blue per 100 g of solids (Table 1). Note the high reading for montmorillonite clay compared with other clays.

3. WATER BASED MUD

Water itself may be used as a drilling fluid. However, most drilling fluids require some degree of viscosity to suspend the Barites and to carry drilled cuttings up the annulus of the wellbore. The viscosity of water based muds is generated by the addition of clay or polymers. However the cheapest and most widely used additive for viscosity control is clay. The clay material in water based mud is responsible for two beneficial effects:

- An increase in viscosity which improves the lifting capacity of the mud to carry cuttings to the surface. (This is especially helpful in larger holes where annular velocity is low).
- Building a wall cake in permeable zones, thus preventing fluid loss.

The clays are not the only solids in a drilling fluid. There are two types of solids which may be present in a water based mud:

- Active solid - these are solids which will react with water and can be controlled by chemical treatment. These may be commercial clays or hydratable clays from the formations being drilled.
- Inactive or inert solids - these are solids which do not readily react with water. These may be drill solids such as limestone or sand. Barite is also an inert solid.

In order to appreciate how clays play an important part in water based muds some understanding of clay chemistry is necessary.

3.1 Clay Chemistry (See Appendix 1)

Clay minerals can be divided into two broad groups.

- Expandable (hydrophillic) clays - these will readily absorb water (e.g. montmorillonite).
- Non-expandable (hydrophobic) clays - these will not readily absorb water (e.g. illite).

Clay minerals have a sandwich-like structure usually consisting of three layers. The alternate layers are of silica and alumina. A clay particle usually consists of several sandwiches stacked together like a pack of cards.

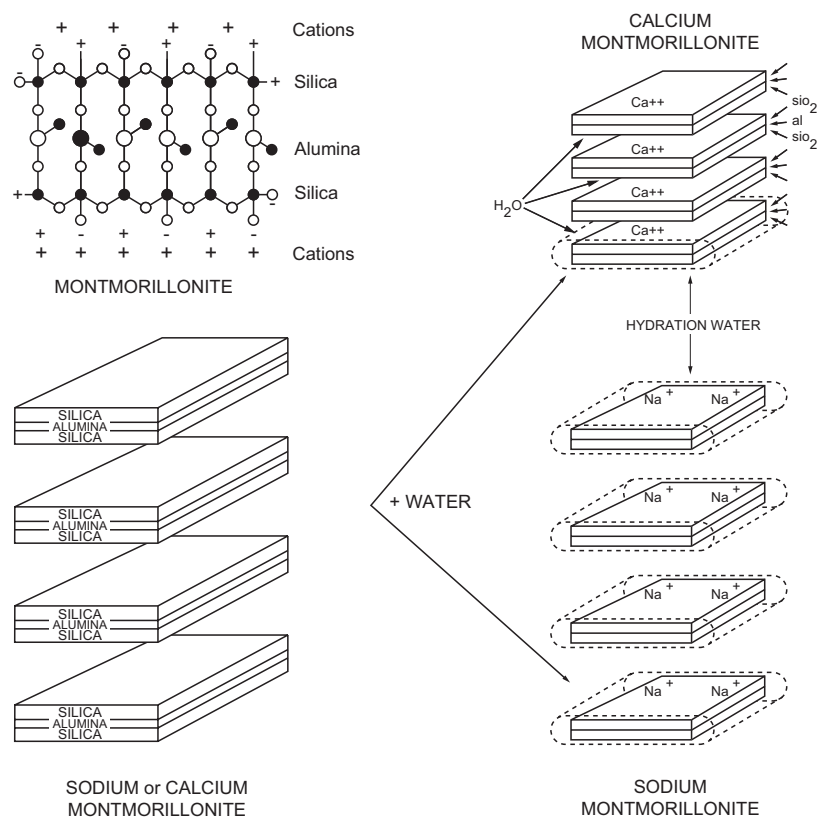

Figure 12 Hydration of Montmorillonite

Expandable and Non-expandable clays in water

The most commonly clay used in drilling fluids is Wyoming Bentonite (sodium montmorillonite). Figure 12 shows a simplified diagram of its structure. In fresh water the clay layers absorb water, the chemical bonds holding them together are weakened and the stack of layers disintegrates. This process is known as **dispersion** (i.e. less face-to-face association). Dispersion results in an increase in the number of particles in suspension, which in turn increases the number of suspended particles and causes the fluid to thicken or viscosify. During this process, positively charged cations separate from the clay surface leaving the flat surface of the particles negatively charged while the edges are positively charged. It is likely therefore that some plates will tend to form edge-to-face arrangements. This process is known as **flocculation**.

In a Bingham Plastic fluid, Plastic viscosity can be thought of as that part of the flow resistance caused by mechanical friction between the particles present in the mud and will therefore be dependant on solids content. Yield point is that component of resistance caused by electro-chemical attraction within the mud while it is flowing.

There are 4 arrangements of clay particles which are commonly encountered (Figure 13):

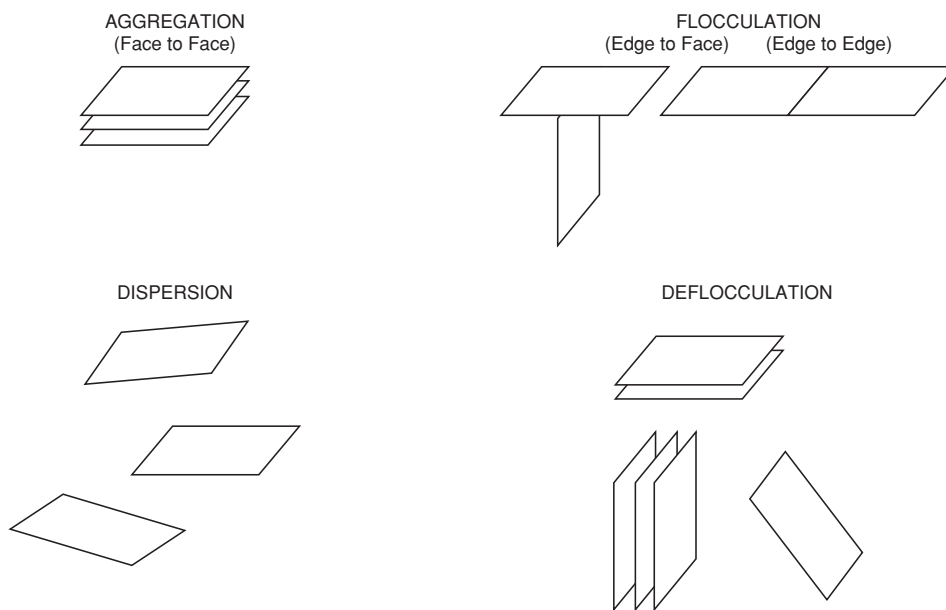

Figure 13 Association of clay particles

Aggregation (Face-to-face) is the natural state for the clay particles. In this configuration there are a small number of particles in suspension and therefore the plastic viscosity of the mud is low. If the mud has, at some time been dispersed, aggregation may be achieved by introducing cations (e.g. Ca^{2+}) to bring the plates together. Lime or gypsum may be added to achieve this effect.

Dispersion occurs when the individual clay platelets are dispersed by some mechanism. Dispersion increases the number of particles and causes an increase in plastic viscosity. Clays will naturally disperse in the presence of freshwater but this process will be enhanced by agitation of the mud. Bentonite does not usually completely disperse in water.

Flocculation is when a house of cards structure is formed because of the attraction between the positive charges on the face of the particles and the negative charges on the edge of the particles. Flocculation increases the viscosity and yield point of the mud. The severity of flocculation depends on the proximity of the charges acting on the linked particles. Anything that shrinks the absorbed water film around the particles (e.g. temperature) will decrease the distance between the charges on the particles and increase flocculation.

De-flocculation occurs when the house of cards structure is broken down and something is introduced into the mud that reduces the edge-to-face effect. Chemicals called “thinners” are added to the mud to achieve this.

3.2 Additives to WBM’s

a. Viscosity control additives

Commercial clays are used to control the viscosity of water based muds. These are graded according to their **yield**. The yield of a clay is defined as the number

of barrels of 15 centipoise viscosity mud which can be obtained from 1 ton of dry clay. (A 15 centipoise viscosity will support barite). Wyoming bentonite has a yield of about 100 bbl/ton, whereas native clays may only yield 10 bbl/ton. The result of this would be that the native clay would cause a higher solids content and mud density than the Wyoming bentonite to build the same viscosity. The specifications for bentonite are laid down by the API and are shown in Table 4. The yield of a clay will be affected by the salt concentration in the mixwater. The hydration and therefore dispersion of the clay are greatly reduced by the presence of Ca²⁺ and Mg²⁺ ions. To overcome this problem various measures can be taken:

- Chemical treatment to reduce salt concentration by precipitation.
- Dilution with fresh water.
- Attapulgite clay may be used. Attapulgite has a different structure to montmorillonite and does not depend on the type of make up water to build viscosity. It is however more expensive and provides poor filtration control.
- first hydrate the clay in fresh water, then add the slurry to the salt water.
- use organic polymers (cellulose) to build viscosity.

Type of solid	meq/100g of solids
Attapulgite clay	15 - 25
Chlorite clay	10 - 40
Gumbo shale	20 - 40
Illite clay	10 - 40
Kaoline clay	3 - 15
Montmorillonite clay	80 - 150
Sandstone	0 - 5
Shale	0 - 20

Table 3 Methylene Blue Absorptive Capacity

600 rpm viscometer reading:	30 cp (min.)
YP:	3 x PV (min.)
Filtrate:	13.5 ml (max.)
Residue on No. 200 sieve:	2.5% (max.)
Moisture content:	10% (max.)
Yield:	91.8 bbls/ton

Table 4 API Specification for Bentonite



Specific gravity:	4.2 (min)
Soluble metals or calcium:	250 ppm (max)
Wet screen analysis	
Residue on No.	200 sieve: 3% (max)
Residue on No.	325 sieve: 5% (min)

Table 5 API Specification for Barite

To reduce the viscosity of the mud:

- Lower the solids content.
- Reduce the number of particles per unit volume.
- Neutralize attractive forces between the particles.

The use of screens, desilters and other mechanical devices will reduce viscosity, but chemical additives may also be used. These chemicals produce negatively charged anions in solution and thereby reduce the positive charge on the edge of the clay plates. This reduces the edge-to-face association and therefore reduces viscosity. Such chemicals are called thinners (or dispersants) and include: Phosphates; Lignites; Lignosulphonates; and Tannins.

b) Density control additives

Barite (barium sulphate, BaSO₄) is the primary weighting material used in muds. Densities of 9 ppg to 19 ppg can be achieved by mixing water, clay and barite. The API specification for barite is shown in Table 5. Other weighting materials are calcium carbonate and galena (lead sulphide). The drill solids from the formation will increase the mud density if they are not separated out. This will be discussed under solids control.

c) Filtration control additives

Loss of fluid from the mud occurs when the mud comes into contact with a permeable zone. If the pores are large enough the first effect will be a spurt loss, followed by the buildup of solids to form a mud cake. The rate at which fluid is lost is a function of the differential pressure, thickness of filter cake and viscosity of the filtrate. Excessive filtration rates and thick wall cake can lead to problems such as:

- Tight spots in the hole
- Differential pipe sticking
- Formation damage due to filtrate invasion

Since a filter cake attains its greatest thickness under static conditions the mud is tested under static conditions. Dynamic filtration results in a thinner mud cake due to erosion effects, but the rate of filtration will be higher. The aim is to deposit a thin and impermeable filter cake. Several types of material may be added to the mud to control fluid loss.

- Clays - Bentonite is an effective fluid loss control agent because of its particle size and shape, and also because it hydrates and compresses under pressure. The particle size distribution is such that most particles will be less than 1 micron.

Care should be taken not to remove these small particles by using a centrifuge for solids control.

- Starch - These organic chemicals will swell rapidly and seal off the permeable zones effectively.
- CMC - This is an organic colloid (sodium carboxyl-methyl cellulose). The long chain molecules can be polymerized into 3 different grades (high, medium and low viscosity). It is thought that CMC controls filtration by wedging long chain polymers into the formation and plugging the pores. CMC works well in most water-based muds, but less effective in high salt concentrations (>50,000 ppm).
- Polyacrylates (Cyan) - These are long chain polymers which become absorbed onto the edge of clay particles.
- Lignosulphonates - Similar in action to starch in reducing fluid loss.
- Polyanionic cellulose (Drispac) - An organic compound which is used to control fluid loss in high salt concentrations, and is often used in low solids mud. May also be used as a viscosifier.

The water loss allowable in any particular area will largely depend on experience. As the well is being drilled the fluid loss must be adjusted as new formations are penetrated. The surface hole may be drilled with a fluid loss of 20 cc, but across productive formations it will be reduced (down to possibly 5 cc). Control over fluid loss depends on the correct addition of chemicals and keeping the clay solids dispersed. Fluid loss control agents may also act as thinners, or viscosifiers under certain circumstances, and react unfavourably with other chemicals in the mud.

d) pH control additives

Caustic soda NaOH is the major additive used to keep the pH of the mud high. This is desirable to prevent corrosion and hydrogen embrittlement. The pH of most muds lies between 9.5 and 10.5. Caustic potash, KOH and slaked lime, Ca(OH)₂ may also be used.

e) Removal of contaminants

Various substances may enter the mud and cause an adverse effect on the quality of the mud and reduce its efficiency. These contaminants must be removed. The main contaminants are listed below:

- Calcium (Ca²⁺) - may enter from cement, gypsum, lime or saltwater. It reduces the viscosity building properties of bentonite. It is usually removed from fresh water muds by adding soda ash Na₂CO₃, which forms insoluble CaCO₃. If calcium is present in the mud the pH will normally be too high.
- Carbon dioxide (CO₂) - present in formations which when entrained in the mud can cause adverse filtration and gelation characteristics. To remove CO₂ calcium hydroxide can be added to precipitate CaCO₃.

- Hydrogen sulphide (H₂S) - present in formations. Highly toxic gas which also causes hydrogen embrittlement of steel pipe. Add NaOH to keep pH high and form sodium sulphide. If the pH is allowed to drop the sulphide reverts back to H₂S
- Oxygen (O₂) - entrained into mud in surface pits, causes corrosion and pitting of steel pipe. Sodium sulphite (Na₂SO₃) is added at surface to remove the Oxygen.

3.3 Special Types of Water Based Muds

3.3.1 Inhibited Muds:

The hydration of clays is severely reduced if the water used to make up the mud contains a high salt concentration. If a shale zone is being drilled with a freshwater mud the clays in the formation will tend to expand and the wellbore becomes unstable (sloughing shale). By using a mud containing salt or calcium there will be less tendency for this problem to occur. An inhibitive mud is defined as one where the ability of active clays to hydrate has been greatly reduced. Another advantage is that the water normally used in hydration is available to carry more solids. Inhibitive muds are principally used to drill shale and clay formations, and are characterised by:

- Low viscosity
- Low gel strength
- Greater solids tolerance
- Greater resistance to contaminants

a. Calcium treated muds

When Ca²⁺ ions are added to a clay-water mud the mud begins to thicken due to flocculation. At the same time a cation exchange reaction begins whereby Ca²⁺ replaces Na²⁺ on the clay plates. Calcium **montmorillonite** does not hydrate as extensively as sodium montmorillonite, and the plates begin to aggregate. As the reaction proceeds the mud begins to thin and viscosity reduces.

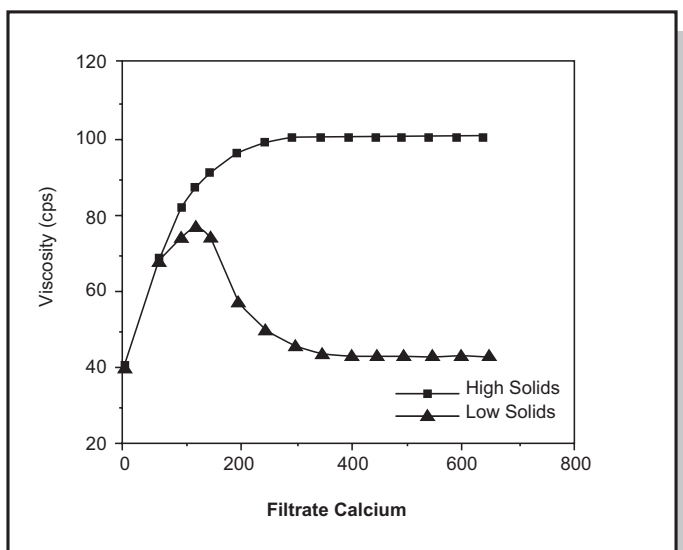

Figure 14 Effect of Calcium Treatment on Viscosity

The conversion of a fresh water mud to an inhibited mud usually takes place in the wellbore. The conversion should not be done at a shallow depth where large volumes of cuttings are being lifted, as this might cause a viscous plastic mass around the bit. Figure 14 shows how the viscosity varies during this conversion. Gypsum $\text{CaSO}_4 \cdot 2\text{H}_2\text{O}$ or calcium chloride CaCl_2 can be used in place of lime to supply the Ca^{2+} ions.

b. Lignosulphanate treated muds

An inhibited mud can also be formed by adding large amounts (12 lb/bbl) of lignosulphanate to a clay-water system. Chrome lignosulphanate is commonly used since it is relatively cheap and has a high tolerance for salt and calcium.

c. Saltwater muds

Inhibitive muds having a salt concentration (NaCl) in excess of 1% by weight are called salt water muds. These are often used in marine areas where fresh water is not readily available. As stated earlier commercial clays (e.g. bentonite) will not readily hydrate in water containing salt concentration (i.e. bentonite behaves like an inert solid). To build viscosity therefore the clay must be prehydrated in fresh water, then treated with deflocculant before increasing salinity. The Ca^{2+} and Mg^{2+} ions can be removed by adding NaOH to form insoluble precipitates which can be removed before building viscosity. After conversion salt water muds are not greatly affected by subsequent contamination. However the increased salt content may make it more difficult to maintain other mud properties. (Alkalinity is controlled by adding NaOH and filtration by adding bentonite). Corrosion may be a major problem in salt water muds unless alkalinity is controlled.

d. KCL - polymer system

This mud system was specifically developed to combat the problem of water sensitive, sloughing shales. The potassium chloride concentration must be at least 3 - 5% by weight to prevent swelling of shales containing illite and kaolinite. For shales containing bentonite the KCl concentration must be raised to 10%. Polyacrylamide polymers are used to control the viscosity of the mud and are used in concentrations of around 0.75 lb/bbl. Potassium hydroxide or caustic soda may be used to control the pH at around 10. This system allows good shale stabilisation, hole cleaning and flocculation of drilled solids. The KCl polymer system is stable up to 300 degrees F. Temperatures above 300 degrees F will cause slow degradation of the polymer.

e. Polyol muds

Polyol is the generic name for a wide class of chemicals – including glycerol, polyglycerol or glycols such as propylene glycol – that are usually used in conjunction with an encapsulating polymer (PHPA) and an inhibitive brine phase (KCl). These materials are nontoxic and pass the current environmental protocols, including those laid down in Norway, the UK, The Netherlands, Denmark and the USA.

Glycols in mud were proposed as lubricants and shale inhibitors as early as the 1960s. But it was not until the late 1980s that the materials became widely considered. Properly engineered polyol muds are robust, highly inhibitive and often cost-effective. Compared with other WBM systems, low volumes of additives are typically required. Polyols have a number of different effects, such as lubricating the drillstring, opposing bit balling (where clays adhere to the bit) and improving



fluid loss. Today, it is their shale-inhibiting properties that attract most attention. For example, tests carried out by BP show that the addition of 3 to 5% by volume of polyglycol to a KCl-PHPA mud dramatically improves shale stabilization. However, a significant gap still remains between the performance of polyol muds and that of OBM.

Field experience using polyol muds has shown improved wellbore stability and yielded cuttings that are harder and drier than those usually associated with WBM. This hardness reduces breakdown of cuttings and makes solids control more efficient. Therefore, mud dilution rates tend to be lower with polyol muds compared with other WBM systems (for an explanation of solids control and dilution, see mud management).

As yet, no complete explanation of how polyols inhibit shale reactivity has been advanced, but there are some clues:

- Most polyols function best in combination with a specific inhibitive salt, such as potassium, rather than nonspecific high salinity.
- Polyol is not depleted rapidly from the mud even when reactive shales are drilled.
- Many polyols work effectively at concentrations as low as 3%, which is too low to significantly change the water activity of the base fluid.
- Polyols that are insoluble in water are significantly less inhibitive than those that are fully soluble.
- No direct link exists between the performance of a polyol as a shale inhibitor and its ability to reduce fluid loss.

Many of these clues eliminate theories that try to explain how polyols inhibit shales. Perhaps the most likely hypothesis – although so far there is no direct experimental evidence supporting it – is that polyols act as a structure breaker, disrupting the ordering of water on the clay surface that would otherwise cause swelling and dispersion. This mechanism does not require the glycol to be strongly absorbed onto the shale, which is consistent with the low depletion rates seen in the field.

f. Mixed-metal hydroxide (MMH) mud

MMH mud has a low environmental impact and has been used extensively around the world in many situations: horizontal and short-radius wells, unconsolidated or depleted sandstone, high-temperature, unstable shales, and wells with severe lost circulation. Its principal benefit is excellent hole-cleaning properties.

Many new mud systems – including polyol muds – are extensions of existing fluids, with perhaps a few improved chemicals added. However, MMH mud is a complete departure from existing technology. It is based on an insoluble, inorganic, crystalline compound containing two or more metals in a hydroxide lattice – usually mixed aluminium/magnesium hydroxide, which is oxygen-deficient. When added to prehydrated bentonite, the positively charged MMH particles interact with the negatively charged clays forming a strong complex that behaves like an elastic solid when at rest. This gives the fluid its unusual rheology: an exceptionally low plastic viscosity-yield point ratio. Conventional muds with high gel strength usually require high energy to initiate circulation, generating pressure surges in the annulus once flow has been established. Although MMH has great gel strength at rest, the

structure is easily broken. So it can be transformed into a low-viscosity fluid that does not induce significant friction losses during circulation and gives good hole cleaning at low pump rates even in high-angle wells. Yet within microseconds of the pumps being turned off, high gel strength develops, preventing solids from settling.

There are some indications that MMH also provides chemical shale inhibition. This effect is difficult to demonstrate in the laboratory, but there is evidence that a static layer of mud forms adjacent to the rock face and helps prevent mechanical damage to the formation caused by fast-flowing mud and cuttings, controlling washouts.

MMH is a special fluid, sensitive to many traditional mud additives and some drilling contaminants. It therefore benefits from the careful management that is vital for all types of drilling fluid.

g. Silicate Fluids

Silicate is used as a shale hydration suppressor. The Sodium Silicate precipitates a layer of Silicate over the reactive sites on the clay particle and over microfractures in the matrix thus preventing hydration by water migration into the clay.

3.3.2 Brine Drilling Fluid

Polymers are added to brine to viscosify the water and provide some filtration control. Certain polymers (XC or Duovis) are of particular value since they possess low viscosity at high shear rate, and high viscosity at low shear rates. The effect of this is good flow properties in the drillstring (at high shear rate) combined with good lifting properties in the annulus (low shear rates). About 0.5 lb/bbl of XC polymer should be added. Drilled solids must be controlled by dilution and mechanical devices. Good performance is achieved using desanders and desilters.

4. OIL-BASED MUDS

An oil-based mud is one in which the base fluid from which the mud is made up is oil. Since the 1930's it has been recognised that better productivity is achieved from reservoirs when oil based fluids rather than water based fluids are used to drill through the reservoir. This is largely because the oil does not cause the clays in the reservoir to swell or cause changes in wettability of the formations. Crude oil was first used to drill through the pay zone, but it suffered from several disadvantages (low gel strength, limited viscosity, safety hazard due to low flash point). Modern oil-based muds use low-toxicity base oils and a variety of chemical additives to build good mud properties. The use of oil in the drilling fluid does have several disadvantages:

- Higher initial cost
- More stringent pollution controls required
- Reduced effectiveness of some logging tools (resistivity logs)
- Detection of kicks more difficult due to gas solubility in base oil

However for some applications oil-based muds are very cost effective. These include:



-
- To drill and core pay zones
 - To drill troublesome formations (e.g. shale, salt)
 - To add lubricity in directional drilling (preventing stuck pipe)
 - To reduce corrosion
 - As a completion fluid (during perforating and workovers)

There are three types of oil-based muds in common use:

- Full oil (water content < 5%)
- Invert oil emulsions (water content 5 - 50%)
- Synthetic or Pseudo oil based mud

The first oil base drilling fluid was crude oil, and was used to complete shallow, low pressure zones. Although there is no record of its first usage, it probably occurred soon after the advent of rotary drilling. The first patent application for an oil base drilling fluid was issued in 1923, but this fluid was not a commercial success.

Oil Base Drilling Fluids Company (now Hughes Drilling Fluids) was formed by George Miller to manufacture, market, and service the first commercial oil base drilling fluid, Black Magic. On May 1, 1942, Richfield Oil Company (now ARCO) used Black Magic as a completion fluid. Black Magic at that time was composed of air blown asphalt dispersed in a diesel oil which contained naturally occurring naphthenic acid, quick lime, and 5% by volume water. The uses of Black Magic in these early years were as completion fluids for low pressure and/or low permeability sands, coring fluids, and to free stuck pipe.

This original system performed well when applied properly. However, it had some obvious drawbacks. Asphalt was the primary viscosifier and fluid loss control additive. It did a good job of both but contributed to very high apparent and plastic viscosities and consequently was detrimental to drilling rates when compared to a water mud of the same density. It was also much more expensive per unit volume than water mud.

Because it did perform many functions well, the industry then set about to improve on it. From this work came the development of what are called the **Inverts or Invert Emulsion Muds**. Invert emulsion means that water is emulsified in oil (water-in-oil emulsion). In the earlier years (1940's), one of the most popular water muds run was oil-in-water. These muds were called oil emulsion systems. Therefore, during the development of invert emulsion systems, the term "inverts" or invert emulsion was used to differentiate the oil system containing some oil.

The control of the water base muds is made possible because of the wide variety of additives available for performing specific functions. At this time in history, development of oil mud additives and the technology of oil muds were pointed in the same direction. The first step dealt with the amount of water emulsified. Inverts were developed to contain and tolerate a much greater water volume than true oil muds. Rheology could then be controlled by altering oil/water ratios. This allowed the system to have adequate weight material suspension and filtration control with lower viscosity and gels. Water contamination became a less acute problem with inverts. Oil/water ratios ranged from 55/45 to 70/30.

The initial preparation of many oil muds tended to be time consuming and expensive because additives such as asphalt did not blend readily in crude or diesel oils but required heat for adequate dispersion. Muds containing these additives had to be prepared at a mixing plant and hauled to the rig site. Make up costs were also high with true oil mud due to higher volume percentage of oil plus the large additions of asphalt.

Water contamination was an acute problem causing excessive viscosity and water-wetting of solids, necessitating replacement of the system or at least dilution with new mud. Water contamination of invert emulsions required adjustment of mud properties by the addition of oil and emulsifiers. The principal components in the oil muds could not be added to adjust a single property without affecting most of the other mud properties. Single additives to adjust or control specific mud properties were not available at the time to provide the flexibility and versatility needed for lower cost.

The original inverts were composed of the same basic ingredients as the true oil muds. The concentrations of materials differed however. Calcium and magnesium soaps were used along with asphalt in small concentrations. Sodium chloride brine was used as the internal phase. The earliest of these systems, No-Blok (Magcobar) and Kenex (Ken Corp., later IMC) did not have any other additives. Although they were more flexible (rheologically) than the true oil mud, they were not as stable.

In recent years the base oil in OBMs has been replaced by **synthetic fluids** such as **esters and ethers**. These fluids are generally called **synthetic or pseudo oil based muds**.

4.1 Water in oil emulsions

The water in invert emulsion muds is dispersed as small droplets throughout the oil. Emulsifiers coat the droplets, preventing them from coalescing and making the mud unstable (i.e. larger water droplets will settle out and break down the emulsion). A calcium or magnesium fatty acid soap is often used as an emulsifier in an oil-based mud. The long hydrocarbon chain of the soap molecule tends to be soluble in oil while the ionic portion tends to be soluble in water. When soap is added to a mixture of oil and water the molecule takes up the position shown in Figure 15.

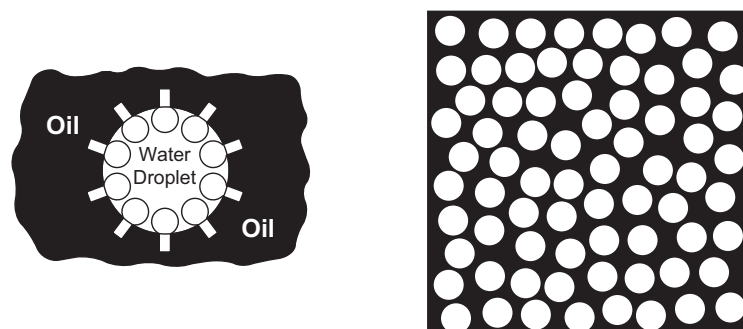

Figure 15 Water droplets dispersed in a continuous oil phase.



This reduces the surface energy of the interface and keeps the water droplets in the emulsion. Other types of emulsifiers can also be used (e.g. naphthenic acid soaps and soaps from tree sap). The effectiveness of an emulsifier depends on the alkalinity and electrolytes present in the water phase and also on the temperature of the mud. To increase the stability the water droplets should be as small and uniform as possible. This is done by shearing the mud by agitators. When oil is added the stability increases, since the distance between droplets becomes greater. This causes a decrease in viscosity. For good mud properties there must be a balance between oil and water. The water droplets help to:

- Support the barite
- Reduce filter loss
- Build viscosity and gel strength

4.2 Wettability control

When a drop of liquid is placed on a solid it will either:

- Spread itself over the surface of the solidor
- Remain as a stable drop

The shape that the drop takes up depends on the adhesive forces between the molecules of the solid and liquid phases. The wettability of a given solid surface to a given liquid is defined in terms of the contact angle q (Figure 16). For a solid/liquid interface which exhibits a small contact angle (<90 degrees), the solid is preferentially wetted by the liquid. Thus in Figure the solid is preferentially water wet. If $q = 0$ degrees, then the solid is totally water wet. When two liquids are present and brought into contact with a solid, one of the liquids will preferentially wet the solid. Most natural minerals are water wet. When water wet solids enter an emulsion the solids tend to agglomerate with the water, and settle out. To overcome this problem surfactants are added to the oil phase to change the solids from being water wet to being oil wet. The soaps added as emulsifiers will also act as wettability control agents, but special surfactants are more effective. The stability of the emulsion can be tested by measuring the conductivity of the mud. The stronger the emulsion the higher the voltage required for an electric current to flow. A loose emulsion is often due to water wet solids or free water. When water-wet solids are present the surface of the mud becomes less shiny and the cuttings tend to stick to each other and blind the shale shaker. Barite added for density control must also be oil wet otherwise the particles will tend to settle out.

4.3 Balanced activity

The *activity* of a substance is its affinity or potential for water. All rocks which contain clay will absorb water to some extent. This is because there is a difference between the activity of the shales and the activity of the mud. If the chemical potentials of the shale and the mud were equal the shale would not absorb any water. This would eliminate any swelling of the clays, leading to borehole instability. For balanced activity in an oil-based mud the activity of the mud (A_w) must be adjusted to equal the activity of the formation being drilled. $CaCl_2$ or $NaCl$ may be added to the mud to keep A_w above 0.75. The activity of the shale can be measured by taking samples from the shaker.

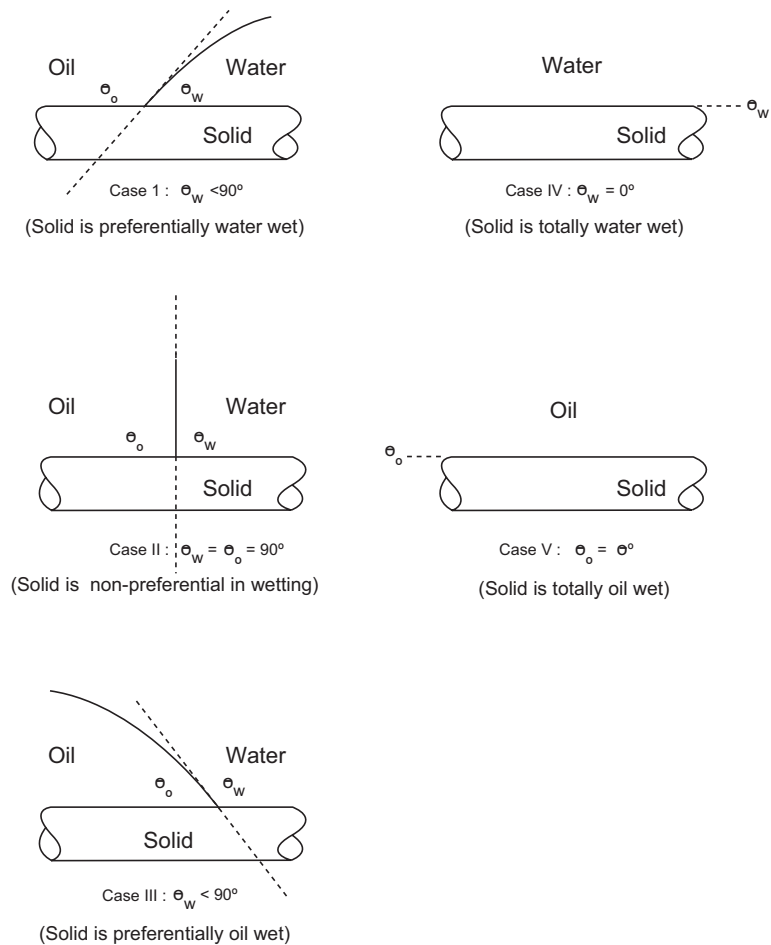

Figure 16 Contact angles in three phase systems

4.4 Viscosity control

Excessive viscosity in an oil-based mud may be the result of:

- Too much water content - When water is properly emulsified it behaves like a solid. As the water fraction increases so does the viscosity
- Drilled solids - The solids content affects viscosity in oil-based in the same way as water-based muds. The build up of fine solids (e.g. due to diamond bit drilling) may produce high PV, YP and gel strengths. Finer shaker screens (120 mesh) should be used to reduce this effect. Water wet solids may also cause problems with high YP

It is recommended that pilot tests should be done to assess the implications of adding chemicals to the mud to control viscosity. Emulsifiers and wetting agents may be added to reduce viscosity.

Water and special viscosifiers (organically treated bentonite) may be added to the mud to increase viscosity.



4.5 Filtration control

Only the oil phase in OBM is free to form a filtrate, making an oil-based mud suitable for formations which must not be damaged. The fluid loss is generally very small with oil-based muds (<3cc at 500 psi and 300 degrees F). During the test there should never be water present in the filtrate (indicates a poor emulsion). If water is present more emulsifying agent should be added. Excessive filtrate volumes can be cured by adding polymers, lignite etc. (pilot tests are recommended).

5. SOLIDS CONTROL

Solids control may be defined as the control of the quantity and quality of suspended solids in the drilling fluid so as to reduce the total well cost.

The following equation may be used to estimate the volume of solids entering the mud system whilst drilling:

$$V_c = \frac{(1 - \phi)d^2(ROP)}{1029}$$

where,

V_c = volume of cuttings (bbl/hr)

ϕ = average formation porosity

d = hole diameter (in)

ROP = rate of penetration (ft/hr)

Thus for a typical North Sea well ($d = 26"$, $ROP = 62$ ft/hr, $\phi = 0.25$)

$$V_c = \frac{(1 - 0.25) \times 676 \times 62}{1029} = 30 \text{ bbl / hr}$$

Therefore 30 bbls of solids have to be removed by the solids control equipment every hour. Solids control is the most expensive part of the mud system since it is operating continuously to remove unwanted solids. It is generally cheaper to use mechanical devices to reduce the solids content rather than treat the mud with chemicals once the solids have become incorporated in the drilling fluid.

The solids which do not hydrate or react with other compounds within the mud are described as "inert". These may include sand, silt, limestone and barite. All of these solids (except barite) are considered to be undesirable since:

- (i) They increase frictional resistance without improving lifting capacity.
- (ii) They cause damage to the mud pumps, leading to higher maintenance costs.
- (iii) The filter cake formed by these solids tends to be thick and permeable. This leads to drilling problems (stuck pipe, increased drag) and possible formation damage.

It is these solids which must be removed to allow efficient drilling to continue. However some particles in the mud (e.g. Barite, Bentonite) should be retained since

they are required to maintain the properties of the mud. If these desirable solids are removed they must be replaced by more additions at surface which will increase the mud cost.

For most practical purposes the mud solids can be divided into two groups according to their density:

- (i) Low gravity solids s.g. = 2.5 - 3.0
- (ii) High gravity solids s.g. = 4.2 (barite).

Drilling fluids will contain different proportions of each type of solid (e.g. to maintain hydrostatic mud pressure high gravity solids must be added, and so this type of mud should contain fewer low gravity solids). Solids control in muds containing barite (weighted muds) requires special procedures to ensure that barite is not discarded along with the undesirable solids. Mud containing low gravity solids only (unweighted muds) have a density of 8.5 - 12 ppg.

There are three basic methods used to control the solids content of a drilling fluid:

a. Screening

A shale shaker uses a vibrating screen to separate the solids according to size. Material too large to pass through a given mesh size will be discarded while the finer material will undergo further treatment.

b. Settling

For natural settling of solid particles under laminar conditions Stokes Law applies:

$$V_s = \frac{2gd_c^2(\rho_s - \rho_m)}{92.6\mu}$$

where

- V_s = slip or settling velocity (ft/sec)
- g = acceleration due to gravity (ft/sec²)
- d_c = largest cutting diameter (ft)
- ρ_m = mud density (lb/ft³)
- ρ_s = cutting density (lb/ft³)
- μ = mud viscosity (cps)

Basically the solids will settle out more readily when:

- (i) The solid particles are large and heavy.
- (ii) The mud is light and has a low viscosity.
- (iii) The gravitational force can be increased by mechanical means.

When the viscosity of the mud is increased (to improve lifting capacity) solids settling becomes more difficult. For practical purposes the natural settling rate is far too slow, so mechanical devices are introduced to remove the solids. Hydrocyclones and centrifuges increase the gravitational force on the solid particles, and so the process is sometimes called “forced settling”.



c. Dilution

After passing through all screening and settling stages there will still be a very fine solids content which remains in the mud. This can either be discarded or diluted. Due to the limited capacity of the active system some mud is usually discarded (together with desirable solids and other chemicals) before the remainder can be diluted and conditioned for re-circulating.

5.1 Solids Control Equipment

The mechanical components of solids control are:

a. Vibrating Screens

The screen is designed to remove the particles which will not pass through the mesh. At the same time the screen is vibrated to prevent blinding or plugging which would lower its efficiency. The size of the mesh on most shale shakers is 10 - 14 API mesh. (A 10 mesh screen has 10 openings per inch along each side). Many of the cuttings will pass through the 10 mesh screen since they have disintegrated due to erosion and hydration. For this reason a finer mesh (80 openings per inch) may be used. The screens can be arranged in series so that a finer mesh is put beneath the coarser mesh. Sometimes the screens are arranged in parallel to handle larger volumes, with a slight overlap to ensure no cuttings by-pass the screening. It must be remembered that the use of a finer screen means that the flow area of the screen is reduced. While drilling surface hole a large volume of cutting must be screened so there may be a physical limitation on the size of the mesh (unless the area of the screen can be increased). Fine screens are also susceptible to damage and need to be replaced. Oblong screens are sometimes used to extend the life of the screen. The mesh is different in each direction, which allows the use of heavier wire (i.e. 30 x 70 mesh). This increases the flow rate capacity but the cleaning efficiency is reduced.

As can be seen from the particle size distribution (Figure 17) an 80 mesh screen will only remove a small percentage of the total solids in the mud. Due to the small size of the particles the most convenient unit of measurement is the micron (1 inch = 25400 microns). The API

classification defines 3 sizes of particle as shown in Figure 17

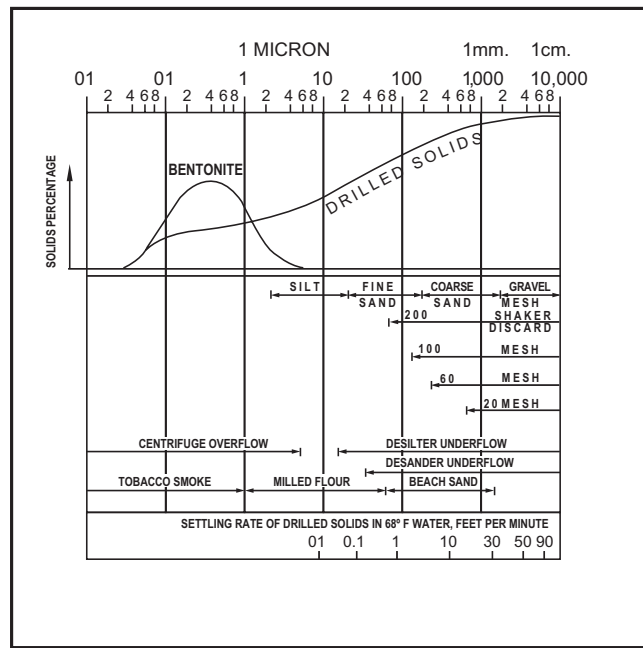

Figure 17 Particle Size Distribution for Solids

- **Sand** describes any particle > 74 microns. (Such particles may actually be shale or LCM, but they are sand size). This corresponds to material retained on a 200 mesh screen.
- **Silt** describes any particle between 2 and 74 microns.
- **Colloidal** describes any particle < 2 microns.

Notice from Figure 17 that barite comes within the silt category and bentonite is colloidal. API specifications for barite require that 97% of particles will pass through a 200 mesh screen. Screen sizes finer than 200 mesh cannot be used in weighted muds since the cost of replacing the discarded barite would be prohibitive.

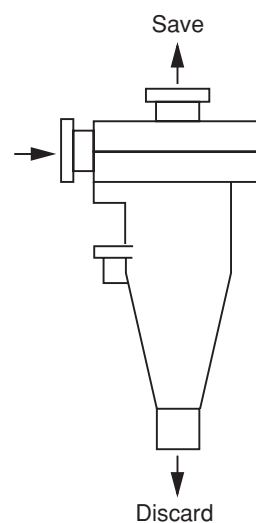

Figure 18 Normal hydroclone operation

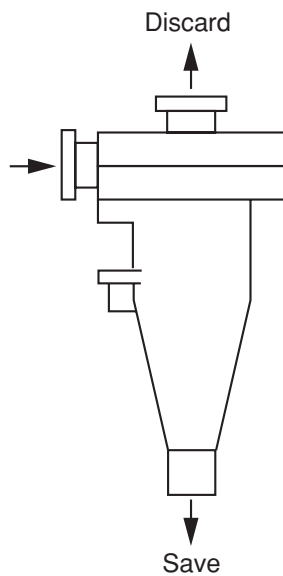

Figure 19 Barite salvage system where the solids in the underflow are saved

b. Hydrocyclones

Hydrocyclones are designed to remove all the sand particles and most of the silt particles from the mud while retaining the colloidal fraction. Hydrocyclone is a general term which includes **desanders** (6" diameter or greater), **desilters** (generally 4" diameter), and clay ejectors (2" diameter). The operating principle of the hydrocyclone is the same irrespective of size (Figure 18). A centrifugal pump feeds mud tangentially at high speed into the housing, thus creating high centrifugal forces. These forces multiply the settling rate so that the heavy particles are thrown against the outer wall and descend towards the outlet (underflow). The lighter particles move inwards and upwards as a spiralling vortex to the liquid discharge (overflow). Hydrocyclones are designed so that only solids (plus small volume of fluid) passes out the underflow. This should appear as a “spray discharge” and not “rope discharge”. Rope discharge is an indication of solids overloading, and the underflow will soon plug off completely.

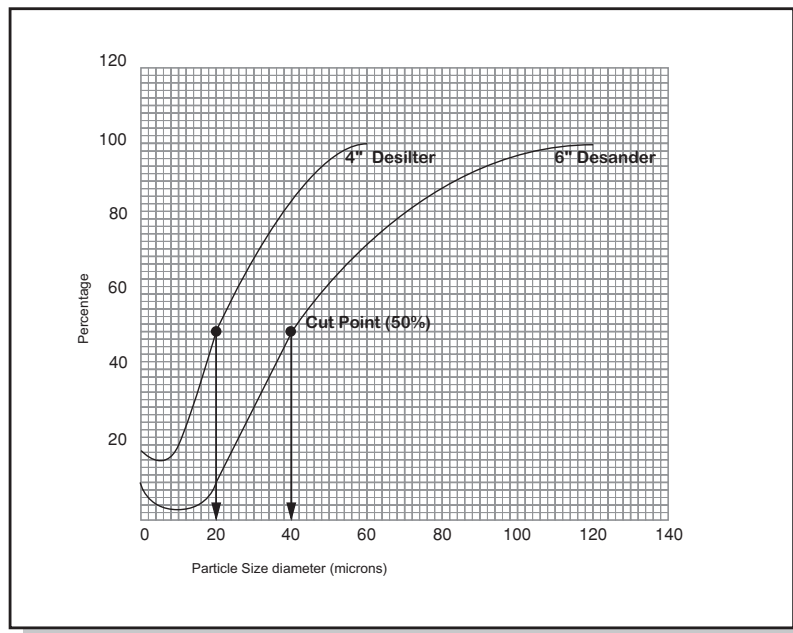

Figure 20 Hydrocyclone Cut-off Points

Figure 18 shows the normal operation of a hydrocyclone with the solids being discarded. The cut point of a hydrocyclone is the particle size at which 50% of the particles of that size will be discarded (Figure 20). A typical cut point for a desander is 40 microns and for a desilter 20 microns. Since the particle size of barite lies between 2 and 80 microns hydrocyclones cannot be run with weighted muds since about half the barite would be removed through the underflow. Notice that for a clay ejector (Figure 19) the outlets are reversed (i.e. the underflow containing valuable barite is returned to the active system while the overflow containing finer material is discarded). Such devices are installed for barite salvage for weighted muds. Notice that there are no internal moving parts in a hydrocyclone, the separation is due solely to the settling action of particles with different densities.

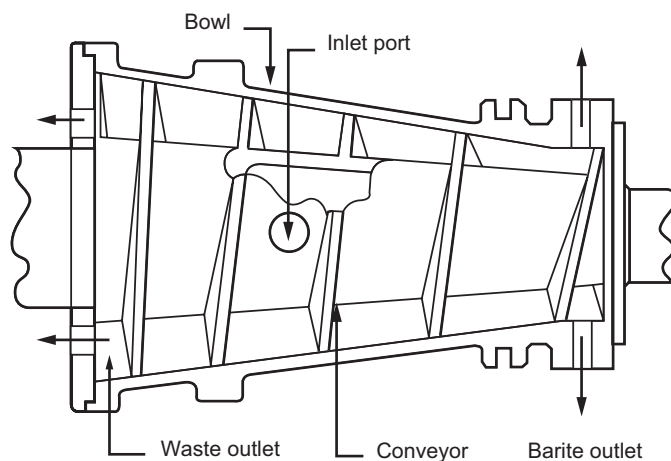

Figure 21 Decanting centrifuge



c. Decanting Centrifuge

Centrifuges were first introduced to control solids and to retain the barite in weighted water based muds. However they may also be used in unweighted muds and oil muds to process the hydrocyclone underflow and return the liquid colloidal fraction to the active system.

A decanting centrifuge is shown in Figure 21. It consists of a rotating cone shaped bowl and a screw conveyor. As the centrifuge rotates at high speed the heavier particles are thrown against the side of the bowl. The screw conveyor moves these particles along the bowl and carries them towards the discharge port. At the opposite end is another port where liquid containing the finer particles is discharged.

For a weighted mud the underflow from the shale shaker is led to the centrifuge (no hydrocyclones used). The solids discharged through the underflow contain valuable barite and are returned to the active system. Centrifuges are more efficient than hydrocyclones for barite salvage since they make a finer particle cut. Under proper operating conditions 90 - 95% of barite can be salvaged. When drilling hydratable shales the finer drill solids must be controlled. The finer solids in the liquid phase are normally discarded, although this will also contain chemicals and barite.

For an unweighted mud the underflow from the desilters is led to the centrifuge. This time the liquid phase, containing the fine material (including bentonite), will be returned to the mud, while the solids will be discarded. This is often used in oil-based muds where the liquid phase will contain base oil which is expensive to replace. Water wet solids in an oil-based mud can be difficult to control, but a centrifuge can separate them from the liquid-colloidal phase. The solids are then dumped since they cannot be re-used.

d. Mud Cleaner

A mud cleaner is designed to remove drill solids larger than barite. It consists of a desilter and a screen, and so removes solids in two stages. It is used for a weighted mud to remove solids while retaining barite.. First the mud passes through the shale shaker, which should be as fine as possible and still accommodate the full mud flow. The underflow is then passed through a bank of desilters, where the overflow (lighter material) is returned to the active system. The underflow is directed onto the screen (usually 150 - 200 mesh). The barite particles will pass through and are returned to the system (together with very fine solids). The solids separated out by the screens are discarded. Mud cleaners have been developed by most mud companies under the names "silt separator" or "sand separator". They can be used with decanting centrifuges if necessary. Both weighted and unweighted muds can be processed, as can oil-based muds. They are best suited for muds less than 15 ppg. (For heavier muds a centrifuge is better.)

5.2 Solids Control Systems

The components discussed above are configured in such a way as to remove the unwanted solids as efficiently as possible whilst ensuring that the solids which are mixed into the mud to maintain viscosity (Bentonite) and density (Barite) are not removed from the system.

a. Unweighted Muds (Figure 22)

When configuring a system for an unweighted mud, the various solids control components are arranged in decreasing order of particle size removed to prevent clogging. Dilution is used upstream of the hydrocyclones to increase their separation efficiency. Having passed through the solids control equipment the mud should consist of water, well-dispersed bentonite and very fine drill solids. It can then be diluted, treated with chemicals, and conditioned, prior to being re-circulated.

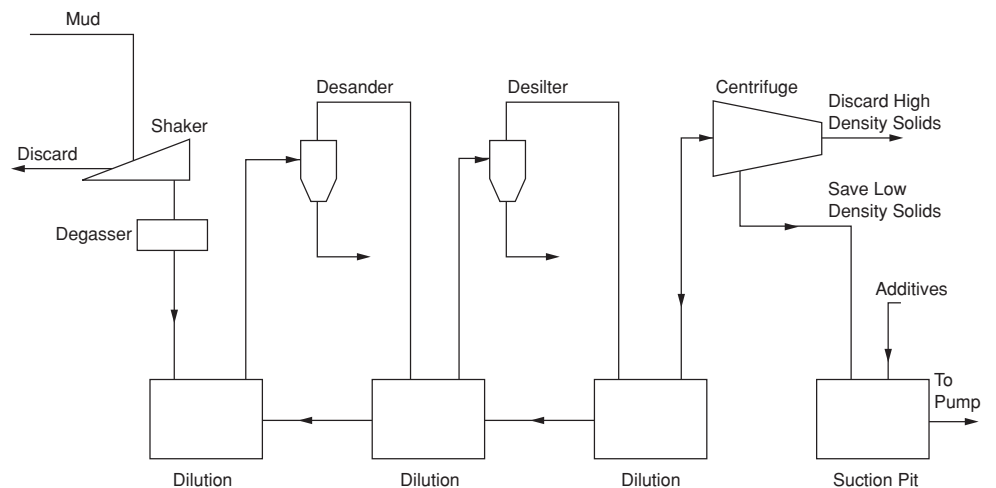

Figure 22 Solids Control System for an Un-weighted Mud

b. Weighted Muds (Figure 23)

Hydrocyclones cannot be used alone for weighted muds since they will discard barite. A mud cleaner may however be used to overcome this problem. As with unweighted muds water is used for diluting upstream of the mud cleaner and the centrifuge. Notice that the low density solids in the liquid phase are discarded from the centrifuge, while the solids (barite) are retained. The chemicals and bentonite discarded with the liquid phase must be replaced. The optimum solids content in a weighted mud is difficult to determine.

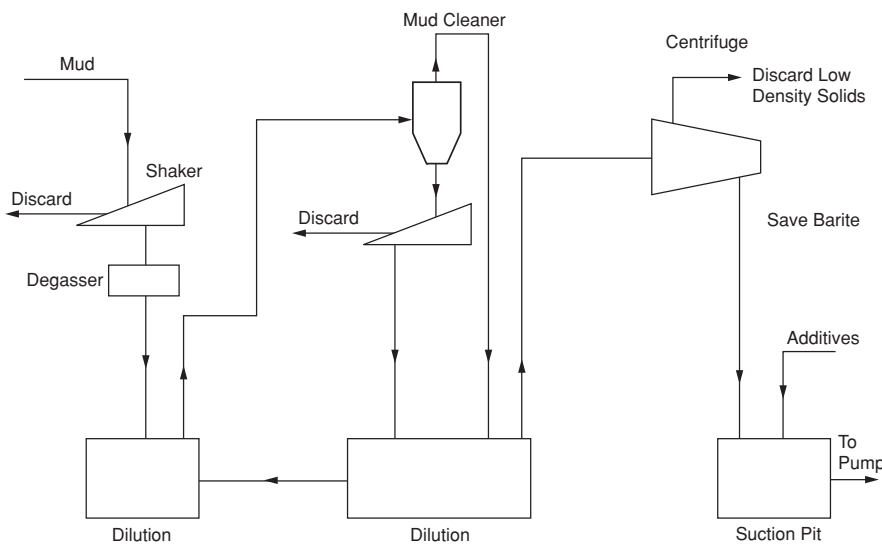

Figure 23 Solids Control System for a Weighted Mud

APPENDIX 1

CLAY CHEMISTRY

1. Introduction

The group of minerals classified as clays play a central role in many areas of drilling fluid technology. The clay group can be described chemically as aluminium silicates. Since the elements that constitute the clays account for over 80 % of the mass of the earth (aluminium 8.1%, silicon 27.7% and oxygen 46.6%) it can readily be appreciated that virtually every stage in the drilling of a hole will bring contact with clay. Clays are often used to derive the viscous properties of the drilling fluid and since clays will also be encountered during the drilling of the hole many of the chemicals used to 'condition' the mud are used to control these properties.

2. BASIC FEATURES OF CLAYS

There are a number of features of the clay minerals that distinguish them as a group. The most important one is the chemical analysis which shows them to be composed of essentially silica, alumina water and frequently with appreciable quantities of iron and magnesium and lesser quantities of sodium and potassium. The upper limit of the size of clay particles is defined by geologists as 2 microns, with a mica like structure with the flakes composed of tiny crystal platelets, normally stacked together face-to-face. A single platelet is called a unit-layer.

2.1 Fundamental Building units

There are two simple building units from which the different clay minerals are constructed :

Octahedral Layer

This unit consists of two sheets of closely packed oxygen or hydroxyl atoms into which aluminium, iron or magnesium atoms are embedded in an octahedral structure. When aluminium is present, only two thirds of the ionic positions required to balance the structure are filled (Gibbsite $\text{Al}(\text{OH})_3$). When magnesium is present, all the positions are filled, thus creating a balanced structure (brucite, $\text{Mg}(\text{OH})_2$).

Tetrahedral Layer

In each tetrahedral unit, a silicon atom is located in the centre of a tetrahedron, equidistant from four oxygen atoms, or hydroxyls. The base of the silica tetrahedral groups are arranged to form a hexagonal network, which is repeated infinitely to form a sheet of composition, $\text{Si}_4\text{O}_6(\text{OH})_6$.

These layers are tied together by sharing common oxygen atoms. It is the different combinations of these units and modification of the basic structure that give rise to the range of clay minerals with different properties. The two predominant units are the alumina octahedral sheet and the silica tetrahedral sheet.

3. STRUCTURE OF CLAY MINERALS

The clay minerals are built up by different ratios of silica layer to octahedral layers. Different combinations of layers and chemical modification of layers have given rise to over 26 different clay minerals. The most important clay minerals of interest to the drilling fluid engineer are kaolin, mica, illite, montmorillonite, sepiolite, attapulgite and chlorite. Before the structures and therefore the effects of the clay minerals can be discussed in any detail, the two mechanisms by which electrical charges may be developed on the clay surfaces, must be described.

4. CHARGES ON CLAY SURFACES

Charges on clay surfaces arise from two mechanisms. One is related to the structure of the clay and is a characteristic of the particular mineral. The other arises from the broken edges.

a. Isomorphous Substitution

The idealised combinations of silica tetrahedra and aluminium octahedra sheets give structures in which the charges are balanced and are electrostatically neutral. However, if a metal ion within the layers is replaced by an ion of lower charge valency, a negative charge is created. For example, in the tetrahedral layer, some of the silica may be replaced by iron, or in the octahedral layer some of the aluminium may be replaced by magnesium. This creates a negative potential at the surface of the crystal structure.

The pattern of isomorphous substitution is random and varies in the different minerals according to the following :



-
- (a) Tetrahedral or octahedral substitution
 - (b) Extent of substitution
 - (c) The nature of the exchanged cations, i.e. Na, K or Ca.

The negative charge on the clay lattice created by isomorphous substitution is neutralised by the adsorption of a cation. In the presence of water the adsorbed cations can exchange with other types of cations in the water. This gives rise to the important property of the clays known as cation exchange capacity, because the ions of one type may be exchanged with ions of the same or different type. This property is often used to characterise clays, shales and drilling fluid and is determined by measurement of the adsorption of a cationic dye, methylene blue. The result is quoted as the milli-equivalents of dye adsorbed per 100g of dry clay. The replaceability of cations depends on a number of factors such as:

- Effect of concentration
- Population of exchange sites
- Nature of anion
- Nature of cation
- Nature of clay mineral.

This large number of variables creates a complex system to analyse. It has been shown that different ions have different attractive forces for the exchange sites. The relative replacing power of cations is generally $\text{Li}^+ < \text{Na}^+ < \text{K}^+ < \text{Mg}^{++} < \text{Ca}^{++} < \text{H}^+$. Thus at equal concentrations, calcium will displace more sodium than sodium will displace calcium. If the concentration of the replacing cation is increased, then the exchanging power of that cation is also increased. For example, high concentrations of potassium can replace calcium. Also, in some minerals such as mica, potassium is particularly strongly adsorbed and not easily replaced, except by hydrogen.

b. Broken Edge Charges

When a clay sheet is broken, the exposed surface will create unbalanced groups of charges on the surface. Some of the newly exposed groups have the structure of silica, a weak acid, and some have the structure of alumina or magnesia, a weak base. Therefore, the charge on the edge will vary according to the pH of the solution. One of the reasons for the pH values of drilling fluid to be kept on the alkaline side is to ensure that the clay particles are only negatively charged so that electrostatic interactions are kept at a minimum. Chemical treatment of drilling fluids is often aimed at a reaction with the groups on the broken edges. Since the edge surface is created by grinding or breaking down the clays, chemical treatment costs can be minimised by ensuring that the formation clays are removed as cuttings, rather than broken down at the bit into finer sized particles.

5. CLAYS IN DRILLING FLUIDS

Clays play a significant role in drilling fluids. They may be added intentionally to control viscous flow properties and fluid loss or they may build up in an uncontrolled fashion in the drilling fluid whilst drilling through a clay formation. In both cases

control of the resulting flow properties must be maintained. These properties may be modified intentionally by chemical treatment or as a consequence of drilling through water soluble formations, such as cement, anhydrite, salt or magnesium.

5.1 Particle Associations

The associations between clay particles are important as they affect viscosity, yield point and fluid loss. The terms describing the associations are as follows :

Deflocculated System

A system of suspended particles is described as de-flocculated or dispersed, when there is an overall repulsive force between the particles. This is normally achieved by creating the conditions in which the particles carry the same charge. In clay system under alkaline conditions, this is normally a net negative charge.

Flocculated Systems

A system may be described as flocculated when there are net attractive forces for the particles and they can associate with each other, to form a loose structure.

Aggregated Systems

Clays consist of a basic sheet structure, and the crystals consist of assemblages of the sheets, one upon the other. During clay swelling the sheets can be separated. The sheets may then form aggregated systems. These aggregates may be flocculated or deflocculated.

Dispersed Systems

A system in which the breakdown of the aggregates is complete is called a dispersed system. The dispersed particles may be either flocculated or deflocculated.

5.2 Interparticle Forces

The forces acting on clay particles may be either repulsive or attractive. The particles approach each other due to Brownian motion. The particle associations that they assume will depend on the summation of these forces.

a. Repulsive Forces

Electrical Double Layer Repulsion

The clay particles have been described as small crystals that have negatively charged surfaces. A compensating charge is provided by the ions in solution that are electrostatically attracted to the surface. At the same time there is a tendency for the ions to diffuse away from the surface, towards the bulk of the solution. The action of the two competitive tendencies results in a high concentration of ions near the surface, with a gradual falloff further from the surface. The volume around the clay surface is called the Diffuse or Gouy Layer. The thickness of the layer is reduced by the addition of salt or electrolyte.

When two particles approach each other there is an interference that leads to changes in the distribution of ion in the double layer of both particles. A change infers that energy must be put into the system and once this is not the case there must be a repulsive force between the particles, that will become larger as the particles come



closer together. However, since the electric double layer can be compressed by electrolytes, then as the electrolyte concentration is increased so the particles can approach closer to each other before the repulsive forces are significant.

b. Attractive Forces

Van der Waals Forces

Van der Waals forces arise through the attraction of the spontaneous dipoles being set up due to distortion of the cloud of electrons around each atom (Van der Waals dipoles). For two atoms, the attractive force decays very rapidly with distance ($1/d^7$) but for two spherical particles, the force is inversely proportional to only the third power of the distance ($1/d^3$). Thus, for a large assemblage of atoms, such as in a clay platelet, this force can be significant as it is additive. The attractive force is essentially independent of the electrolyte concentration.

5.3 Deflocculation Mechanisms

To maintain a system in a deflocculated state the repulsive forces must be maximised. This can be achieved by two mechanisms.

Low Salt Concentrations

In order to maximise the electrostatic repulsion, the electrolyte concentration has to be as low as possible.

Maximum Negative Charge

The conditions have to be chosen so that the negative charges on the clay particles are at a maximum. This can be done in two ways:

(1) High pH conditions

A pH of above 8.0 will increase the number of negative silicic acid groups on the clay edges. Thus, maintenance of alkaline pH conditions with caustic soda will stabilise the clay system.

(2) Addition of deflocculants or dispersants

There is a wider range of chemicals known as dispersants or thinners, that have a wide range of chemical structure. However, they can all be described as negatively charged polymers which can neutralise a positive charge on the edge to become adsorbed. Then, the other negative groups increase the negative charge density on the clay platelet. Since the deflocculants are reacting with the positive sites on the edges, and the edge surface area is relatively a small proportion of the total, the chemicals can be effective at low dose rates. Also note that the materials tend to be acidic. Thus, caustic soda additions should also be made with the thinner. The other fine particulate solids, such as sand, calcium carbonate or barites, will react in essentially the same way.

5.4 Flocculation mechanisms

In many drilling fluid systems the clays are deflocculated and the change to a flocculated condition can drastically alter the fluid properties. There are a number of mechanisms by which the interparticle attractive forces can be increased and repulsive forces decreased:

High Salt Concentrations

Higher salt levels allow the particles to approach each other close enough for the shorter range attractive forces to predominate. The upper limit of salinity, for bentonite to yield satisfactorily, is about 2% sodium chloride. In drilling practice this reaction occurs when a fresh-water clay-based fluid is used to drill into a salt section when a fresh-water system has salt added to it in preparation to drill evaporite sequences.

Polyvalent Cations

A soluble cation containing more than one positive charge can react with more than one exchange site on the surfaces of more than one clay platelet, to form an ion bridge between the clays to produce a flocculated structure. Calcium is the most common ion, although aluminium, magnesium and zirconium are other examples. Calcium is often encountered in the form of gypsum (calcium sulphate) and cement. If the clays in the drilling fluid are in the sodium form, then the contact with calcium will drastically alter the properties. Some mud systems overcome this problem by ensuring that the clays are already in the calcium form before the contaminant is encountered. Thus, lime or gypsum are added in excess to ensure a source of calcium is available. The aluminium and zirconium ions have been suggested as treatments for production sands to flocculate the clay minerals and thus prevent their mobilisation to block the pores of the production zone. The flocculation is followed by aggregation of the clays.

Addition of Polymeric Flocculants

These polymers extend the concept of an “ion bridge” or the polyvalent cations, to a polymer bridge between clay platelets. The main feature of the flocculants is a very high molecular weight, so that the molecule spans the distance between particles. The molecules must also adsorb onto the particles, so the presence of anionic or cationic groups often makes the molecules more effective. There are two cases where the polymeric flocculants are used. One is in clear-water drilling where the drilled solids are removed by the flocculant in order to keep the density low. The other is where the polymer is added to stabilise a hydrateable formation.

Low pH Conditions

Since the edge charges are pH dependent, a low pH will generate more positive sites and encourage face to edge association. Values of pH below 7, and no caustic soda treatment, would probably induce this reaction. Acid may be added to flocculate drilled solids in a sump clean-up operation.

6. MONTMORILLONITE CLAY

Montmorillonite is the major clay mineral in bentonite or fresh water gel, and is the most common mineral in a group of minerals called the smectites. The essential feature that gives rise to the expandable structure is that the ionic substitutions are mainly in the octahedral layer. Thus, the charge is in the centre of the layer, so that the cations that are associated with the mineral to balance the ionic charge are unable to approach the negative charge sites close enough to completely counterbalance the ionic character of the cation on the mineral surface. This residual ionic character



provides the attractive force for the adsorption of polar molecules such as water, between the unit sheets. The unique properties of montmorillonite are due to the very large area available when the clay expands and hydrates fully to just single sheets. Table 3 gives the surface areas for kaolin, illite and montmorillonite determined by adsorption of a non-polar molecule, nitrogen, and polar water molecules. It will be seen that montmorillonite has the greater available area to the polar adsorbent. The swelling behaviour is most dependent on the type of cation in the exchangeable sites. This will be discussed in terms of sodium and calcium, since these are the most common soluble ions. A monovalent cation, such as sodium, can associate with a charge deficient area such that dispersion in water will create separated sheets. A divalent cation, such as calcium, cannot effectively associate with two negative charge centres on one sheet, and thus must bind two sheets together. Contact with water can cause swelling and mechanical dispersion may separate a sheet, but the ultimate surface area available and the volume of closely associated water will be considerably lower than with the sodium system. Natural bentonite occurs as the calcium form. The deposit in Wyoming is fairly unique in that it is predominantly in the sodium form and thus hydrates and expands more fully. This clay is preferred as a drilling mud additive because the desired viscosity is obtained at low concentrations. The calcium clays are often chemically treated with sodium carbonate to partially convert them to the sodium form. Expandable montmorillonite can exist in substantial quantities in shales as the result of volcanic ash falling into a marine environment. The shales show the expected reaction to water in that the clays expand, and the high surface area gives a plastic, sticky cutting when being drilled. The clays are often termed **Gumbo clays**.

Hydraulics 10

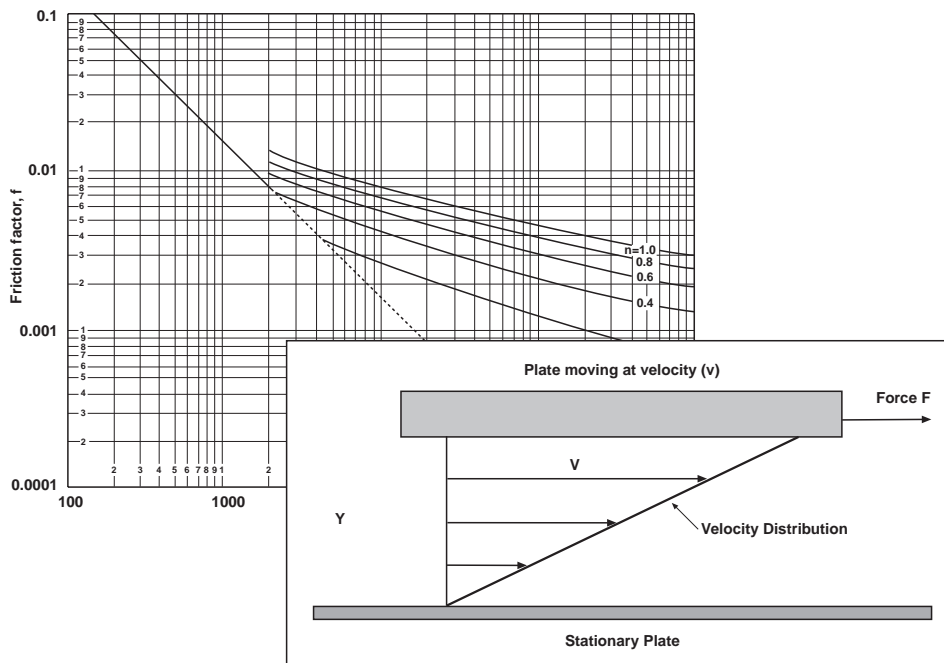

CONTENTS

1. GENERAL INTRODUCTION
2. FLOW REGIME AND REYNOLDS NUMBER
 - 2.1 Introduction
 - 2.2 Determination of the Laminar/Turbulent Boundary in a Newtonian Fluid:
3. RHEOLOGICAL MODELS
 - 3.1 Introduction
 - 3.2 Newtonian Model :
 - 3.3 Non-Newtonian Models
 - 3.3.1 Introduction
 - 3.3.2 Bingham Plastic Model
 - 3.3.3 Power Law Model
4. FRICTIONAL PRESSURE DROP IN PIPES AND ANNULI
 - 4.1 Laminar Flow in Pipes and Annuli
 - 4.1.1 Newtonian Fluids
 - 4.1.2 Bingham Plastic Fluids
 - 4.1.3 Power Law Fluid
 - 4.2 Turbulent Flow
 - 4.2.1 Determination of Laminar/Turbulent Boundary in a Non Newtonian Fluids
 - 4.2.2 Turbulent Flow of Newtonian Fluids in Pipes
 - 4.2.3 Extension of Pipe Flow Equations to Annular Geometry
 - 4.2.4 Turbulent Flow of Bingham Plastic Fluids in Pipes and Annuli
 - 4.2.5 Turbulent Flow of Power Law Fluids in Pipes and Annuli
5. FRICTIONAL PRESSURE DROP ACROSS THE BIT
6. OPTIMISING THE HYDRAULICS OF THE CIRCULATING SYSTEM
 - 6.1 Designing for Optimum Hydraulics
 - 6.2 Pressure Losses in the Circulating System
 - 6.3 Graphical Method for Optimization of Hydraulics Programme





LEARNING OBJECTIVES

Having worked through this chapter the student will be able to:

General:

- Describe principle functions of a drilling fluid and the objectives of optimising the hydraulics of the circulation system.
- Describe the impact of hydraulic horsepower on the penetration of a drillbit.

Flow Patterns and Reynolds Number:

- Define the terms: laminar and turbulent flow.
- Define the non-dimensional number - Reynolds number and state its relationship to laminar and turbulent flow.
- Describe the relationship between Reynolds number and the laminar/turbulent transition in Newtonian and non-Newtonian fluids.

Rheological Models:

- Describe in general terms, graphically and mathematically the: Newtonian; Power Law and Bingham Plastic rheological models.
- Describe the rheological models which best describe the various types of drilling fluid and cement slurries.

Frictional Pressure Drop for Laminar flow in Pipes and Annuli:

- Describe in general terms the factors which influence the pressure drop in a drilling system.
- Describe the equations and the influential factors involved in the calculation of pressure drop of Newtonian, Bingham Plastic and Power Law fluids in pipes and annuli.
- Calculate the frictional pressure drop for laminar flow in Pipes and annuli.

Frictional Pressure Drop for Turbulent Flow:

- Describe in general terms the factors which influence the pressure drop in a drilling system.
- Describe the equations and the influential factors involved in the calculation of pressure drop of Newtonian, Bingham Plastic and Power Law fluids in pipes and annuli.
- Calculate the frictional pressure drop for turbulent flow in Pipes and annuli.

Frictional Pressure Drop Across a Bit:

- Describe in general terms the factors which influence the pressure drop across a nozzle.
- Describe the equations and the influential factors involved in the calculation of pressure drop of fluids passing through a nozzle .

Optimization of Hydraulics:

- Describe in general terms the objectives and methods of optimising the hydraulics at the drill bit.
- Describe the technique for determining the optimum hydraulics at a drillbit using the hydraulic horsepower criteria.
- Use the graphical method for determining the optimum hydraulics of a circulating system.

1. GENERAL INTRODUCTION

One of the primary functions of drilling fluid is to carry drilled cuttings from the bit face, up the annulus, between the drillstring and wellbore, to surface where they are disposed of. A significant amount of power is required to overcome the (frictional) resistance to flow of the fluid in the drillstring, annulus and through the nozzles in the bit. The magnitude of the resistance to flow is dependant on a number of variables, which will be discussed below. The resistance is however expressed in terms of the amount of pressure required to circulate the fluid around the system and is therefore called the **circulating pressure** of the system. The **hydraulic power** which is expended when circulating the fluid is a direct function of the pressure losses and the flowrate through the system. Since the flowrate through all parts of the system is equal, attention is generally focused on the pressure losses in each part of the system. The pressure required to circulate the fluid through the drillstring and annulus are often called **sacrificial pressure losses**, since they do not contribute anything to the drilling process but cannot be avoided if the fluid is to be circulated around the system. The ejection of the fluid through the nozzles in the bit also results in significant pressure loss but does perform a useful function, since it helps to clean the drilled cuttings from the face of the bit. It is therefore desirable to optimise the pressure losses through the nozzles (and therefore the cleaning of the bit face) and minimise the sacrificial losses in the drillstring and annulus. The pressure losses in a typical drillstring, for a given flowrate, is shown in Figure 1.

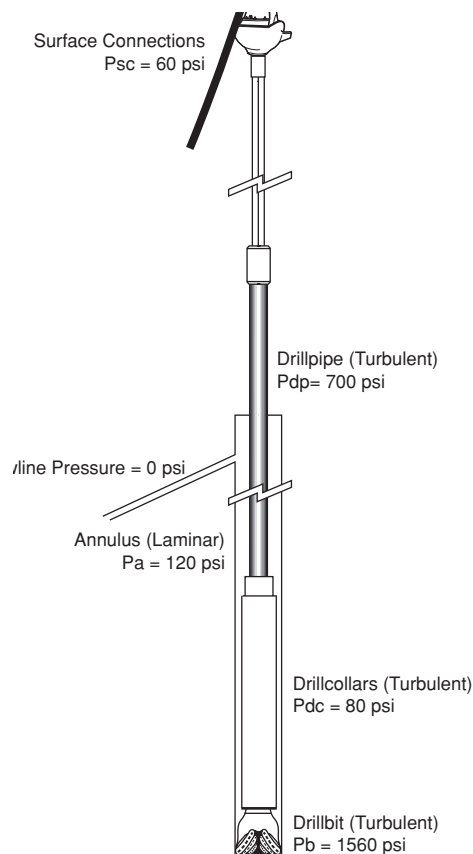

Figure 1 Pressure Losses in Drillstring, Across Nozzles, and in Annulus



The product of the circulating pressure losses and the flowrate through the system is equal to the **hydraulic power** that the mud pumps will have to generate. The units of power which are often used in drilling engineering are **horsepower** and the hydraulic power generated by the mud pumps is therefore generally referred to as the **hydraulic horsepower (HHP) of the pumps**. Mud pumps are generally rated in terms of the hydraulic horsepower that they are able to generate, and 1600 horsepower pumps are very common on modern drilling rigs. Higher pressures and flow rates require more power, and increase operating costs. The hydraulic horsepower (HHP) delivered by a pump is given by:

$$\text{HHP}_t = \frac{P_t \times Q}{1714}$$

Equation 1 Total Hydraulic Horsepower

where,

P_t = Total pressure (psi)

Q = flow rate (gpm)

The total discharge pressure is sometimes limited for operational reasons and seldom exceeds 3500 psi. The flow rate is determined by the cylinder size and the pump speed. Information on discharge pressures, pump speeds, etc. is given in manufacturers' pump tables. This expression for hydraulic horsepower is a general expression and can also be used to express the power which is expended in sacrificial losses and the power that is used to pump the fluid through the nozzles of the bit.

$$\text{HHP}_s = \frac{P_s \times Q}{1714}$$

$$\text{HHP}_b = \frac{P_b \times Q}{1714}$$

where,

HHP_s : Sacrificial Hydraulic Horsepower (hp)

HHP_b : Bit Hydraulic Horsepower (hp)

P_s : Sacrificial Pressure Losses (psi)

P_b : Bit Pressure Losses (psi)

Q : Flowrate (gpm)

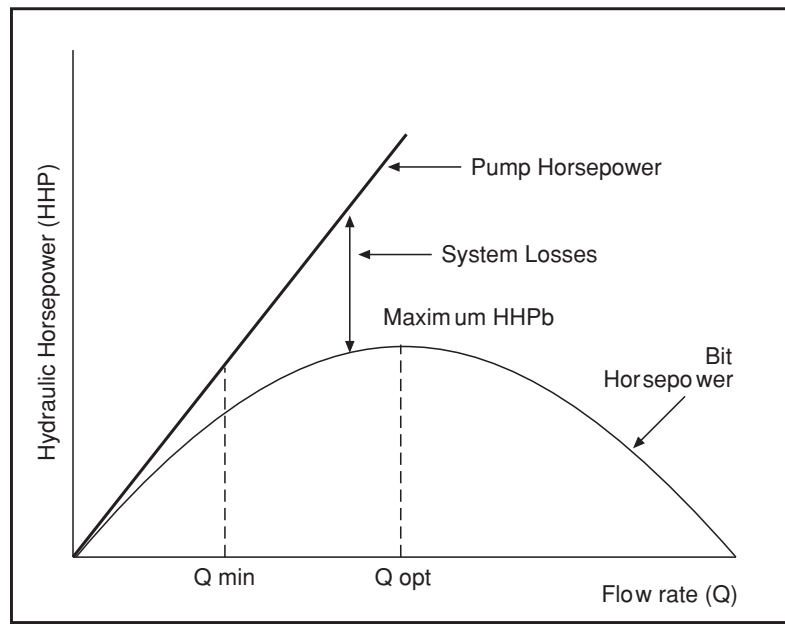

Figure 2 Horsepower Used in Drillstring and Across Nozzles of Bit

As stated above, it is desirable to optimise the pressure losses through the nozzles (and therefore the cleaning of the bit face) and minimise the sacrificial losses in the drillstring and annulus. There is, for all combinations of drillstring, nozzle size and hole size, an optimum flow rate for which the hydraulic power at the bit is maximised (Figure 2). The analysis and optimization of these pressure losses is generally referred to as, **optimising the hydraulic power of the system**. The design of an efficient hydraulics programme is an important element of well planning.

Optimization of the hydraulics of the system is a very important aspect of drilling operations. However, as stated above, the primary function of the drilling fluid is to carry the drilled cuttings to the surface. In order to do this the velocity of the fluid in the annulus will have to be high enough to ensure that the drilled cuttings are efficiently removed. If these cuttings are not removed the drillstring will become stuck and theoretical optimization will be fruitless. Considerations with respect to optimization should therefore only be addressed once the minimum annular velocity for which the cuttings will be removed is achieved. Only then, should any further increase in fluid flowrate be used to improve the pressure loss across the nozzles of the bit and therefore the hydraulic power at the bit face. If the drilled cuttings are not removed from the bit face, the bit wastes valuable effort in regrinding them instead of making new hole. This results in a significant reduction in penetration rate (Figure 3). Once the cuttings are removed from the face of the bit they must then be transported, via the drillpipe/wellbore annulus, to surface. To ensure that the cuttings are removed from the annulus the annular velocity must never be allowed to fall below a certain minimum value. This minimum annular velocity is dependent on the properties of the mud and cuttings for any particular well, and is usually between 100 - 200 ft/min

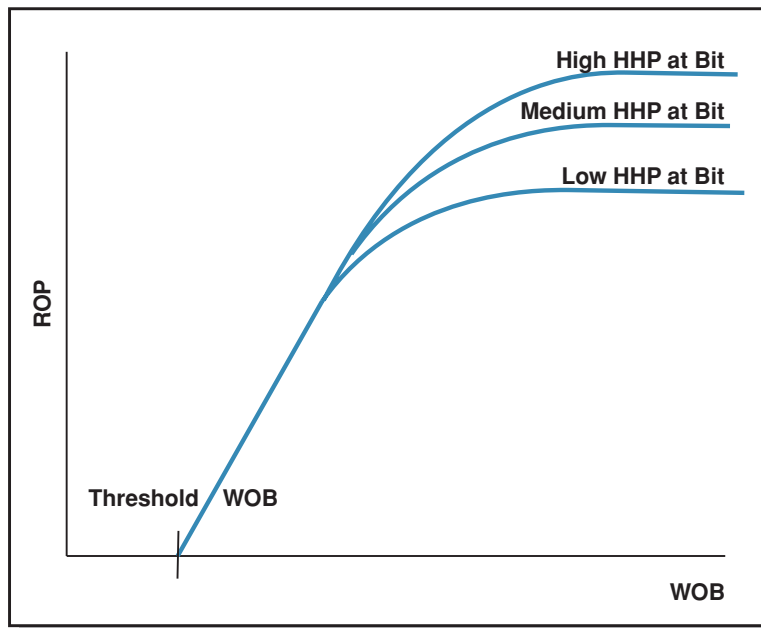

Figure 3 Impact of Horsepower at the Bit on Rate of Penetration for Given Weight on Bit

The techniques used to optimise the hydraulics of the system will be described at the end of this chapter. However, optimising the use of the hydraulic horsepower generated by the mud pumps requires the ability to quantify the pressure losses in the drillstring, across the nozzles and in the annulus between the drillstring and wellbore. The principal factors which influence the magnitude of the pressure losses in the system are:

- The geometry of circulating system (e.g. I.D. of drillpipe, length of drillpipe)
- The flowrate through the system
- The flow regime in which the fluid is flowing (laminar/turbulent)
- The rheological properties of the circulating fluid

The geometry of the system and the flowrate through the system are generally fixed

by a wide range of considerations. The geometry of the system is determined by well design and drilling operational considerations. Whilst the minimum flowrate through the system is dictated primarily by the annular velocity required to clean the drilled cuttings from the annulus. The maximum flowrate will be limited by the maximum power output by the mudpumps and the maximum pressures which can be tolerated by the pumping system.

It is therefore only necessary to understand the nature of the flow regime and rheological properties of the fluid and their influence on the pressure losses in the system.

2. FLOW REGIME AND REYNOLDS NUMBER

2.1 Introduction

The first published work on fluid flow patterns in pipes and tubes was done by Osborne Reynolds. He observed the flow patterns of fluids in cylindrical tubes by injecting dye into the moving stream. On the basis of this type of work it is possible to identify two distinct types of flow pattern (Figure 4) :

Laminar Flow (Streamline or Viscous flow) :

In this type of flow, layers of fluid move in streamlines or laminae. There is no microscopic or macroscopic intermixing of the layers. Laminar flow systems are generally represented graphically by streamlines.

Turbulent Flow :

In turbulent flow there is an irregular random movement of fluid in a transverse direction to the main flow. This irregular, fluctuating motion can be regarded as superimposed on the mean motion of the fluid.

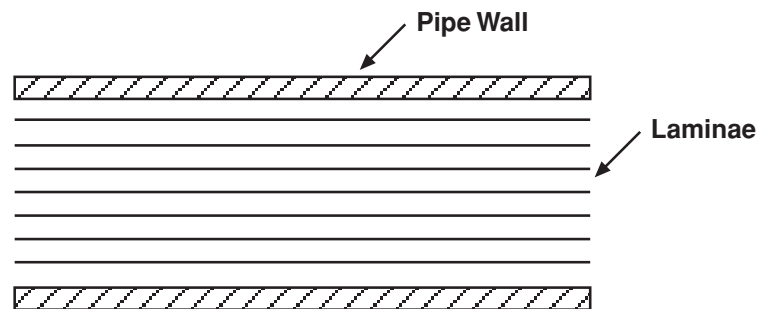

a) Laminar Flow

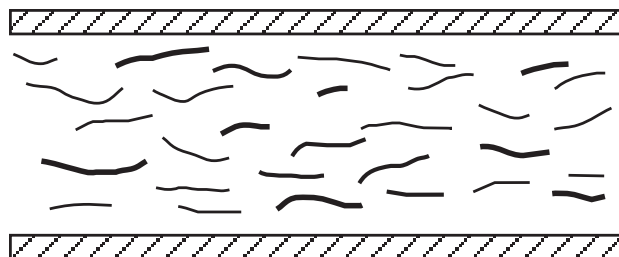

b) Turbulent Flow

Figure 4 Flow Patterns in Pipes



2.2 Determination of the Laminar/Turbulent Boundary in a Newtonian Fluid:

Reynolds showed that when circulating Newtonian fluids through pipes the onset of turbulence was dependant on the following variables:

- Pipe diameter, d ,
- Density of fluid, ρ
- Viscosity of fluid, μ
- Average flow velocity, v .

He also found that the onset of turbulence occurred when the following combination of these variables exceeded a value of 2100

This is a very significant finding since it means that the onset of turbulence can be predicted for pipes of any size, and fluids of any density or viscosity, flowing at any rate through the pipe. This grouping of variables is generally termed a dimensionless group and is known as the Reynolds number. In field units, this equation is:

$$N_{Re} = \frac{928\rho v d}{\mu}$$

Equation 2 Reynolds Number Equation

where,

- ρ = fluid density, lbm/gal
- v = mean fluid velocity, ft/s
- d = pipe diameter, in.
- μ = fluid viscosity, cp.

Reynolds found that as he increased the fluid velocity in the tube, the flow pattern changed from laminar to turbulent at a Reynolds number value of about 2100. However, later investigators have shown that under certain conditions, e.g. with non-newtonian fluids and very smooth conduits, laminar flow can exist at very much higher Reynolds numbers. For Reynolds numbers of between 2,000 and 4,000 the flow is actually in a transition region between laminar flow and fully developed turbulent flow.

EXERCISE 1 Determination of Fluid Flow Regime:

- Determine whether a fluid with a viscosity of 20 cp and a density of 10 ppg flowing in a 5" 19.5 lb/ft (I.D. = 4.276") drillpipe at 400 gpm is in laminar or turbulent flow.
 - What is the maximum flowrate to ensure that the fluid is in laminar flow ?
-

3. RHEOLOGICAL MODELS

3.1 Introduction

A mathematical description of the viscous forces present in a fluid is required for the development of equations which describe the pressure losses in the drillstring and annulus. These forces are represented by the rheological model of the fluid. The rheological models which are generally used by drilling engineers to describe drilling fluids are:

- a. Newtonian model
- b. Non - Newtonian Models the Bingham plastic model
 the power-law model.

3.2 Newtonian Model :

The viscous forces present in a simple Newtonian fluid are characterised by a single coefficient - the 'coefficient of viscosity' or as it is normally referred to the *viscosity*. Examples of Newtonian fluids are water, gases and high gravity oils. To understand the nature of viscosity, consider a fluid contained between two large parallel plates of area, A which are separated by a small distance, Y (Figure 5). The upper plate, which is initially at rest, is set in motion at a constant velocity, v. After sufficient time has passed for steady motion to be achieved a constant force F is required to keep the upper plate moving at constant velocity.

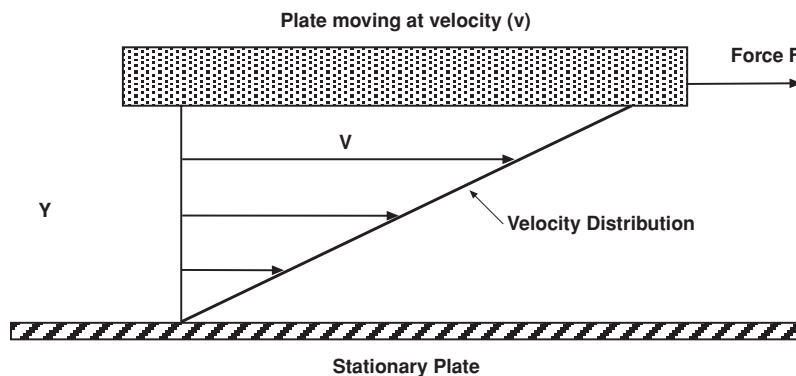

Figure 5 Model of Viscous Forces in Fluids

The relationship between these parameters can be found experimentally to be given by:

$$\frac{F}{A} = \mu \frac{V}{L}$$

The term F/A is called the *shear stress* and is generally represented by the Greek term, τ :

$$\tau = \frac{F}{A}$$

The velocity gradient v/L is an expression of the fluid **shear rate** and is generally represented by the Greek term γ :

$$\gamma = \frac{v}{L} = \frac{dv}{dL}$$

If the results of the experiment described above are plotted on a graph then the relationship would be defined by a straight line as shown in Figure 6.

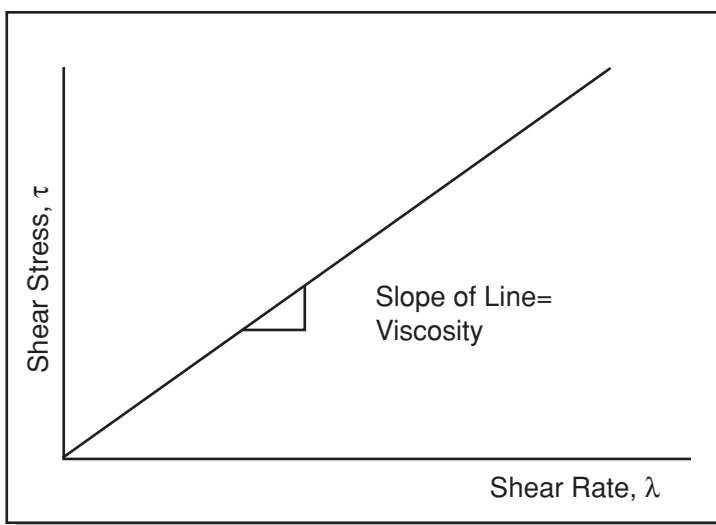

Figure 6 Shear Stress vs. Shear Rate Relationship for Newtonian Fluids

The equation of the straight line relationship is known as the **rheological model** which represents the relationship between the shear rate and shear stress and can be expressed as:

$$\tau = \mu\gamma$$

Equation 3 Shear Stress to Shear Rate Relationship for Newtonian Fluids

The constant of proportionality, μ in this equation is known as the **coefficient of viscosity** or simply, the **viscosity** of the fluid. The viscosity of the fluid therefore determines the force required to move the upper plate relative to the lower plate. The higher the viscosity the higher the force required to move the upper plate relative to the lower plate. This simple proportionality also means that if the force, F is doubled, the plate velocity, v will also double.

The linear relation between shear stress and shear rate described above is only valid for the **laminar flow of Newtonian fluids**.

3.3 Non-Newtonian Models

3.3.1 Introduction

Most drilling fluids are more complex than the Newtonian fluids described above. The shear stress to shear rate relationship of these fluids is not linear and cannot therefore be characterised by a single value, such as the coefficient of viscosity. These fluids are classified as non-Newtonian fluids. As shown in Figure 7 the shear stress of a non-newtonian fluid is not directly proportional to shear rate and this is why their relationship cannot be described by a single parameter. It is possible however to define an **apparent viscosity** which is the shear stress to shear rate relationship measured at a given shear rate. The apparent viscosity is the slope of the line between the origin and the shear stress and shear rate intercept at **any given shear rate**.

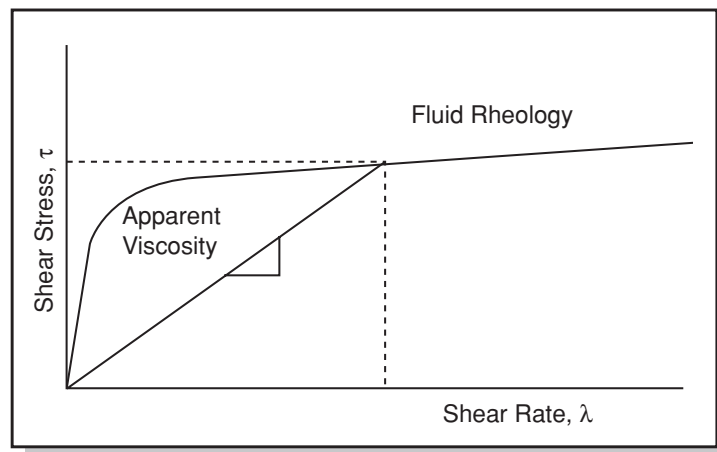

Figure 7 Shear Stress vs. Shear Rate Relationship for non-Newtonian Fluids

Non-Newtonian fluids which are shear-rate dependent are called **pseudoplastic** if the apparent viscosity decreases with increasing shear rate, and **dilatant** if the apparent viscosity increases with increasing shear rate (Figure 8). Drilling fluids and cement slurries are generally pseudoplastic in nature.

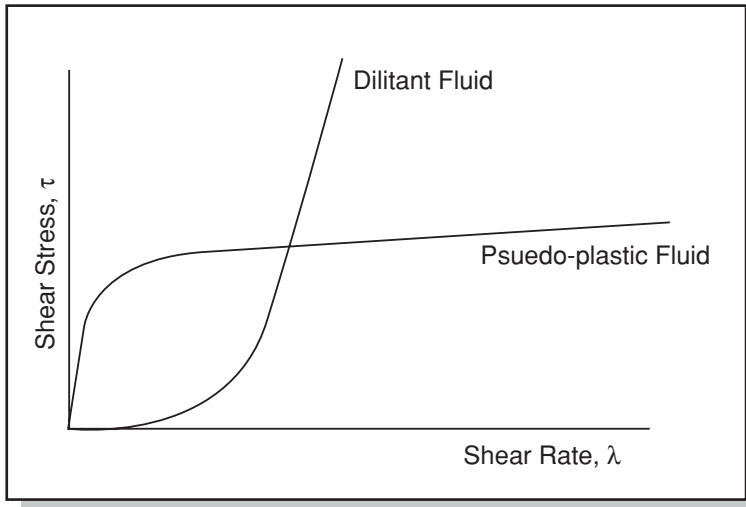

Figure 8 Shear Stress vs. Shear Rate Relationship for Pseudo-Plastic and Dilatant Fluids

There are two standard rheological models used in Drilling Engineering. These are the Bingham Plastic and Power Law Models. The Bingham plastic and power-law rheological models are used to approximate the pseudoplastic behaviour of drilling fluids and cement slurries.

3.3.2 Bingham Plastic Model

The Bingham plastic model is defined by the graphical relationship shown in Figure 9.

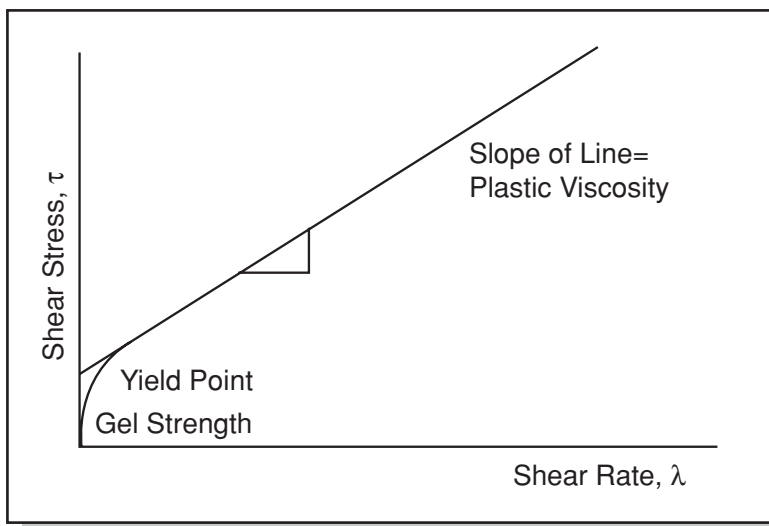

Figure 9 Shear Stress vs. Shear Rate Relationship for Bingham Plastic Fluids

The equation of this relationship can be expressed as:

$$\tau = \tau_y + \mu_p \dot{\gamma}$$

Equation 4 Shear Stress to Shear Rate Relationship for Bingham Plastic Fluids

Models which behave according to the Bingham plastic model will not flow until the applied shear stress, τ exceeds a certain minimum shear stress value known as the **yield point**, τ_y but after the yield point has been exceeded, changes in shear stress are directly proportional to changes in shear rate, with the constant of proportionality being called the **plastic viscosity**, μ_p . In reality the fluid will flow when the **gel strength** of the fluid has been exceeded. The yield point defined in the Bingham model is in fact an extrapolation of the linear relationship between stress and shear rate at medium to high shear rates and as such describes the dynamic yield of the fluid. The gel strength represents the shear stress to shear rate behaviour of the fluid at near zero shearing conditions. This model can be used to represent a Newtonian fluid when the yield strength is equal to zero ($\tau_y = 0$). In this case the plastic viscosity is equal to the Newtonian viscosity. The above equation is only valid for laminar flow.

3.3.3 Power Law Model

The power-law model is defined by the following mathematical model:

$$\tau = K\dot{\gamma}^n$$

Equation 5 Shear Stress to Shear Rate Relationship for Power Law Fluids

A graphical representation of this model is shown in Figure 10. Like the Bingham plastic fluid, the power-law fluid requires two parameters for its characterisation. However, the power-law model can be used to represent a pseudoplastic fluid ($n < 1$), a Newtonian fluid ($n = 1$), or a dilatant fluid ($n > 1$). The above is only valid for laminar flow.

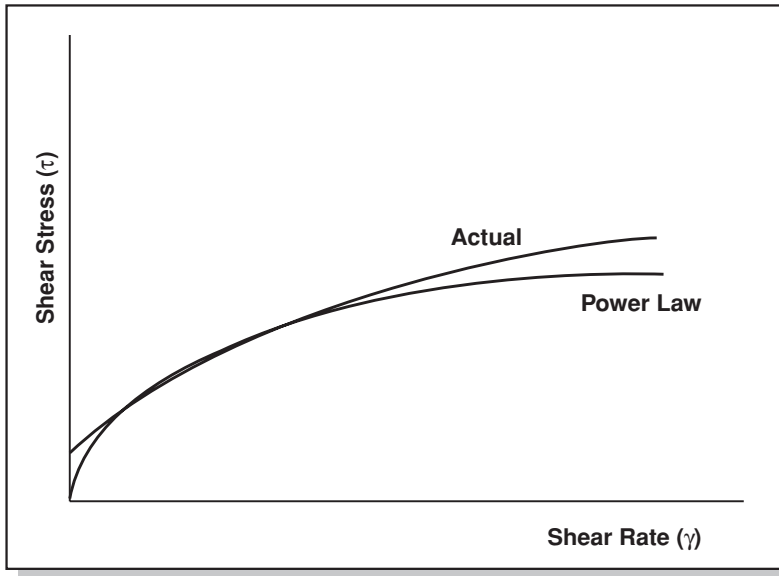

Figure 10 Shear Stress vs. Shear Rate Relationship for Power Law Fluids

This model is the best approximation for the behaviour of Polymer based fluids. The parameter K is usually called the consistency index of the fluid, and the parameter n is usually called either the power-law exponent or the non-Newtonian index. The deviation of the dimensionless flow-behaviour index from unity characterises the degree to which the fluid behaviour is non-Newtonian.

Parameter	c.g.s Units	Field Units
Viscosity	1 poise (100 cp, 1 dyne-s/cm ² , 1 g/cm.s)	1/479 lbf-s/sq ft.
Yield Point	1 dyne/cm ²	1/4.79 lbf/100 sq. ft.
Consistency Index, K	1 dyne-s ⁿ /cm ² (1 g/cm.s ²⁻ⁿ)	1/479 lbf-s ⁿ /sq.ft.

Table 1 Rheological Parameters and Units

4. FRICTIONAL PRESSURE DROP IN PIPES AND ANNULI

When attempting to quantify the pressure losses inside the drillstring and in the annulus it is worth considering the following matrix:

Fluid Type	Laminar Flow		Turbulent Flow	
	Pipe	Annulus	Pipe	Annulus
Newtonian	?	?	?	?
Bingham Plastic	?	?	?	?
Power law	?	?	?	?

An equation will be required to describe each of the elements in the above matrix. The following section of this chapter will therefore present the equations which have been developed for each of these set of conditions.

4.1 Laminar Flow in Pipes and Annuli

The flow regime within which the fluid is flowing in a pipe or annulus will depend on the Reynolds number for the system in question. The Reynolds number for each part of the system will however be different and it is possible for the fluid in one part of the system to be in laminar flow and the other in turbulent flow. Hence the fluid may be in laminar flow in the drillpipe but in turbulent flow in the drillcollars. The equations which describe the pressure losses when the fluid is in laminar flow can be derived theoretically. The following assumptions must however be made when developing these equations:

- The drillstring is placed concentrically in the casing or open hole
- The drillstring is not being rotated
- Sections of open hole are circular in shape and of known diameter
- The drilling fluid is incompressible
- The flow is isothermal

In reality, none of these assumptions are completely valid, and the resulting system of equations will not describe the laminar flow of drilling fluids in the well perfectly. Some research has been conducted on the effect of pipe eccentricity, pipe rotation, and temperature and pressure variations on flowing pressure gradients but the additional computational complexity required to remove the assumptions listed above is seldom justified in practice.

Fluid flowing in a pipe or a concentric annulus does not have a uniform velocity. If the flow pattern is laminar, the fluid velocity immediately adjacent to the pipe walls will be zero, and the fluid velocity in the region most distant from the pipe walls will be maximum. Typical flow velocity profiles for a laminar flow pattern are shown in Figure 11.

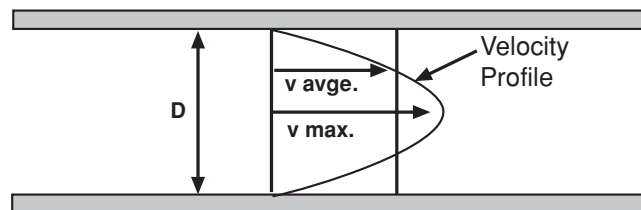

Figure 11 Laminar Flow Profiles in Pipes

4.1.1 Newtonian Fluids

An analytical expression for the isothermal, laminar flow of **Newtonian fluids** in pipes can be derived by using force balance principles. This equation is commonly known as the **Hagen-Poiseuille equation**:



$$P = \frac{32\mu\bar{v}L}{d^2}$$

Equation 6 Hagen-Poiseuille equation.

Converting to field units we have the equation for the pressure loss ifor the flow of a **Newtonian Fluid in a pipe**

$$\frac{dP}{dL} = \frac{\mu\bar{v}}{1,500d^2}$$

Equation 7 Newtonian Flow in Pipes

and with some mathematical manipulation an equation for the flow of **Newtonian Fluid in an annulus** can be derived:

$$\frac{dP}{dL} = 1500 \left[\frac{\mu\bar{v}}{d_2^2 + d_1^2 - \frac{d_2^2 - d_1^2}{\ln \frac{d_2}{d_1}}} \right]$$

Equation 8 Newtonian Flow in Annuli

Both of the above equations are expressed in field units.

4.1.2 Bingham Plastic Fluids

Analytical expressions for the isothermal, laminar flow of Non-Newtonian fluids can be derived by following essentially the same steps used for Newtonian fluids. The equation for the frictional pressure loss in a **pipe** whilst circulating a **Bingham Plastic Fluid** is given by :

$$\frac{dP}{dL} = \frac{\mu_p\bar{v}}{1,500d^2} + \frac{\tau_y}{225d}$$

Equation 9 Bingham Plastic Flow in Pipes

The equation for the frictional pressure loss in an **annulus** whilst circulating a **Bingham Plastic Fluid** is given by :

$$\frac{dP}{dL} = \frac{\mu_p \bar{v}}{1000(d_2-d_1)^2} + \frac{\tau_y}{200(d_2-d_1)}$$

Equation 10 Bingham Plastic Flow in Annuli

Both of the above equations are expressed in field units.

4.1.3 Power Law Fluid

As in the case of the Bingham Plastic Fluid the development of expressions for the pressure loss in pipes and annuli when circulating Power law Fluids is similar to that for a Newtonian fluid. The equation for the frictional pressure loss in a **pipe** whilst circulating a **Power law Fluid** is given by :

$$\frac{dP}{dL} = \frac{k\bar{v}}{144,000d^{(1+n)}} \left(\frac{3+1/n}{0.0416} \right)^n$$

Equation 11 Power Law Flow in Pipes

The equation for the frictional pressure loss in an **annulus** whilst circulating a **Power law Fluid** is given by :

$$\frac{dP}{dL} = \frac{k\bar{v}}{144,000d(d_2-d_1)^{(1+n)}} \left(\frac{2+1/n}{0.0208} \right)^n$$

Equation 12 Power Law Flow in Annuli

Once again both of the above equations are expressed in field units.

EXERCISE 2 Pressure loss in Laminar Flow

- Calculate the velocity of a fluid flowing through a 5" 19.5 lb/ft drillpipe (I.D.= 4.276") at 150 gpm.
- Determine the pressure loss in the above situation if the fluid is a Bingham Plastic fluid with a plastic viscosity of 20 cp, a yield point of 15 lb/100 sq. ft and density is 10 ppg.
- Calculate the pressure loss in the above situation if the fluid was a Power Law fluid with a non-Newtonian Index of 0.75 and a consistency index of 70 eq cp

4.2 Turbulent Flow

When the drilling fluid is pumped at a high rate the fluid laminae become unstable and break into a chaotic, diffused flow pattern. The fluid is then in turbulent flow. The transfer of momentum caused by this chaotic fluid movement causes the velocity distribution to become more uniform across the centre portion of the conduit than for laminar flow. However, a thin boundary layer of fluid near the pipe walls generally remains in laminar flow. A schematic representation of turbulent pipe flow is shown in Figure 12.

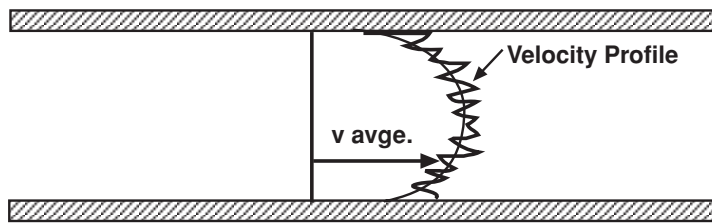

Figure 12 Turbulent Flow Profile In Pipes

A mathematical development of flow equations for turbulent flow has not been possible to date. However, a large amount of experimental work has been done in straight sections of circular pipe and annuli, and the factors influencing the onset of turbulence and the frictional pressure losses due to turbulent flow have been identified.

4.2.1 Determination of Laminar/Turbulent Boundary in a Non Newtonian Fluids

An accurate turbulence criteria, in other words the point at which the flow theoretically changes from Laminar to Turbulent flow, is required for non-Newtonian fluids. In the case of Newtonian fluids this determination is based on the Reynolds number. However, since there is no **single** parameter that defines the rheological properties of a Non-Newtonian fluid, such as the Newtonian viscosity, we have to establish an apparent Newtonian viscosity for the Non - Newtonian fluid. The second problem is that in the case of of annular flow there is no single value for pipe diameter in the above equation.

4.2.2 Turbulent Flow of Newtonian Fluids in Pipes

The equation for the pressure losses in turbulent flow of a Newtonian fluid in a pipe is derived from incorporating a control factor in the pressure loss equation:

$$\frac{dP}{dL} = 4f \frac{\rho \bar{v}^2}{2d}$$

Equation 13 Fanning Equation for Pressure Loss

This equation is known as the Fanning Equation and the friction factor, f defined by this equation is called the **Fanning friction factor**. All of the terms in this

equation, except for the friction factor, can be determined from the operating parameters. The friction factor, f is a function of the Reynolds Number N_{Re} and a term called the relative roughness, e/d . The relative roughness is defined as the ratio of absolute roughness, e , to the pipe diameter where the absolute roughness represents the average depth of pipe-wall irregularities. A plot of friction factor against Reynolds number on log-log paper is called a **Fanning chart** (Figure 13).

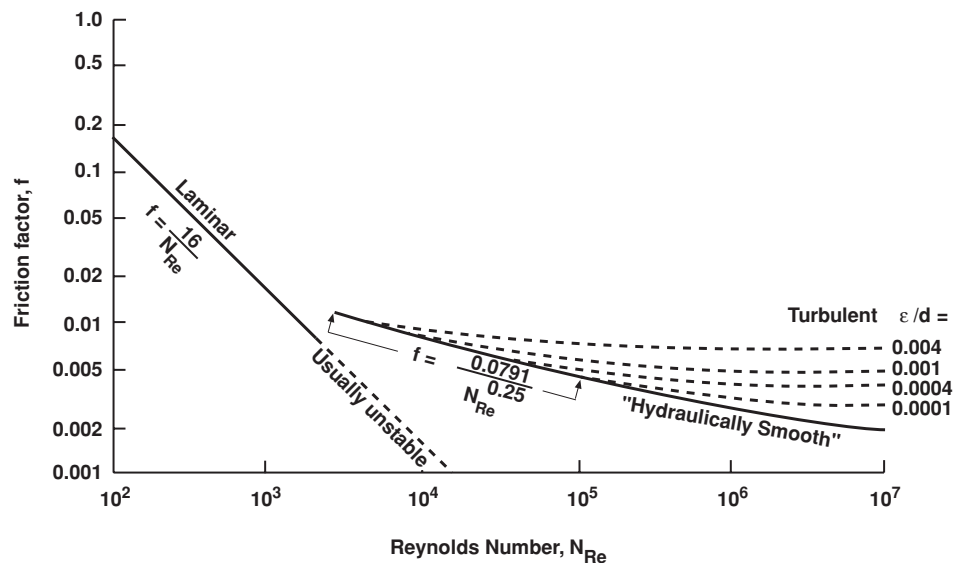

Figure 13 Fanning Chart for Friction Factors for Turbulent Flow in Turbulent Flow in Circular Pipes

An empirical correlation for the determination of friction factors for fully developed turbulent flow in circular pipe has been presented by Colebrook. The **Colebrook function** is given by:

$$\frac{1}{\sqrt{f}} = 4 \log \left(0.269 \frac{\epsilon}{d} + \frac{1.255}{N_{Re} \sqrt{f}} \right)$$

Equation 14 Colebrook Function

The friction factor, f appears both inside and outside the log term of Colebrook's equation and therefore an iterative technique is required to solve the equation. This difficulty can be avoided by using the graphical representation of the function in Figure 13.

For smooth pipe, the Colebrook equation reduces to:

$$\frac{1}{\sqrt{f}} = -4 \log \left(N_{Re} \sqrt{f} \right) - 0.395$$

Equation 15 Colebrook Approximation for smooth Pipe



Blasius presented a straight-line approximation (on a log-log plot) of the Colebrook function for smooth pipe and a Reynolds number range of 2,100 to 100,000. This approximation is given by:

$$f = \frac{0.0791}{N_{Re}^{0.25}}$$

Equation 16 Blasius modification of Colebrook Approximation

where $2,100 < N_{Re} < 100,000$ and $e/d = 0$.

In addition, the Fanning equation can be applied to laminar flow if the friction factor for the laminar region is defined by:

$$F = \frac{16}{N_{Re}}$$

Once it is possible to determine the value of f then the Fanning equation can be re-arranged for the calculation of frictional pressure drop due to turbulent flow in circular pipe. Re-arranging and converting to field units gives:

$$\frac{dP}{dL} = \frac{fp\bar{v}^2}{25.8d}$$

Equation 17 Pressure Loss in Turbulent Flow in Pipes

Using Equation 17, a simplified turbulent flow equation can be developed for **smooth pipe** and **moderate Reynolds numbers**:

$$\frac{dP}{dL} = \frac{\rho^{0.75} q^{1.75} \mu^{0.25}}{d^{4.75}}$$

Equation 18 Pressure Loss in Smooth Pipes and Moderate Numbers

The above equation is only valid for circular pipe where $e/d = 0$ and N_{Re} is between **2,100 and 100,000**. Equation 18 is in a form that readily identifies the relative importance of the various hydraulic parameters on turbulent frictional pressure loss. For example, it can be shown that changing from 4.5in. to 5in. drillpipe would reduce the pressure loss in the drillpipe by about a factor of two.

4.2.3 Extension of Pipe Flow Equations to Annular Geometry

A large amount of experimental work relating flowrate to pressure losses has been conducted in circular pipes. Unfortunately however, very little experimental work

has been conducted in flow conduits of other shapes, such as annular geometries. When noncircular flow conduits are encountered, a common practice is to calculate an ‘effective circular diameter’ such that the flow behaviour in a circular pipe of that diameter would be roughly equivalent to the flow behaviour in the noncircular conduit. This effective diameter can be used in the Reynolds number and other flow equations to represent the size of the conduit. One criterion often used in determining an equivalent circular diameter for a noncircular conduit is the ratio of the cross-sectional area to the wetted perimeter of the flow channel. This ratio is called the **hydraulic radius**. For the case of an annulus, the hydraulic radius is given by:

$$r_H = \frac{d_2 - d_1}{4}$$

Equation 19 Hydraulic Radius

The equivalent circular diameter is equal to four times the hydraulic radius.

$$d_e = 4 r_H = d_2 - d_1$$

Equation 20 Equivalent Circular Diameter

Note that for $d_1 = 0$ (no inner pipe) the equivalent diameter correctly reduces to the diameter of the outer pipe.

A second criterion used to obtain an equivalent circular radius is the geometry term in the pressure-loss equation for laminar flow. Consider the pressure loss equations for pipe flow and concentric annular flow of Newtonian fluids given in Equations 7 and 8. Comparing the geometry terms in these two equations yields:

$$d_e = \sqrt{d_2^2 + d_1^2 - \frac{d_2^2 - d_1^2}{\ln(d_2/d_1)}}$$

Equation 21 Equivalent Circular Diameter 2

A third expression for the equivalent diameter of an annulus can be obtained by comparing the equation for pressure loss in slot flow :

$$d_e = 0.816 (d_2 - d_1)$$

Equation 22 Equivalent Circular Diameter 3

For most annular geometries encountered in drilling operations, $d_1/d_2 > 0.3$, and Equations 21 and 22 give almost identical results.



All three expressions for equivalent diameter shown above have been used in practice to represent annular flow. Equation 20 is probably the most widely used in the petroleum industry. However, this is probably due to the simplicity of the method rather than a superior accuracy.

4.2.4 Turbulent Flow of Bingham Plastic Fluids in Pipes and Annuli

The frictional pressure loss associated with the turbulent flow of a Bingham plastic fluid is affected primarily by density and plastic viscosity. Whilst the yield point of the fluid affects the frictional pressure loss in laminar flow, in fully turbulent flow the yield point is no longer a highly significant parameter. It has been found empirically that the frictional pressure loss associated with the turbulent flow of a Bingham plastic fluid can be predicted using the equations developed for Newtonian fluids. The plastic viscosity is simply substituted for the Newtonian viscosity. This substitution can also be made in the Reynolds number used in the Colebrook function defined by Equation 14 or in the simplified turbulent flow equation given by Equation 18.

These equations are however only appropriate when the flow is in turbulence. There must therefore be an equation which can be used to determine the point at which the flow enters turbulence. The obvious solution is to use a modified form of the Reynolds number. There are two problems associated with using the Reynolds number criterion. The first is that this criterion was designed for pipe flow and an equivalent diameter must be used if the fluid is flowing in an annulus. The second problem is that non-Newtonian fluids such as Bingham Plastic fluids do not have a single parameter representation of viscosity. In the case of Bingham Plastic fluids a representative apparent viscosity is developed. The apparent viscosity most often used is obtained by comparing the laminar flow equations for Newtonian and Bingham plastic fluids. For example, combining the pipe flow equation for the Newtonian and Bingham plastic model yields an equation for μ_a , the apparent Newtonian viscosity:

$$\mu_e = \mu_p + \frac{6.66\tau_y d}{\bar{v}}$$

Equation 23 Apparent Newtonian Viscosity for Bingham Fluid in Pipes

A similar comparison of the laminar flow equations for Newtonian and Bingham fluids in an annulus yields:

$$\mu_e = \mu_p + \frac{5\tau(d_2 - d_1)}{v}$$

Equation 24 Apparent Newtonian Viscosity for Bingham Fluid in Annuli

These apparent viscosities can be used in place of the Newtonian viscosity in the Reynolds number formula. As in the case of Newtonian fluids, a Reynolds number greater than 2,100 is taken as an indication that the flow pattern is turbulent.

4.2.5 Turbulent Flow of Power Law Fluids in Pipes and Annuli

Dodge and Metzner have published a turbulent flow correlation for fluids that follow the power-law model. Their correlation has gained widespread acceptance in the petroleum industry. As in the case of Bingham Plastic fluids, an apparent viscosity for use in the Reynolds number criterion is obtained by comparing the laminar flow equations for Newtonian and power-law fluids. For example, combining the Newtonian and power-law equations for laminar flow yields an equation for μ_a , the apparent

Newtonian viscosity:

$$\mu_a = \frac{Kd^{(1-n)}}{96\bar{v}^{(1-n)}} \left(\frac{3 + 1/n}{0.0416} \right)^n$$

Equation 25 Apparent Newtonian Viscosity for Power Law Fluid in Pipes

Substituting the apparent viscosity in the Reynolds number equation gives:

$$N_{Re} = \frac{89,100\rho\bar{v}^{(2-n)}}{k} \left(\frac{0.0416d}{3 + 1/n} \right)$$

Equation 26 Reynolds Number for Power Law Fluid in Pipes

As in the case of the Bingham plastic model, the use of the apparent viscosity concept in the calculation of Reynolds number does not yield accurate friction factors when used with the Colebrook function. However, Dodge and Metzner developed a new empirical friction factor correlation for use with the Reynolds number given by Equation 26. The friction factor correlation is given by:

$$\sqrt{1/f} = \frac{4.0}{n^{0.75}} \log (N_{Re} f^{1-n/2}) - \frac{0.395}{n^{1.2}}$$

Equation 27 Friction Factor Correlation for for Power Law Fluids

The correlation was developed only for smooth pipe. However, this is not a severe limitation for most drilling fluid applications. A graphical representation of Equation 27 is shown in Figure 14. The upper line on this graph is for $n=1$ and is identical to the smooth pipeline on Figure 13.

The critical Reynolds number, above which the flow pattern is turbulent, is a function of the flow-behaviour index n . It is recommended that the critical Reynolds number for a given n value be taken from Figure 14 as the starting point of the turbulent flow line for the given n value. For example, the critical Reynolds number for an n value of 0.2 is 4,200.

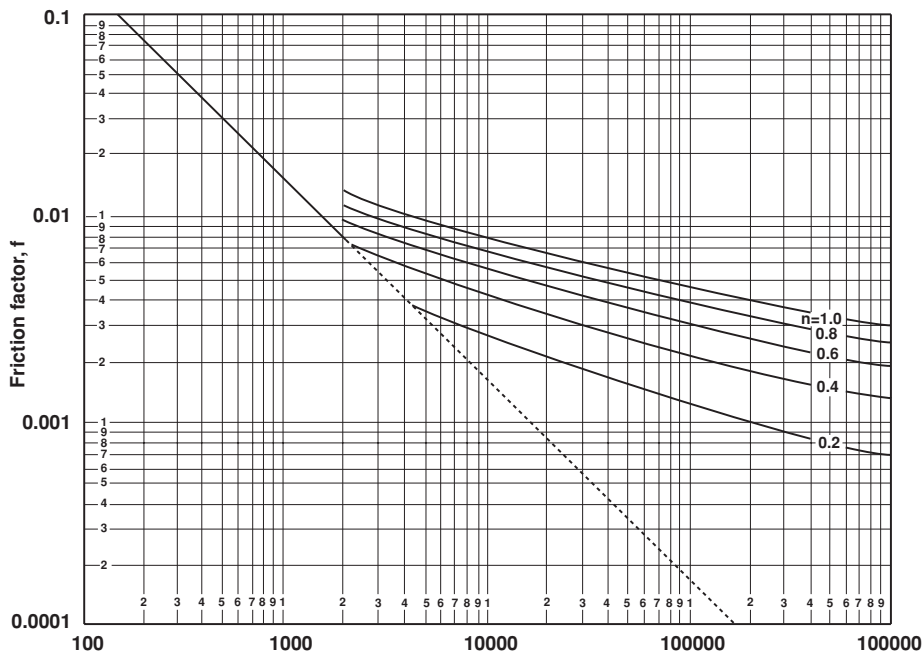

Figure 14 Friction Factors for Flow of Power Law Fluids in Circular Pipes

The Dodge and Metzner correlation can be applied to annular flow by the development of an apparent viscosity from a comparison of the laminar annular flow equations for Newtonian and power-law fluids :

$$\begin{aligned} & \frac{\mu \bar{v}}{1,000 (d_2 - d_1)^2} \\ = & \frac{K \bar{v}^n}{144,000 (d_2 - d_1)^{1+n}} \left(\frac{2 + 1/n}{0.0208} \right)^n \end{aligned}$$

Equation 28 Apparent Newtonian Viscosity for Power Law Fluid in Annuli

Solving for μ_a , the apparent Newtonian viscosity gives:

$$\mu_a = \frac{K(d_2 - d_1)^{(1-n)}}{144 \bar{v}^{(1-n)}} \left(\frac{2 + 1/n}{0.0208} \right)^n$$

Equation 29 Apparent Newtonian Viscosity for Power Law Fluid in Annuli

Substituting this apparent viscosity in Reynolds number equation and using Equation 23 for equivalent diameter gives:

$$N_{Re} = \frac{109,000\rho\bar{v}^{(2-n)}}{\left[\frac{d_2-d_1}{n}\right]^n}$$

Equation 30 Reynolds Number for Power Law Flow in Annuli

5. FRICTIONAL PRESSURE DROP ACROSS THE BIT

A schematic of incompressible flow through a short constriction, such as a bit nozzle, is shown in Figure 15. In practice, it is generally assumed that:

1. the change in pressure due to a change in elevation is negligible.
2. the velocity v_o upstream of the nozzle is negligible, compared with the nozzle velocity v_n
3. the frictional pressure loss across the nozzle is negligible.

The pressure loss across a nozzle is given by:

$$P_1 - 8.074 \times 10^{-4} \rho v_n^2 = P_2$$

Equation 31 Pressure below a nozzle

In field units of psi, ppg, fps and ft and substituting the symbol ΔP_b for the pressure drop ($P_1 - P_2$) and solving this equation for the nozzle velocity v_n yields:

$$v_n = \sqrt{\frac{\Delta P_b}{8.074 \times 10^{-4} \rho}}$$

Equation 32 Theoretical Nozzle Velocity

where,

- ΔP_b = Pressure Loss across the nozzle (psi)
- ρ = Density of the Fluid (ppg)
- v_n = velocity of discharge (feet per second)

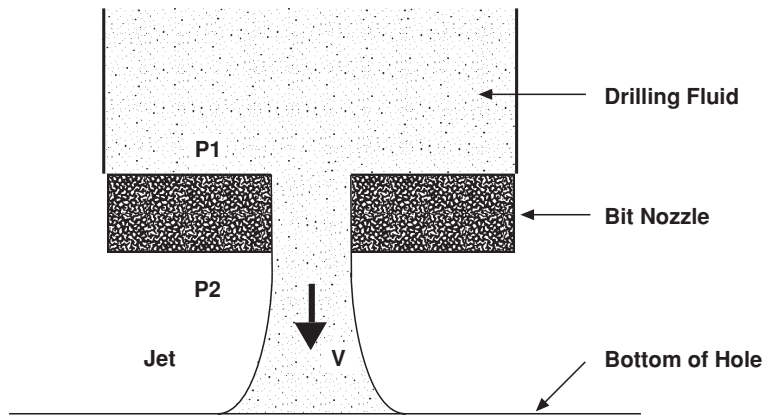

Figure 15 Discharge Through a Nozzle

The exit velocity predicted by Equation 32 for a given pressure drop across the bit, ΔP_b , is never realised. The actual velocity is always smaller than the velocity computed using Equation 32 primarily because the assumption of frictionless flow is not strictly true. To compensate for this difference, a correction factor or discharge coefficient C_d is usually introduced so that the modified equation:

$$v_n = C_d \sqrt{\frac{\Delta P_b}{8.074 \times 10^{-4} \rho}}$$

Equation 33 Nozzle Velocity including Coefficient of Discharge

will result in the observed value for nozzle velocity. The discharge coefficient may be as high as 0.98 but the recommended value is 0.95.

A rock bit has more than one nozzle, usually having the same number of nozzles as cones. When more than one nozzle is present, the pressure drop applied across all of the nozzles must be the same. If the pressure drop is the same for each nozzle, the velocities through all nozzles are equal. In field units, the nozzle velocity, v_n is given by:

$$v_n = \frac{q}{3.117 A_t}$$

Equation 34 Total Velocity through Nozzles

where v_n has units of feet per second, q has units of gallons per minute, and A_t has units of square inches. Combining Equations 33 and 34 and solving for the pressure drop across the bit, ΔP_b yields:

$$\Delta P_b = \frac{8.311 \times 10^{-5} \rho q^2}{C_d^2 A_t^2}$$

Equation 35 Total Pressure Drop Across Nozzles

Since the viscous frictional effects are essentially negligible for flow through short nozzles, Equation 35 is valid for both Newtonian and non-Newtonian liquids.

Bit nozzle diameters are often expressed in 32nds of an inch. For example, if the bit nozzles are described as “12-13-13” this denotes that the bit contains one nozzle having a diameter of $12/32$ in. and two nozzles having a diameter of $13/32$ in.

6. OPTIMISING THE HYDRAULICS OF THE CIRCULATING SYSTEM

6.1 Designing for Optimum Hydraulics

The two major aims of an optimum hydraulics programme are:

- To clean the hole effectively
- To make best use of power available to drill the hole.

To achieve the first aim the hydraulics must be designed so that the annular velocity never falls below a pre-determined minimum for lifting cuttings (say 130 ft/min). The second aim is attainable by ensuring that the optimum pressure drop occurs across the bit. Since this pressure drop will depend on circulation rate some careful designing is required to satisfy both objectives.

There are two different approaches to optimum hydraulics design:

- a. Maximise the Hydraulic Horsepower at the Bit

This assumes that the best method of cleaning the hole is to concentrate as much fluid energy as possible at the bit.

- b. Maximise the Hydraulic Impact at the Bit

This assumes that the most effective method is to maximise the force with which the fluid hits the bottom of the hole.

The more popular approach is to maximise the hydraulic horsepower at the bit and this will be dealt with in more detail.

a. Maximising Hydraulic Horsepower

The source of all hydraulic power is the pump input from the mudpumps. The hydraulic horsepower at the pump is therefore given by:

$$HHP_t = \text{input HP} \times E_m$$

Equation 36 Hydraulic Horsepower at the Bit



where ,

E_m = mechanical efficiency

The hydraulic horsepower at the bit (HHP_b) can be written as:

$$HHP_b = HHP_t - HHP_s$$

where,

HHP_t = total hydraulic horsepower available from the pump

HHP_s = hydraulic horsepower expended in the circulation system (excluding the bit)

HHP_t can be related to the discharge pressure and flow rate:

$$HHP_t = \frac{P_t Q}{1714}$$

Equation 37 Total Hydraulic Horsepower

where,

P_t = total discharge pressure (psi)

Q = flow rate (gpm)

Similarly:

$$HHP_s = \frac{P_s Q}{1714}$$

Equation 38 Sacrificial Hydraulic Horsepower

where,

P_s = pressure drop in system (excluding the bit)

Therefore Equation 36 can be rewritten as:

$$HHP_b = \frac{P_t Q}{1714} - \frac{P_s Q}{1714}$$

Equation 39 Hydraulic Horsepower at the Bit

An empirical relationship between P and Q in turbulent flow gives:

$$P_s = kQ^n$$

Equation 40 Empirical Equation for Pressure Losses in the System $P_s = kQ^n$

where,

k and n = constants for the system (includes wellbore geometry, mud properties, etc)

Substituting for P_s in equation 39 yields:

$$\text{HHP}_b = \frac{P_t Q}{1714} - \frac{KQ^n Q}{1714}$$

$$\text{HHP}_b = \frac{P_t Q}{1714} - \frac{KQ^{(n+1)}}{1714}$$

Equation 41 Pressure Loss Across Bit When Horsepower at the Bit is Maximum or

Differentiating with respect to Q to find maximum HHP

$$\frac{d\text{HHP}_b}{dQ} = \frac{P_t}{1714} - \frac{(n+1)KQ^n}{1714}$$

The maxima and minima will occur when the above equals zero:

$$P_t = (n+1)kQ^n$$

$$P_t = (n+1)P_s$$

or

$$P_s = \frac{1}{(n+1)} P_t$$

$$P_b = P_t - P_s$$

or

$$P_b = \left[\frac{n}{(n+1)} \right] P_t$$

It is generally found in circulation rate tests that n is approximately equal to 1.85 and therefore for maximum HHP_b the optimum pressure drop at the bit (P_b) should be 65% of the total discharge pressure at the pump. This condition must be built into the hydraulics programme to achieve maximum efficiency.

Note that P_t remains constant throughout.

b. Maximising Hydraulic Impact

The purpose of the jet nozzles is to improve the cleaning action of the drilling fluid at the bottom of the hole. Before jet bits were introduced, rock chips were not removed efficiently and much of the bit life was consumed regrinding the rock fragments. While the cleaning action of the jet is not well understood, several investigators



have concluded that the cleaning action is maximized if the total hydraulic impact force is jetted against the hole bottom. If it is assumed that the jet stream impacts the bottom of the hole in the manner shown in Figure 15 all of the fluid momentum is transferred to the hole bottom. Since the fluid is travelling at a vertical velocity v_n before striking the hole bottom and is travelling at zero vertical velocity after striking the hole bottom, the time rate of change of momentum (in field units) is given by:

$$F_i = 0.000516 \times MW \times Q \times V_n$$

Equation 42 Impact force of fluid ejected from nozzle

where,

MW = mud weight (ppg)

Q = flow rate (gpm)

v_n = nozzle velocity (ft/s)

Maximising the impact force can be achieved by ensuring that $P_b = 0.49 P_t$
or $P_s = 0.51 P_t$

6.2 Pressure Losses in the Circulating System

In order to optimise the hydraulics of any system it is therefore essential that the pressure losses in that system are understood and can be quantified.

Since the returning mud at the flowline is at atmospheric pressure, the discharge pressure delivered by the pump has been totally dissipated throughout the system. The pressure drops may be denoted by:

- (i) P_{sc} - the pressure loss in the surface connections (e.g. standpipe, Kelly hose). This is generally small in comparison to other components (<100 psi).
- (ii) P_d - the pressure loss in the drillstring (i.e. inside the drillpipe and drill collars).
- (iii) P_b - the pressure loss through the bit nozzles. This is where most of the pressure drop should occur for efficient drilling
- (iv) P_a - the pressure drop in the annulus.

The total pressure drop (P_t) can be written:

$$P_t = P_{sc} + P_d + P_b + P_a \text{ or}$$

$$P_t = P_b + P_s$$

where P_s = pressure loss in the system ($P_s = P_{sc} + P_d + P_a$). The system pressure loss

(parasitic loss) must be controlled so that most of the total pressure delivered by the pump is used across the bit. All of these losses can be quantified using Sections 4 and 5 of this set of notes.

Generally, laminar flow occurs in the annulus, while turbulent flow occurs in the drill string. Turbulent flow is generally avoided in the annulus since it may cause washouts in the formation by erosion.

6.3 Graphical Method for Optimization of Hydraulics Programme

Given that the power and pressure limitations of the system the geometry of the circulating system and the fluid properties are to a great extent fixed, the only control that an engineer has over the optimization process is to select the pump rate and nozzles for the bit. The following method may be used to determine the optimum nozzle configuration and pumping rates. These calculations would be performed on the rigsite with information gathered just before pulling one bit from the hole and prior to running the next bit in hole.

1. Determine and draw the following lines on a log/log chart of Pressure vs. flowrate.

- a) Maximum flowrate, Q_{\max} (i.e. critical velocity).
- b) Minimum flowrate, Q_{\min} (i.e. slip velocity).
- c) Maximum allowable surface pressure, P_{\max}

Note :

1. the critical velocity is the velocity below which the fluid in the annulus is in laminar flow.
 2. the slip velocity is the velocity below which the cuttings will settle onto and form a bed on the low side wall of the wellbore.
2. Record pump-pressures (P_{surf}) for three different pump rates, just before pulling the bit.
3. Calculate the bit pressure loss (P_{bit}) for each pumprate.

$$P_{\text{bit}} = \frac{\rho \times Q^2}{564 A_n^2}$$

where,

- | | | |
|------------------|---|--|
| P_{bit} | = | pressure loss across the bit, psi |
| ρ | = | density of the mud, psi/ft |
| Q | = | flowrate, gpm |
| A_n | = | Total flow area through the bit, in ² |

4. Calculate the pressure loss through the circulating system (P_{circ}) for each flowrate

$$P_{\text{circ}} = P_{\text{surf}} - P_{\text{bit}}$$



5. Plot P_{circ} vs. Q on the log/log chart and draw a line between the points.
6. Measure the slope (n) of the line. Determine the value of W from Table 1
7. Calculate the optimum circulating system pressure loss ($P_{\text{circ.opt}}$).

$$P_{\text{circ.opt}} = W \times P_{\text{max}}$$

Note : W is a factor dependant on the value of the exponent 'n' in the empirical equation relating flowrate to pressure loss in the circulating system.

8. The intersection of $P_{\text{circ.opt}}$ with the P_{circ} line on the chart specifies the optimum flowrate (Q_{opt}).
9. Calculate optimum nozzle area :

$$\text{Nozzle area} = \frac{Q_{\text{opt}}}{23.75} \sqrt{\frac{\rho}{P_{\text{max}} - P_{\text{circ.opt}}}}$$

10. Obtain optimum nozzle sizes for next bit run from Table 2.

n	2.0	1.9	1.8	1.7	1.6	1.5	1.4	1.3	1.2	1.1	1.0
W IF	0.50	0.51	0.53	0.54	0.56	0.57	0.59	0.61	0.60	0.65	0.67
W HHP	0.33	0.34	0.36	0.37	0.38	0.40	0.42	0.43	0.45	0.48	0.50

Table 1 Circulating System Factor

NOZZLE SIZE	NOZZLE AREA (in. ²)
18-18-18	0.75
18-19-17	0.72
18-17-17	0.69
17-17-17	0.67
17-17-16	0.64
17-16-16	0.61
16-16-16	0.59
16-16-15	0.57
16-15-15	0.54
15-15-15	0.52
15-15-14	0.50
15-14-14	0.47
14-14-14	0.45
14-14-13	0.43
14-13-13	0.41
13-13-13	0.39
13-13-12	0.37
13-12-12	0.35
12-12-12	0.33
12-12-11	0.31
12-11-11	0.30
11-11-11	0.28
11-11-10	0.26
11-10-10	0.25
10-10-10	0.23
10-10-9	0.22
10-9-9	0.20
9-9-9	0.19
9-9-8	0.17
9-8-8	0.16

Table 2 Nozzle Area and sizes



EXERCISE 3 Hydraulics Optimisation

Whilst drilling the 12 1/4" hole section of NONAME1 at 8000 ft. the cost/ft of the bit run was found to have reached its minima and to be increasing. It was therefore decided to pull the bit and run another bit. Determine the mozzle configuration that will optimise the hydraulic horsepower at the bit in the next bit run.

To assist in the selection of the nozzle configuration which will optimise the hydraulic horsepower at the bit the following circulation rate test was performed :

Pump Rate SPM	Circulating Pressure psi
120	3005
105	2242
90	1852
80	1363

The test was conducted with 3 x 14 nozzles in the bit and 6 1/2" liners in the pumps

All other relevant information was also compiled :

Minimum Annular Velocity 110 ft/min.

Mud Density :

10 ppg

Pump Data :

Type	National Triplex 12-P-160T
HP	1600
Max. SPM	120
Stroke	12"
Liner Size	5 3/4", 6 1/2", 7"
E_v	0.95
E_m	0.90

Drillstring data :

Drillpipe 5" 19.5 lb/ft

Solutions to Exercises

Exercise 1 Determination of Fluid Flow Regime:

a. The flow regime will be determined from the Reynolds number equation:

$$N_{Re} = \frac{928\rho\bar{v}d}{\mu}$$

$$N_{Re} = \frac{928 \times 10 \times v \times 4.276}{20}$$

$$= 1984 \times v$$

and since , $v = \frac{Q \text{ (gpm)}}{2.448 \times d^2}$ ft/sec.

$$= \frac{400}{2.448 \times 4.276^2} = 8.937 \text{ ft/sec.}$$

Therefore, $N_{Re} = 1984 \times 8.937$

$$= 17725 \quad \text{The fluid is therefore in Turbulent Flow}$$

b. The maximum flowrate to ensure laminar flow would require that the Reynolds number was less than 2100. Hence,

$$2100 = \frac{928 \times 10 \times v \times 4.276}{20}$$

Max. Velo. $v = 1.06 \text{ ft/sec}$

$$1.06 = \frac{Q}{2.448 \times 4.276^2}$$

Therefore,

Maximum Flowrate, $Q = 47.5 \text{ gpm}$



Exercise 2 Pressure loss in Laminar Flow

a. The velocity of a fluid flowing through a 5" 19.5 lb/ft drillpipe (I.D. = 4.276") at 150 gpm is:

$$v = \frac{Q \text{ (gpm)}}{2.448 \times d^2} \text{ ft/sec.}$$

$$= \frac{150}{2.448 \times 4.276^2} = 3.35 \text{ ft/sec.}$$

b. If the fluid in the above situation is a Bingham Plastic fluid with a plastic viscosity of 20 cp, a yield point of 15 lb/100 sq. ft and density is 10 ppg the pressure loss in the pipe will be:

$$\frac{dP}{dL} = \frac{\mu_p \bar{v}}{1,500d^2} + \frac{\tau_y}{225d}$$

$$\frac{dp}{dl} = \frac{20 \times 3.35}{1500 \times 4.276^2} + \frac{15}{225 \times 4.276}$$

$$= 0.018 \text{ psi/ft}$$

$$= 18 \text{ psi per 1000 ft}$$

c. The pressure loss in the above situation if the fluid was a Power Law fluid with an non-Newtonian Index of 0.75 and a consistency index of 70 eq cp would be:

$$\frac{dP}{dL} = \frac{k\bar{v}}{144,000d^{(1+n)}} \left(\frac{3+1/n}{0.0416} \right)^n$$

$$\frac{dp}{dl} = \frac{70 \times 3.35}{144000 \times 4.276^{(1.75)}} \left[\frac{3 + 1/0.75}{0.0416} \right]^{0.75}$$

$$= 0.0042 \text{ psi/ft}$$

$$= 4.2 \text{ psi per 1000 ft}$$

Exercise 3 Hydraulics Optimisation

1. a. Calculate Maximum Flowrate
- b. Determine Minimum Flowrate
- c. Calculate Maximum Surface Pressure

a. Calculate the maximum volume output by each liner size and therefore the maximum flowrate:

$$Q = \frac{d^2 L x E_v x R}{98.03}$$

$$\begin{aligned} d &= 5 \frac{3}{4}'' , 6 \frac{1}{2}'' , 7'' \\ l &= 12'' \\ E_v &= 0.95 \\ R &= 120 \text{ spm} \end{aligned}$$

d in.	Q gpm	P _{max.} psi	Ann. Velocity ft/min.
5 3/4"	461	5354	90
6 1/2"	590	4183	116
7"	684	3614	134

Note : Pmax. is calculated on the basis of :

$$\text{HHPt} \times E_m = \frac{P_t \times Q}{1714}$$

Note: Ann. Velo. is based on 5" d.p. in 12 1/4" hole (+/- 5.1 gal./ft.)

b. The minimum annular velocity will be that required to ensure that the cuttings are removed from the hole. A typical value would be 110 ft/min. The 6 1/2" liner would therefore be selected and the maximum flowrate would be 590 gpm.

c. As shown above the maximum surface pressure would be 4183 psi at 590 gpm.

2. The pump pressures for four different pump rates were recorded prior to pulling the previous bit from the hole. They were as follows :

Pump Rate SPM	Surface Pressure psi
120	3005
105	2242
90	1852
80	1363



the bit pressure losses can be calculated from the following :

$$P_{\text{bit}} = \frac{\rho \times Q^2}{564 A_n^2}$$

where,

$$\rho = 0.52 \text{ psi/ft}$$

$$A_n = 0.45 \text{ in}^2$$

Flowrate GPM	psi	P_{bit}
590	1585	
516	1212	
443	894	
393	703	

From the above tabulation the pressure losses in the circulation system can be determined :

Flowrate gpm	P_{surf}	P_{bit}	$P_{\text{circ.}}$
590	3005	1585	1420
516	2242	1212	1030
443	1852	894	958
393	1363	703	660

3. The flowrate is plotted against the circulating pressure loss on log-log paper (See Figure Solution 3) and the gradient of the line measured. The gradient of this line is approx. 1.85.

4. From Table 1 it can be seen that the circulating system factor W is 0.35.

5. Thus the optimum circulating pressure loss at this depth and with this system is

$$P_{\text{circ.opt}} = W \times P_{\text{max}}$$

$$P_{\text{circ.opt}} = 1464 \text{ psi}$$

6. If this line is plotted on the log-log plot the optimum flowrate can be deduced. The optimum flowrate is found to be 600 gpm.

7. The optimum nozzle area is selected on the basis of the following equation :

$$\text{Nozzle area} = \frac{Q_{\text{opt}}}{23.75} \sqrt{\frac{\rho}{P_{\text{max}} - P_{\text{circ.opt.}}}}$$

$$= 0.358 \text{ in}^2$$

and the optimum configuration can then be selected from Table 2 as being 13/32", 12/32", 12/32".

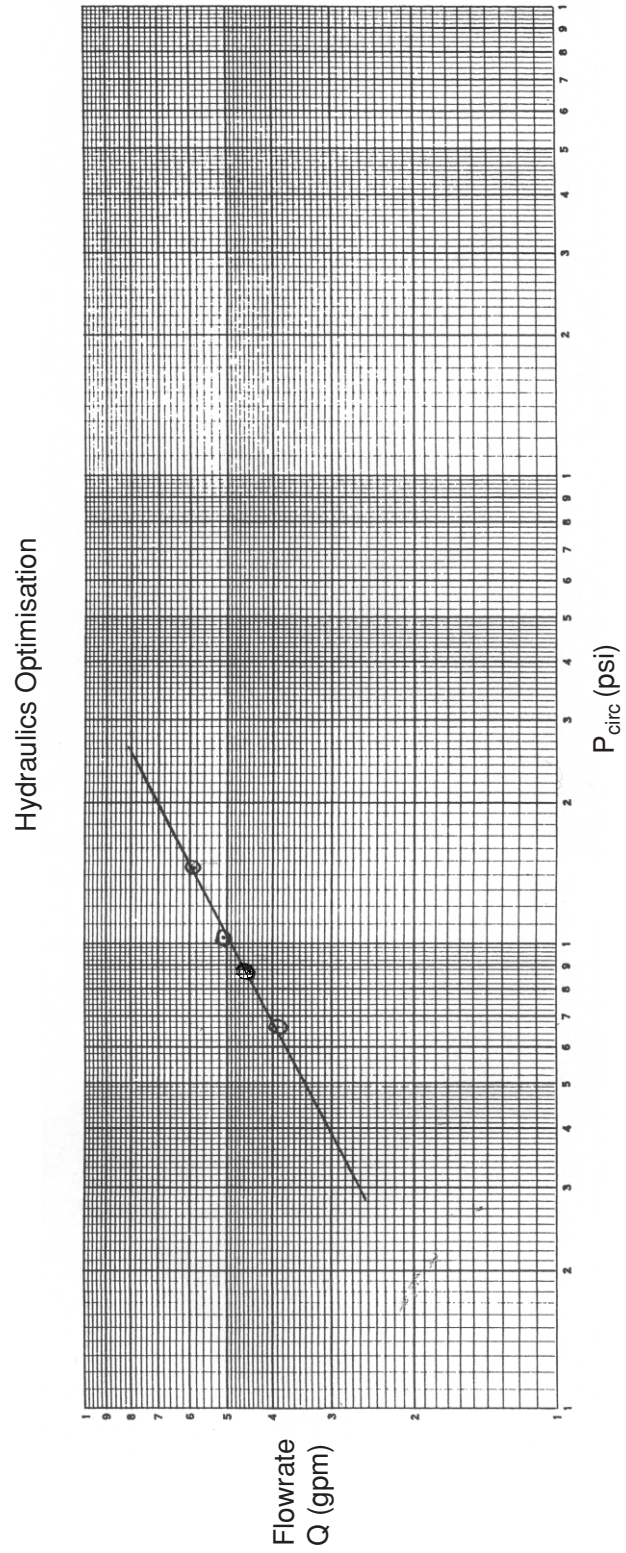

Directional Drilling *11*

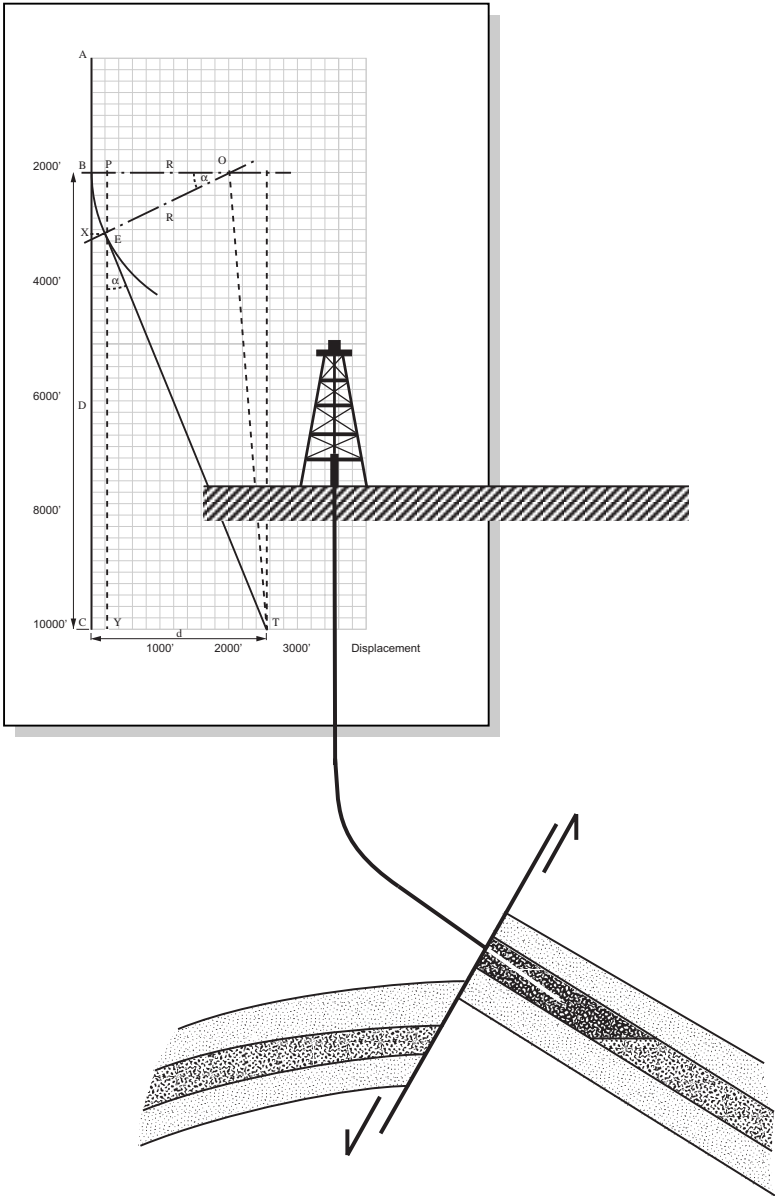

CONTENTS

1. INTRODUCTION

2. APPLICATIONS

3. DEPTH REFERENCE AND GEOGRAPHICAL REFERENCE SYSTEMS

- 3.1 Depth Reference Systems
- 3.2 Geographical Reference Systems

4. PLANNING THE PROFILE OF THE WELL

- 4.1 Parameters Defining the Wellpath
- 4.2 Defining the Points on the Wellpath
 - 4.2.1 Scaled Diagrams
 - 4.2.2 Geometrical Calculation Technique

5. CONSIDERATIONS WHEN PLANNING THE DIRECTIONAL WELL PATH

6. DEFLECTION TOOLS

- 6.1 Bent Sub and Mud Motor
- 6.2 Steerable Drilling Systems
 - 6.2.1 Components
 - 6.2.2 Dogleg Produced by a Steerable System
 - 6.2.3 Operation of a Steerable System
- 6.3 Rotary Steering System
 - 6.3.1 Downhole System
 - 6.3.2 Surface System
- 6.4 Directional Bottom Hole Assemblies (BHA)
 - 6.4.1 Packed Hole Assembly
 - 6.4.2 Pendulum Assembly
 - 6.4.3 Fulcrum Assembly
- 6.5 Whipstocks

APPENDIX - I : Positive Displacement Motors (PDM's) and Turbodrills

Solutions to Exercises





LEARNING OBJECTIVES:

Having worked through this chapter the student will be able to:

General:

- List and describe the applications of directional drilling techniques
- Describe the constraints on the trajectory of a deviated well.
- Define the terms: KOP; BUR; and tangent section of the well trajectory.

Trajectory Design:

- Calculate the: along hole depth, TVD and departure of the end of the build up section and the along hole depth of the bottom of the hole in a build and hold well profile.

Deflection Tools

- Describe the principles used in the deflection of a wellbore from a given trajectory.
- List and describe the tools used to initiate changes in wellbore trajectory.
- Describe the principles associated with the packed hole, pendulum and fulcrum BHA and when each would be used.
- Describe the component parts of a steerable drilling system and the mode of operation of such a system.
- Calculate the dogleg severity generated by a given BHA.

PDM's and Turbodrills:

- Describe the principles of operation of a PDM and Turbodrill.

1. INTRODUCTION

In the early days of land drilling most wells were drilled vertically, straight down into the reservoir. Although these wells were considered to be vertical, they rarely were. Some deviation in a wellbore will always occur, due to formation effects and bending of the drillstring. The first recorded instance of a well being deliberately drilled along a deviated course was in California in 1930. This well was drilled to exploit a reservoir which was beyond the shoreline underneath the Pacific Ocean. It had been the practise to build jetties out into the ocean and build the drilling rig on the jetty. However, this became prohibitively expensive and the technique of drilling deviated wells was developed. Since then many new techniques and special tools have been introduced to control the path of the wellbore.

An operating company usually hires a directional drilling service company to: provide expertise in planning the well; supply special tools; and to provide on-site assistance when operating the tools. The operator may also hire a surveying company to measure the inclination and direction of the well as drilling proceeds.

In this chapter we will discuss: the applications of directional well drilling; the design of these wells; and the techniques used to drill a well with controlled deviation from the vertical. The next chapter will discuss the tools and techniques used to survey the position of the well (determine the three dimensional position of all points in the wellbore relative to the wellhead).

2. APPLICATIONS

There are many reasons for drilling a non-vertical (**deviated**) well. Some typical applications of directionally controlled drilling are shown in Figure 1.

(a) Multi-well Platform Drilling

Multi-well Platform drilling is widely employed in the North Sea. The development of these fields is only economically feasible if it is possible to drill a large number of wells (up to 40 or 60) from one location (platform). The deviated wells are designed to intercept a reservoir over a wide areal extent. Many oilfields (both onshore and offshore) would not be economically feasible if not for this technique.

(b) Fault Drilling

If a well is drilled across a fault the casing can be damaged by fault slippage. The potential for damaging the casing can be minimised by drilling parallel to a fault and then changing the direction of the well to cross the fault into the target.

(c) Inaccessible Locations

Vertical access to a producing zone is often obstructed by some obstacle at surface (e.g. river estuary, mountain range, city). In this case the well may be directionally drilled into the target from a rig site some distance away from the point vertically above the required point of entry into the reservoir.

(d) Sidetracking and Straightening

It is in fact quite difficult to control the angle of inclination of any well (vertical or deviated) and it may be necessary to ‘correct’ the course of the well for many reasons. For example, it may be necessary in the event of the drillpipe becoming stuck in the hole to simply drill around the stuckpipe (or **fish**), or plug back the well to drill to an alternative target.

(e) Salt Dome Drilling

Salt domes (called **Diapirs**) often form hydrocarbon traps in what were overlying reservoir rocks. In this form of trap the reservoir is located directly beneath the flank of the salt dome. To avoid potential drilling problems in the salt (e.g. severe washouts, moving salt, high pressure blocks of dolomite) a directional well can be used to drill alongside the Diapir (not vertically down through it) and then at an angle below the salt to reach the reservoir.

(f) Relief Wells

If a blow-out occurs and the rig is damaged, or destroyed, it may be possible to kill the “wild” well by drilling another directionally drilled well (relief well) to intercept or pass to within a few feet of the bottom of the “wild” well. The “wild” well is killed by circulating high density fluid down the relief well, into and up the wild well.

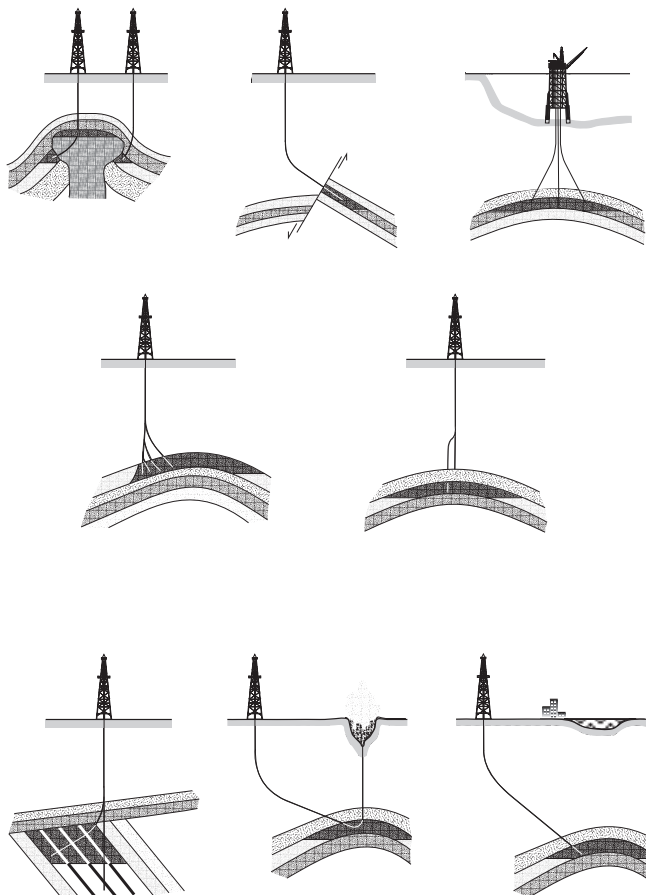

Figure 1 Applications of Directional Drilling

3. DEPTH REFERENCE AND GEOGRAPHICAL REFERENCE SYSTEMS

The trajectory of a deviated well must be carefully planned so that the most efficient trajectory is used to drill between the rig and the target location and ensure that the well is drilled for the least amount of money possible. When planning, and subsequently drilling the well, the position of all points along the wellpath and therefore the trajectory of the well must be considered in three dimensions (Figure 2). This means that the position of all points on the trajectory must be expressed with respect to a three dimensional reference system. The three dimensional system that is generally used to define the position of a particular point along the wellpath is:

- The vertical depth of the point below a particular reference point
- The horizontal distance traversed from the wellhead in a Northerly direction
- The distance traversed from the wellhead in an Easterly direction

The depth of a particular point in the wellpath is expressed in feet (or meters) vertically below a reference (**datum**) point and the Northerly and Easterly displacement of the point is expressed in feet (or meters) horizontally from the wellhead.

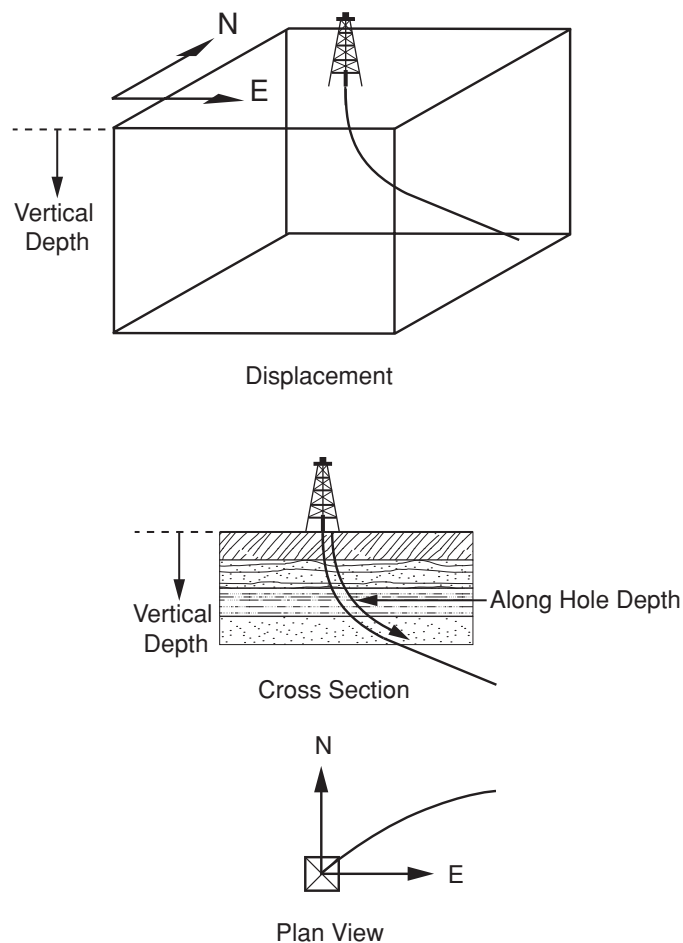

Figure 2 Well Planning Reference Systems



3.1 Depth Reference Systems

There are a number of datum systems used in the depth reference systems. The datum systems which are most widely used are :

- **Mean Sea Level, MSL**
- **Rotary Table Elevation, RTE**
- **20" Wellhead Housing**

The **Mean Sea Level, MSL** is a permanent, national and well documented datum whereas datum such as the **Rotary Table Elevation, RTE** only exists when the drilling rig is on site. The top of the **20" Wellhead Housing** is only available when the wellhead housing has been installed and will be removed when the well is abandoned. Hence, since the only permanent datum is the MSL (the rig will be removed and the wellhead may be removed on abandonment) the distance between the MSL and the rotary table on the drillfloor and the MSL and the wellhead housing must be measured and recorded carefully on the well survey documents. The elevation of the rotary table above the MSL will be measured when the drilling rig is placed over the drilling location.

The depths of the formations to be penetrated are generally referenced, by the geologists and reservoir engineers, to MSL since the Rotary Table Elevation will not be known until the drilling rig is in place. In most drilling operations the Rotary Table elevation (RTE) is used as the working depth reference since it is relatively simple, for the driller for instance, to measure depths relative to this point. The elevation of the RTE is also referred to as Derrick Floor Elevation (DFE). Depths measured from these references are often called depths below rotary table (BRT) or below derrick floor (BDF). The top of the kelly bushing is also used as a datum for depth measurement. In this case the depths are referred to as depths below rotary kelly bushing (RKB).

The depth of any point in the wellpath can be expressed in terms of the **Along Hole Depth (AHD)** and the **True Vertical Depth (TVD)** of the point below the reference datum. The AHD is the depth of a point from the surface reference point, measured along the trajectory of the borehole. Whereas the TVD is the vertical depth of the point below the reference point. The AHD will therefore always be greater than the TVD in a deviated well. Since there is no direct way of measuring the TVD, it must be calculated from the information gathered when surveying the well. The techniques used to survey the well will be discussed in the chapter on wellbore surveying.

3.2 Geographical Reference Systems

The position of a point in the well can only be defined in three dimensions when, in addition to the TVD of the point, its lateral displacement and the direction of that displacement is known. The lateral displacement is expressed in terms of feet (or meters) from the wellhead in a Northerly and Easterly direction or in degrees of **latitude and longitude**. All displacements are referenced to the wellhead position. The position of the wellhead is determined by land or satellite surveying techniques and quoted in latitude and longitude or an international grid co-ordinate system (e.g. **Universal Transverse Mercator UTM system**). Due to the large number

of digits in some grid co-ordinate systems, a local origin is generally chosen and given the co-ordinates zero, zero (0,0). This can be the location of the well being drilled, or the centre of an offshore platform. When comparing the position of points in a well, and in particular for anti-collision monitoring, it is important that all co-ordinate data are ultimately referenced to a single system.

4. PLANNING THE PROFILE OF THE WELL

There are basically three types of deviated well profile (Figure 3):

- Build and Hold
- S-shaped
- Deep kick-off

The build and hold profile is the most common deviated well trajectory and is the most simple trajectory to achieve when drilling. The S-shaped well is more complex but is often required to ensure that the well penetrates the target formation vertically. This type of trajectory is often required by reservoir engineers and production technologists in exploration and appraisal wells since it is easier to assess the potential productivity of exploration wells, or the efficiency of stimulation treatments when the productive interval is entered vertically, at right angles to the bedding planes of the formation. The deep kick-off profile may be required when drilling horizontal wells or if it is necessary to drill beneath an obstacle such as the flank of a Salt Diapir. This well profile is the most difficult trajectory to drill since it is necessary to initiate the deviated trajectory in deeper, well compacted formations.

4.1 Parameters Defining the Wellpath

There are three specific parameters which must be considered when planning one of the trajectories shown in Figure 3. These parameters combine to define the trajectory of the well and are the:

- **Kick-off Point**
- **Buildup and Drop off Rate** and
- **Tangent Angle** of the well

(a) The Kickoff Point (KOP)

The **kick off point** is the **along hole measured depth** at which a change in inclination of the well is initiated and the well is orientation in a particular direction (in terms of North, South, East and West). In general the most distant targets have the shallowest KOPs in order to reduce the inclination of the **tangent section** of the well (see below). It is generally easier to kick off a well the shallow formations than in deep formations. The kick-off should also be initiated in formations which are stable and not likely to cause drilling problems, such as unconsolidated clays.

(b) Buildup Rate (BUR) and Drop Off Rate (DOR)

The **build up rate and drop off rate** (in degrees of inclination) are the rates at which the well deviates from the vertical (usually measured in degrees per 100 ft drilled). The build-up rate is chosen on the basis of drilling experience in the location and the tools available, but rates between 1 degree and 3 degree per 100ft

of hole drilled are most common in conventional wells. Since the build up and drop off rates are constant, these sections of the well, by definition, form the arc of a circle. Build up rates in excess of 3 degrees per 100 ft are termed **doglegs** when drilling conventional deviated wells with conventional drilling equipment. The build up rate is often termed the **dogleg severity**.

(c) Tangent (or Drift) Angle

The **tangent angle (or drift angle)** is the inclination (in degrees from the vertical) of the long straight section of the well after the build up section of the well. This section of the well is termed the tangent section because it forms a tangent to the arc formed by the build up section of the well. The tangent angle will generally be between 10 and 60 degrees since it is difficult to control the trajectory of the well at angles below 10 degrees and it is difficult to run wireline tools into wells at angles of greater than 60 degrees.

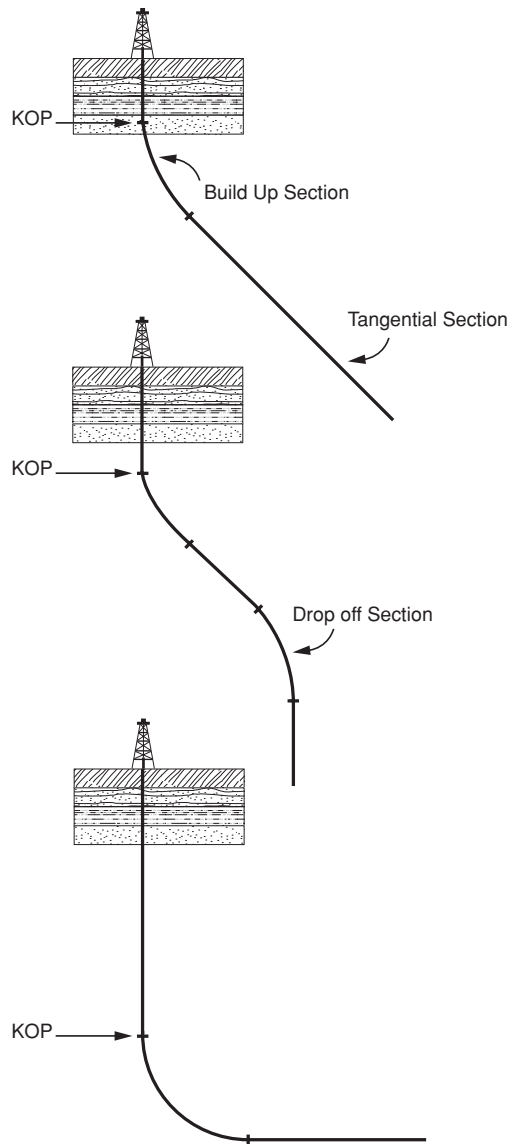

Figure 3 Standard Well Trajectories

4.2 Defining the Points on the Wellpath

Having fixed the target and the rig position, the next stage is to plan the geometrical profile of the well to reach the target. The most common well trajectory is the build and hold profile, which consists of 3 sections - vertical, build-up and tangent.

The trajectory of the wellbore can be plotted when the following points have been defined :

- KOP (selected by designer)
- TVD and horizontal displacement of the end of the build up section.
- TVD and horizontal displacement of the target (defined by position of rig and target)

Since the driller will only be able to determine the along hole depth of the well the following information will also be required:

- AHD of the KOP (same as TVD of KOP)
- Build up rate for the build up section (selected by designer)
- Direction in which the well is to be drilled after the KOP in degrees from North (defined by position of rig and target)
- AHD at which the build up stops and the tangent section commences and
- AHD of the target

These depths and distances can be defined by a simple geometrical analysis of the well trajectory (Figure 4).

Radius of the Build Up Section:

The radius R of the build up section of the well can be calculated from the build-up rate ($\gamma^\circ/100\text{ft}$) :

$$\frac{\gamma^\circ}{360} = \frac{100\text{ft}}{2\pi(R)} \quad R = \frac{36000}{2\pi(\gamma)}$$

Tangent Angle:

The tangent angle, α of the well (Figure 4) can be calculated as follows:

$$\tan x = \frac{d - R}{D}$$

$$\sin y = \frac{R \cos x}{D}$$

$$\alpha = x + y$$

Note : It is possible for angle x to be negative if $d < R$, but these equations are still valid.

Once the tangent angle is known the other points on the wellpath can be calculated as follows:



AHD at the end of build section:

The measured depth at end of build section, AE:

$$AE = AB + BE \text{ (curved length)}$$

$$BE \text{ can be calculated from } \frac{BE}{2\pi R} = \frac{\alpha}{360}$$

TVD at the end of the build Section:

The TVD at end of build section, AX is

$$AX = AB + PE$$

$$\text{where } PE = R \sin \alpha$$

$$AX = AB + R \sin \alpha$$

Displacement at the end of build Section:

The horizontal deviation at end of build, XE is

$$XE = OB - OP$$

$$\text{where } OB = R$$

$$OP = R \cos \alpha$$

$$XE = R - R \cos \alpha$$

AHD of the target:

The total measured depth, AT is

$$AT = AE + ET$$

Example:

The planning procedure for the build and hold trajectory is best illustrated by considering the following example:

Basic Data:

KOP (BRT)	-	2000 ft
TVD of target (BRT)	-	10000 ft
horizontal Displacement of Target	-	3000 ft
build-up rate	-	2 degrees/100 ft

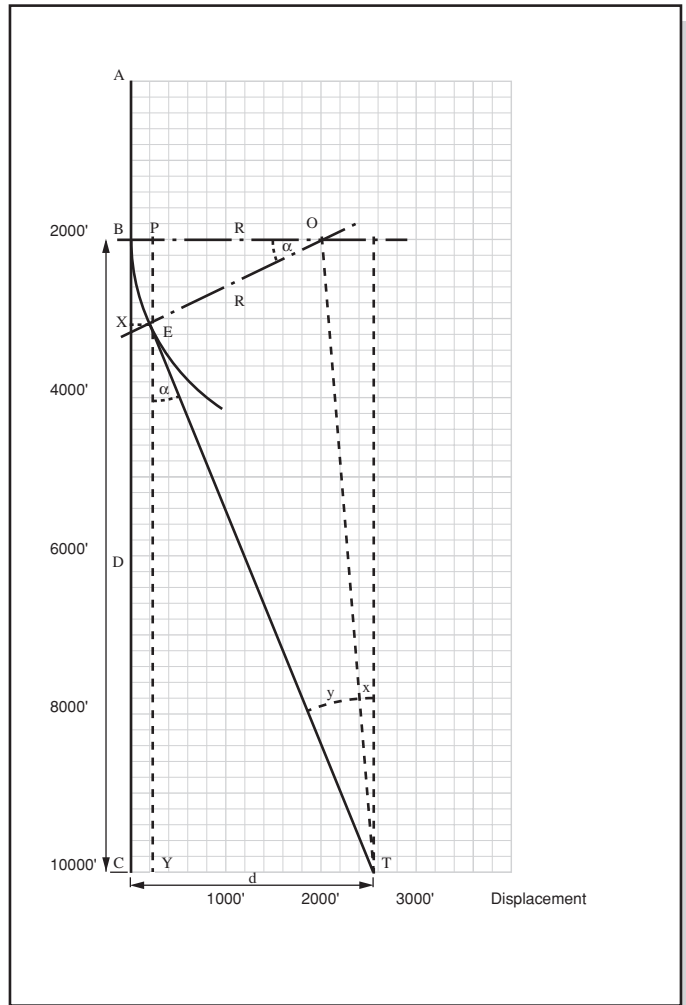

Figure 4 Design of the Well Trajectory

4.2.1 Scaled Diagrams

Using a scaled diagram, this information can simply be plotted on a piece of graph paper using a compass and a ruler (Figure 4). Point A represents the rig location on surface. Point B is the KOP at 2000'. Point T is the target. Point O defines the centre of the arc which forms the Buildup section.

The radius OB can be calculated from build-up rate:

$$\text{i.e. } \frac{2^\circ}{360} = \frac{100'}{2\pi(\text{OB})} \quad \text{OB} = \frac{9000}{\pi} = 2866.24'$$

An arc of this radius can be drawn to define the build-up profile. A tangent from T can then be drawn to meet this arc at point E. The drift angle TEY can then be measured with a protractor. Note that TEY = BOE. From this information the distances BX, XE, BE, EY can be calculated.



This method of defining the well trajectory is not however very accurate, since an error of 1 degree or 2 degrees in measuring TEY with a protractor may mean that the tangent trajectory is imprecise and that the target may be missed by the driller.

4.2.2 Geometrical Calculation Technique

The drift angle TEY can alternatively be calculated as follows (Figure 4).

In the example:

$$\tan x = \frac{3000 - 2866.24}{8000} \Leftrightarrow x = 0.96^\circ$$

$$\sin y = \frac{2866.24 \cos 0.96}{8000} \Leftrightarrow y = 20.99^\circ$$

$$\alpha = 21.95^\circ$$

Note : It is possible for angle x to be negative if $d < R$, but these equations are still valid.

Once the drift angle is known the other points on the wellpath can be calculated as follows:

AE (measured depth at end of build section)

$$AE = AB + BE \text{ (curved length)}$$

$$BE \text{ can be calculated from } \frac{BE}{2\pi R} = \frac{\alpha}{360} \Leftrightarrow BE = 1097.50'$$

$$AE = 2000 + 1097.50 = \underline{\underline{3097.50'}}$$

AX (TVD at end of build)

$$AX = AB + PE$$

$$\text{where } PE = R \sin \alpha = 1071.39'$$

$$AX = 2000 + 1071.39 = \underline{\underline{3071.39'}}$$

XE (horizontal deviation at end of build)

$$XE = OB - OP$$

where $OB = R$

$$OP = R \cos \alpha = 2658.47'$$

$$XE = 2866.24 - 2658.47 = \underline{207.77'}$$

AT (total measured depth)

$$AT = AE + ET$$

ET can be calculated from;

$$ET = \frac{8000 - 1071.39}{\cos 21.95^\circ} = 7470.12'$$

$$AT = 3097.50 + 7470.12 = \underline{10567.62'}$$

Exercise 1 Designing a Deviated Well

It has been decided to sidetrack a well from 1500 ft. The sidetrack will be a build and hold profile with the following specifications:

Target Depth	: 10000 ft.
Horizontal departure	: 3500 ft.
Build up Rate	: 1.5° per 100 ft.

Calculate the following :

- the drift angle of the well.
- the TVD and horizontal deviation at the end of the build up section.
- the total measured depth to the target.

5. CONSIDERATIONS WHEN PLANNING THE DIRECTIONAL WELL PATH

When planning a directional well a number of technical constraints and issues will have to be considered. These will include the:

- Target location
- Target size and shape
- Surface location (rig location)
- Subsurface obstacles (adjacent wells, faults etc.)



In conjunction with the above constraints the following factors must be considered in the geometrical design of the well:

- Casing and mud programmes
- Geological section

(a) Target Location

The location of the target is chosen by the geologists and/or the reservoir engineers. The target location will be specified in terms of a geographical co-ordinate system such as longitude and latitude or a grid co-ordinate system such as the UTM system. The grid reference system, in which the co-ordinates are expressed in terms of feet (or meters) north and east of a local or national reference point, is particularly useful when planning the directional well path, since the displacement of all points on the wellpath can be easily calculated.

The depth of the target is generally expressed by the geologist in terms of true vertical depth, TVD below a national reference datum such as Mean Sea Level. The difference between this national reference point and the drilling reference datum (such as the Rotary table) must be computed so that the driller can translate the computed TVD of the borehole below the rotary table elevation, into depth below mean sea level, and therefore proximity to the target.

(b) Specification of Target, Size and Shape

The size and shape of the target is also chosen by geologists and/or reservoir engineers. The target area will be dictated by the shape of the geological structure and the presence of geological features, such as faults. In general the smaller the target area, the more directional control that is required, and so the more expensive the well will be.

(c) Rig Location

The position of the rig must be considered in relation to the target and the geological formations to be drilled (e.g. salt domes, faults etc.). If possible the rig will be placed directly above the target location. When developing a field from a fixed platform the location of the platform will be optimised so that the directionally drilled wells can reach the full extent of the reservoir.

(d) Location of Adjacent Wells

Drilling close to an existing well can be very dangerous, particularly if the existing well is on production. This is especially true just below the seabed on offshore platforms, where the wells are very closely spaced. The proposed wellpath must be designed so that it avoids all other wells in the vicinity. It is essential that the possible errors in determination of the existing and proposed wells are considered when the trajectory of the new well is designed.

(e) Geological Section

The equipment and techniques involved in controlling the deviated wellpath are not suited to certain types of formation. It is for example difficult to initiate the deviated portion of the well (kickoff the well) in unconsolidated mudstone. The engineer may therefore decide to drill vertically through the problematic formation and commence the deviated part of the well once the well has entered the next

most suitable formation type. The vertical depth of the formation tops will be provided by the geologists.

(f) Casing and Mud Programmes

The trajectory of the well will be designed so that the most difficult parts of the well are drilled through competent formations, minimising problems whilst drilling the well. It is very common to initiate the kick-off just below the surface casing and possibly to change out to oil-based mud when drilling the build-up section. In highly deviated wells the build-up section of the well may also be cased off before drilling the long, tangent section of the well. Oil-based mud may also be used in the long tangent sections of the well. The trajectory of the well will therefore be designed so that these operations correspond to the casing setting depths which have been selected for many other reasons. This is an iterative process taking into account all of the considerations when designing the well.

6. DEFLECTION TOOLS

There are a number of tools and techniques which can be used to change the direction in which a bit will drill. These tools and techniques can be used to change the inclination or the azimuthal direction of the wellbore or both. All of these tools and techniques work on one of two basic principles. The first principle is to introduce a **bit tilt angle** into the axis of the BHA just above the bit and the second is to introduce a **sideforce** to the bit (See Figure 5). The introduction of a tilt angle or sideforce to the bit will result in the bit drilling off at an angle to the current trajectory.

The major tools currently used for this purpose are:

- Bent Sub and Positive Displacement Motor
- Non-Rotating Steerable Drilling Systems
- Rotary Steering System
- Directional Bottom Hole Assemblies (BHA)
- Whipstocks

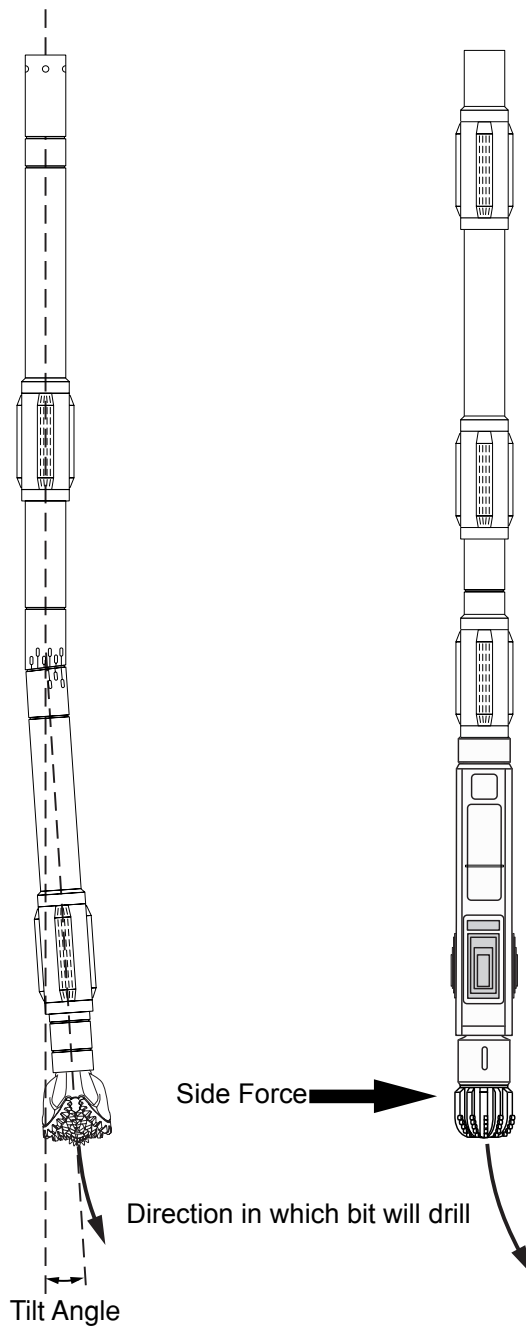

Figure 5 Bit tilt angle and Sideforce

6.1 Bent Sub and Mud Motor

The most commonly used technique for changing the trajectory of the wellbore uses a piece of equipment known as a “bent sub” (Figure 6) and a **Positive Displacement** (mud) motor. A **bent sub** is a short length of pipe with a diameter which is approximately the same as the drillcollars and with threaded connections on either end. It is manufactured in such a way that the axis of the lower connection is slightly offset (less than 3 degrees) from the axis of the upper connection. When made up into the BHA it introduces a “**tilt angle**” to the elements of the BHA below it and therefore to the axis of the drillbit. However, the introduction of a bent sub

into the BHA means that the centre of the bit is also offset from the centre line of the drillstring above the bent sub and it is not possible therefore to rotate the drillbit by rotating the drillstring from surface. Even if this were possible, the effect of the tilt angle would of course be eliminated since there would be no preferential direction for the bit to drill in.

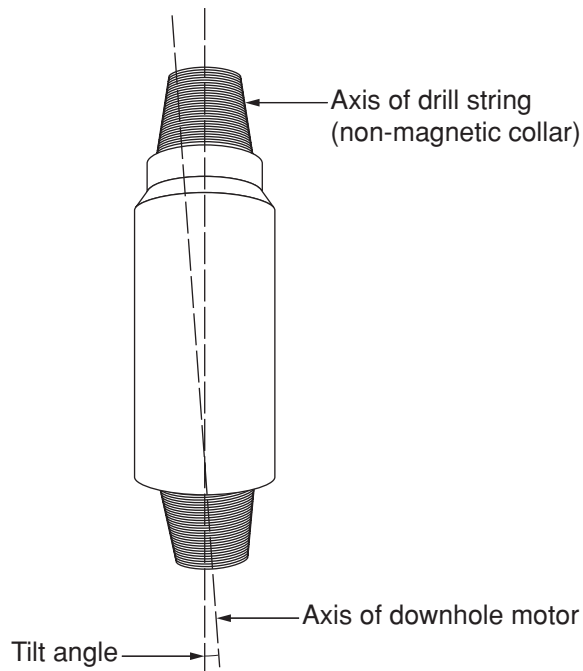

Figure 6 Bent Sub

The bent sub must therefore be used in conjunction with a **Positive Displacement Motor, PDM** or a **Drilling Turbine**. The PDM is often called a **mud motor** and is used in far more wells than the turbine. A detailed description, and some technical specifications, of mud motors and turbines is provided in the Appendix at the end of this chapter.

The mud motor is made up into the BHA of the drillstring below the bent sub, between the bent sub and drillbit (See Figure 7). When drilling fluid is circulated through the drillstring the inner shaft of the mudmotor, which is connected to the bit, rotates and therefore the bit rotates. It is therefore not necessary to rotate the entire drillstring from surface if a mud motor is included in the BHA. Mud motors and turbines are rarely used when not drilling directionally because they are expensive pieces of equipment and do wear out.

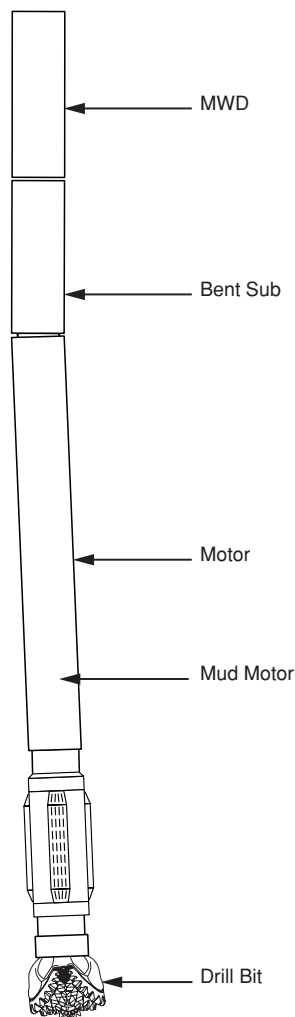

Figure 7 BHA with bent sub and mudmotor

A scribe line is marked on the inside of the bend of the bent sub, and this indicates the direction in which the bit will drill (this direction is known as the “**tool face**”). A directional surveying tool (quite often an MWD tool) is generally run as part of the BHA, just above the bent sub so that the trajectory of the well can be checked periodically as the well is deviating.

The bent sub and PDM can of course only be used in the build up or drop off portion of the well since the bit will continue to drill in the direction of the tilt angle as long as the bent sub is in the assembly and the mud motor is being used to rotate the bit. This leads to the major disadvantage of using a bent sub and PDM to change the trajectory of the well.

When drilling a well, the “conventional” assembly (without bent sub and mud motor) used to drill the straight portion of the well must be pulled from the hole and the bent sub and PDM assembly run in hole before the well trajectory can be changed. The bent sub and motor will then be used to drill off in a particular direction. When the well is drilling in the required direction (inclination and azimuth), the bent sub and PDM must then be pulled and the conventional assembly re-run. Otherwise the

drillbit would continue to change direction. This is a very time consuming operation (taking approximately 8 hrs at 10,00 ft depth for each trip out of, and into, the hole). Remember however that the build up section of a well can be 1-2000 ft long depending on the build up rate (typically 1-3 degrees/100ft) and the required inclination and therefore the bent sub and mud motor will be, depending on the rate of penetration, in the well for quite a long time time.

6.2 Steerable Drilling Systems

A **steerable drilling system** allows directional changes (azimuth and/or inclination) of the well to be performed without tripping to change the BHA, hence its name. It consists of: a drill bit; a stabilized positive displacement steerable mud motor; a stabilizer; and a directional surveying system which monitors and transmits to surface the hole azimuth, inclination and toolface on a real time basis (See Figure 8).

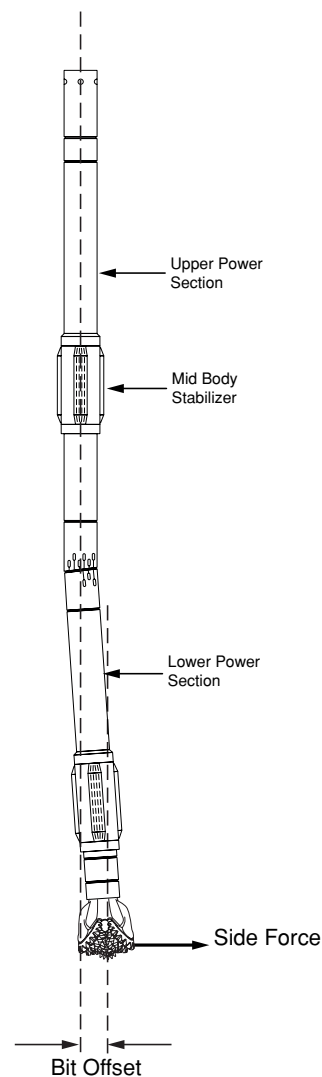

Figure 8 Steerable drilling system

The capability to change direction at will is made possible by placing the tilt angle very close to the bit, using a navigation sub on a standard PDM. This tilt angle can be used to drill in a specific direction, in the same way as the tilt angle generated



by a bent sub with the the drillbit being rotated by the mud motor when circulating. However, since the tilt angle is much closer to the bit than a conventional bent sub assembly, it produces a much lower bit offset and this means that the drill bit can also be rotated by rotating the entire string at surface (in the same way as when using a conventional assembly). Hence the steerable assembly can be used to drill in a specific direction by orienting the bent sub in the required direction and simply circulating the fluid to rotate the bit (as in the bent sub assembly) or to drill in a straight line by both rotating and circulating fluid through the drillstring. When rotating from surface we will of course be circulating fluid also and therefore the rotation of the bit generated by the mud motor will be super-imposed on the rotation from surface. This does not alter the fact that the effect of the bit tilt angle will be eliminated by the rotation of the entire assembly.

When using the navigation sub and mud motor to drill a deviated section of hole (such as build up or drop off section of hole) the term “**oriented or sliding**” drilling is used to describe the drilling operation. When drilling in a straight line, by rotation of the assembly, the term “**rotary**” drilling is used to describe the drilling operation. The directional tendencies of the system are principally affected by the navigation sub tilt angle and the size and distance between the PDM stabilizer and the first stabilizer above the motor.

The steerable drilling systems are particularly valuable where: changes in the direction of the borehole are difficult to achieve; where directional control is difficult to maintain in the tangent sections of the well (such as in formations with dipping beds) or where frequent changes may be required.

The steerable systems are used in conjunction with MWD tools which contain petrophysical and directional sensors. These types of MWD tools are often called Logging Whilst Drilling, LWD tools. The petrophysical sensors are used to detect changes in the properties of the formations (lithology, resistivity or porosity) whilst drilling and therefore determine if a change in direction is required. Effectively the assembly is being used to track desirable formation properties and place the wellbore in the most desirable location from a reservoir engineering perspective. The term “**Geosteering**” is often used when the steerable system is used to drill a directional well in this way.

6.2.1 Components

There are five major components in a Steerable Drilling System (Figure 11). These components are:

- (a) Drill Bit
- (b) Mud Motor
- (c) Navigation Sub
- (d) Navigation Stabilizers
- (e) Survey System

- (a) Drill Bit

Steerable systems are compatible with either tricone or PDC type bits. In most cases, a PDC bit will be used since this eliminates frequent trips to change the bit.

(b) PDM

The motor section of the system causes the bit to rotate when mud is circulated through the string. This makes oriented drilling possible. The motors may also have the navigation sub and a bearing housing stabilizer attached to complete the navigation motor configuration.

(c) Navigation Sub

The navigation sub converts a standard Mud motor into a steerable motor by tilting the bit at a predetermined angle. The bit tilt angle and the location of the sub at a minimal distance from the bit allows both oriented and rotary drilling without excessive loads and wear on the bit and motor. The design of the navigation sub ensures that the deflecting forces are primarily applied to the bit face (rather than the gauge) thereby maximizing cutting efficiency.

Two types of subs are presently available for steerable Systems:

- The double tilted universal joint housing or DTU and
- The tilted kick-off sub or TKO.

The DTU and TKO both utilize double tilts to produce the bit tilt required for hole deflection. The DTU's two opposing tilts reduce bit offset and sideload forces, and thereby maintaining an efficient cutting action. The TKO has two tilts in the same direction that are close to the bit.

(d) Navigation Stabilisers

Two specially designed stabilizers are required for the operation of the system and influence the directional performance of a steerable assembly. The motor stabilizer or **Upper Bearing Housing Stabiliser, UBHS** is an integral part of the navigation motor, and is slightly undergauge. The upper stabilizer, which defines the third tangency point, is also undergauge and is similar to a string stabilizer. The size and spacing of the stabilizers also can be varied to fine-tune assembly reactions in both the oriented and rotary modes.

(e) Survey System

A real time downhole survey system is required to provide continuous directional information. A **measurement while drilling, MWD** system is typically used for this purpose. An MWD tool will produce fast, accurate data of the hole inclination, azimuth, and the navigation sub toolface orientation. In some cases, a wireline steering tool may be used for this purpose.

6.2.2 Dogleg Produced by a Steerable System

When oriented drilling, the **theoretical geometric dogleg severity or TGDS** produced by the system is defined by three points on a drilled arc (Figure 12). The three points required to establish the arc are:

- The Bit
- The PDM stabilizer or Upper Bearing Housing Stabilizer.
- The first stabilizer above the mud motor (upper stabiliser).

The radius of the arc is further determined by the tilt of the navigation sub, as seen in the Figure 12. The following basic relationship is produced by mathematical derivation.

$$\frac{\text{TGDS(Degrees / 100ft)} = 200 \times \text{TiltAngle}}{L_1 + L_2}$$

where:

- Tilt angle = Bit tilt in degrees
- L = length between bit and upper stabilizer (L1 + L2)
- L1 = length between UBHS and the upper Stabilizer
- L2 = length between UBHS and the bit

This dogleg rate or TGDS is that created when the steerable system drills in the oriented mode. Furthermore, the theory considers that the system has full gauge stabilizers.

6.2.3 Operation of a Steerable System

As described above, the steerable system can drill directionally or straight ahead, as required. This enables the driller to control the well's trajectory without making time-consuming trips to change bottomhole assemblies. To steer the hole during kickoffs or course corrections the system is **oriented** using MWD readings so the bit will drill in the direction of the navigation sub's offset angle. When drilling in this way the system is said to be drilling in the **oriented or sliding** (since the drillstring is not rotating) **mode**. The bit is driven by the downhole motor, and the rotary table is locked in place, as it is when conventional motor drilling. As mentioned previously, the system's two stabilizers and bit serve as the tangency points that define the curve to be drilled by the oriented assembly. The dogleg rate produced can be controlled by varying the placement and size of the stabilizers, by using a DTU with a different offset angle, or by alternating drilling with oriented and rotary intervals.

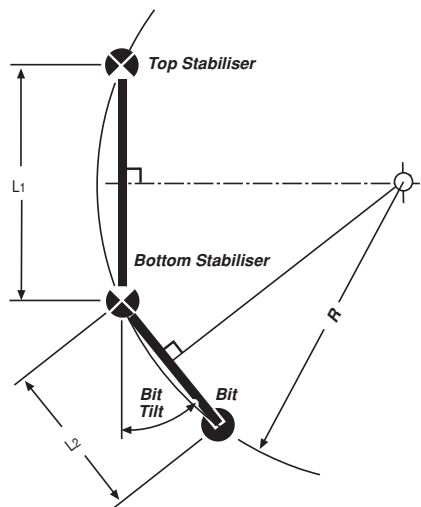

Figure 9 Dogleg severity

The system can also be used to drill straight ahead by simple string rotation. The rotary table is typically turned at 50-80 RPM while the motor continues to run. When drilling in this way the system is said to be drilling in the **rotating mode**. Through careful well planning and bottomhole assembly design, oriented sections are minimized and the assembly is rotated as much as possible. This maximizes penetration rates while keeping the well on course. Survey readings from an MWD tool enable efficient monitoring of directional data so the driller can maintain the wellpath close to the desired path. Slight deviations can be detected and corrected with minor **oriented drilling** intervals before they become major problems.

6.3 Rotary Steering System

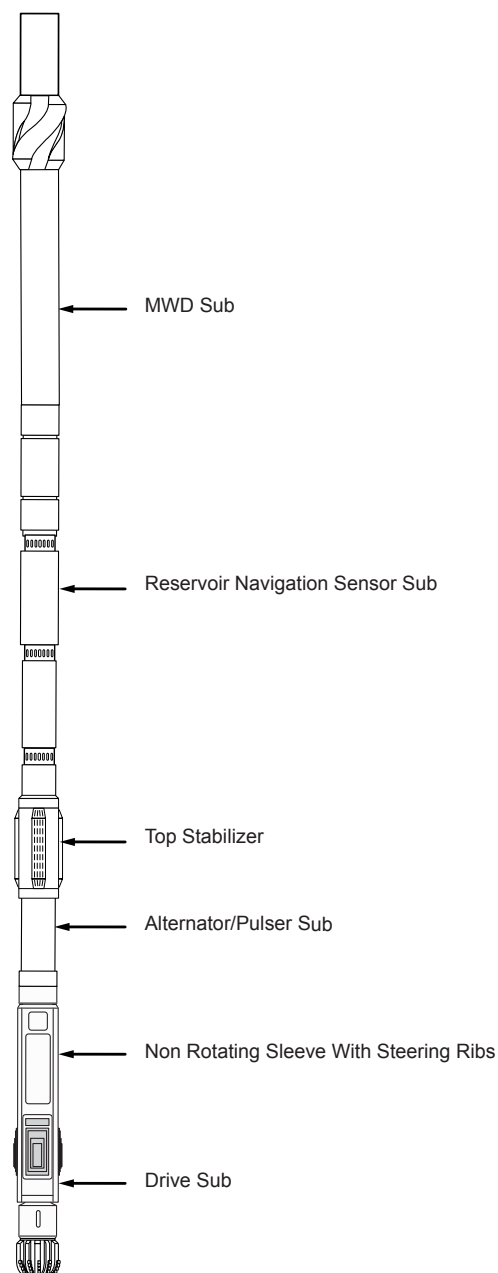

Figure 10 Rotary steering system (Courtesy of Baker Hughes Inteq.)



The rotary steering system described here operates on the principle of the application of a sideforce in a similar way to the non-rotating systems described above. However, in these systems it is also possible to rotate the drillstring even when drilling directionally or as described above when in the "**oriented mode**" of drilling. It is therefore possible to rotate the string at all times during the drilling operation. This is desirable for many reasons but mostly because it has been found that it is much easier to transport drilled cuttings from the wellbore when the drillstring is rotating. When the drillstring is not rotating there is a tendency for the cuttings to settle around the drillstring and it may become stuck.

There are a number of tools which have been developed in order to allow the string to be rotated whilst drilling in the oriented mode but only one of these devices will be described below. Other systems (developed and offered by other service companies) can be found on the internet.

The main elements of the rotary steerable steering system that is described here (the AutoTrak™ RCLS system) are the: Downhole System and the Surface System

6.3.1 Downhole System

The downhole system consists of:

- The Non-Rotating Steerable Stabiliser;
- The electronics probe and
- The Reservoir navigation or MWD Tool.

Non-Rotating Steerable Stabilizer

The Steering Unit contained within a non-rotating sleeve controls the direction of the bit. A drive shaft rotates the bit through the non-rotating sleeve. The sleeve is decoupled from the drive shaft and is therefore not affected by drillstring rotation. This sleeve contains three hydraulically operated ribs, the near bit inclinometer and control electronics. Pistons – operated by high pressure hydraulic fluid – exert controlled forces separately to each of the three steering ribs. The system applies a different, controlled hydraulic force to each steering rib and the resulting force vector directs the tool along the desired trajectory at a programmed dogleg severity. This force vector is adjusted by a combination of downhole electronic control and commands pulsed hydraulically from the surface.

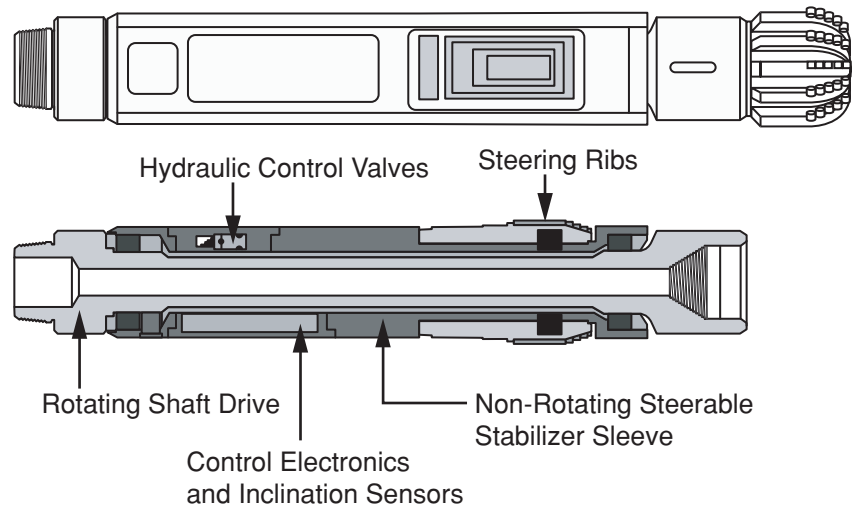

Figure 11 Non-Rotating Steerable Stabilizer (Courtesy of Baker Hughes Inteq.)

The micro-processing system inside the AutoTrak RCLS calculates how much pressure has to be applied to each piston to obtain the desired toolface orientation. In determining the magnitude of the force applied to the steering ribs, the system also takes into account the dogleg limits for the current hole selection.

In field tests, the sleeve has been seen to rotate at approximately one revolution every Ω hour, depending on both the formation type and ROP. To compensate, the system continuously monitors the relative position of the sleeve. Using these data, AutoTrak RCLS automatically adjusts the force on each steering rib to provide a steady side force at the bit in the desired direction.

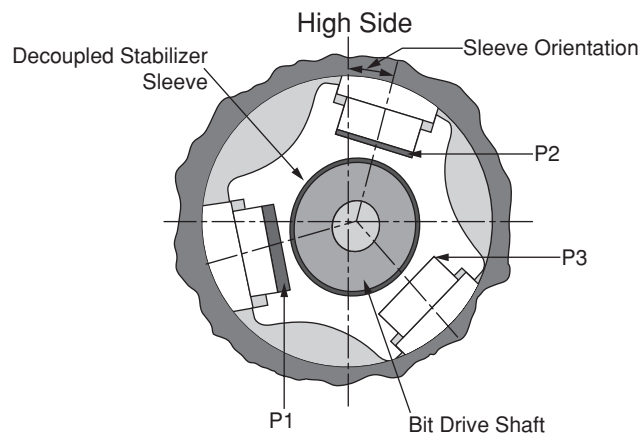

Figure 12 End section of Non-Rotating Steerable Stabilizer (Courtesy of Baker Hughes Inteq.)

Electronics Probe

The Electronics Probe controls the interface between all tool components and manages the exchange of data to and from the surface. This section also contains directional and tool vibration sensors. Azimuth measurements from the tri-axial



magnetometer monitor and control the steering unit in conjunction with the near bit inclinometer, providing early readings of tool inclination changes. The vibration sensor helps ensure that AutoTrak RCLS is operated within specifications and at maximum efficiency.

Reservoir Navigation Tool

The Reservoir Navigation Tool (RNT) sub – with Multiple Propagation Resistivity (MPR) and Dual Azimuthal Gamma Ray (GR) sensors – enables real-time geosteering within the reservoir. Using two frequencies and dual transmitters, the RNT provides four (4) compensated resistivity measurements for accurate determination of R_t under a variety of conditions. The system provides deep-reading 400 kHz measurements and high vertical resolution 2 MHz readings. While drilling horizontally, the 400 kHz readings can detect contrasting bed boundaries and fluid contacts up to 18 feet (5.5 m) from the tool. In a horizontal application, this enables drillers to anticipate boundaries more than 250 ft (75 m) ahead of the bit. These two frequency readings and Dual Azimuthal Gamma Ray measurement enable AutoTrak operators to downlink course corrections to keep the well in the zone of interest.

6.3.2 Surface System

AutoTrak's Surface System has two main elements: **Surface Computer System and the By-Pass Actuator**

Surface Computer System

The **Surface Computer System** encodes the downlink signals for transmission to the tool and decodes the MWD signals received from downhole. It also provides standard directional and LWD outputs. This system includes the central processor and an MWD decoding unit. Downlink communication with the AutoTrak RCLS tool is controlled either by the computer or manually from the keypad. The downhole system is programmed by using the negative pulse telemetry created in the surface By-Pass Actuator.

By-Pass Actuator

The **By-Pass Actuator (BPA)** valve unit transmits commands to the downhole tool through negative mud pulse telemetry. Each valve unit is fully certified by Det Norske Veritas. The by-pass actuator is connected to the standpipe and can divert some of the mud flow to create a series of negative pulses in the drill pipe. The tool senses and decodes these as downlink instructions. A complete downlink command can take between 2 and 8.5 minutes depending upon the complexity of the downlink. After the AutoTrak RCLS downhole tool receives the downlink information, it sends a confirmation message back to the surface, then reconfigures itself for the task required.

Automated operation of downlink can be performed as drilling proceeds, allowing control of AutoTrak RCLS without interrupting the progress of the well.

6.4 Directional Bottom Hole Assemblies (BHA)

A conventional rotary drilling assembly is normally used when drilling a vertical well, or the vertical or tangent sections of a deviated well. When using a steerable assembly in a deviated well it is of course possible to drill the tangent sections of the well with the steerable assembly.

The BHA of the conventional assembly can also be designed in such a way as to result in an increase or decrease in the inclination of the wellbore but it is very difficult to predict the rate at which the angle will increase or decrease with a conventional BHA and therefore this technique is not widely used today.

The tendency of a conventional BHA to result in an increase or decrease in hole angle is a function of the flexibility of the BHA. Since all parts of the drillstring are flexible to some degree (even large, heavy drill collars) the BHA will bend when weight is applied to the bit. This will introduce a tilt angle at the bit. The magnitude and orientation of the tilt angle will depend on the stiffness of the drill collars, the WOB and the number and position of the stabilizers in the BHA. A great deal of research was conducted in the 1960s and 70s, in an attempt to predict the directional tendencies of BHAs with but it is very difficult to predict the impact of the above variables on the rate at which the angle will increase or decrease and therefore this technique is not widely used today.

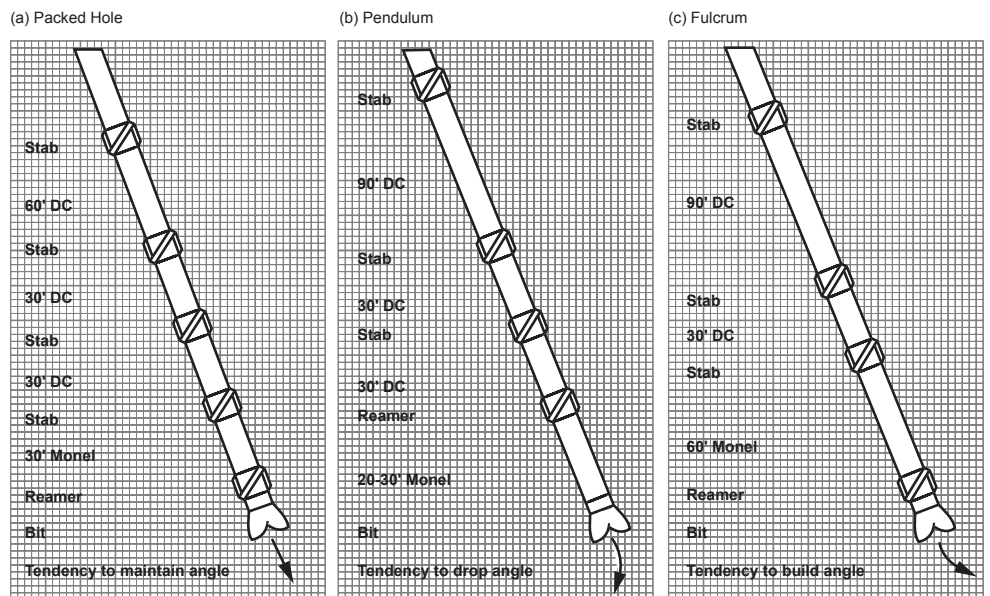

Figure 13 Directional BHA's

Three types of drilling assemblies have been used in the past to control the hole deviation:

6.4.1 Packed Hole Assembly

This type of configuration is a very stiff assembly, consisting of drill collars and stabilizers positioned to reduce bending and keep the bit on course. This type of assembly is often used in the tangential section of a directional hole. In practice it is very difficult to find a tangent assembly which will maintain tangent angle and direction. Short drill collars are sometimes used, and also reamers or stabilizers run in tandem. A typical packed hole assembly is given in Figure 13a.



6.4.2 Pendulum Assembly

The principles behind a Pendulum Assembly is that the unsupported weight of drill collars will force the bit against the low side of the hole. The resulting decrease or drop off in angle depends on WOB, RPM, stabilization and the distance between the bit and the first reamer (Figure 13b). The basic drop off assembly is: Bit - Monel DC - reamer - DC - stab - DC - stab - 90' DC - stab

To increase the tendency to drop angle :

- Apply less WOB (lower penetration rate)
- Apply more RPM and pump pressure in soft formations where jetting and
- Reaming down is possible
- Use bigger size Monel DC below the reamer, small DCs above.

6.4.3 Fulcrum Assembly

The principles behind a Fulcrum Assembly is to place a reamer near the bit (Figure 13c) and apply a high WOB. When WOB is applied, the DCs above the reamer will tend to bend against the low side of hole, making the reamer act as a fulcrum forcing the bit upwards. The rate of build up depends on WOB, size of collars, position of reamer and stabilization above the reamer. The basic build-up assembly is: Bit - sub - reamer - Monel DC - DC - stab - DC - stab - 90'DC - stab

To increase the build:

- Add more WOB
- Use smaller size monel (increase buckling effect)
- Reduce RPM and pump rates in soft formations

6.5 Whipstocks

The whipstock is a steel wedge, which is run in the hole and set at the KOP. This equipment is generally used in cased hole when performing a sidetracking operation for recompletion of an existing well. The purpose of the wedge is to apply a sideforce and deflect the bit in the required direction. The whipstock is run in hole to the point at which the sidetrack is to be initiated and then a series of mills (used to cut through the casing) are used to make a hole in the casing and initiate the sidetrack. When the hole in the casing has been created a drilling string is run in hole and the deviated portion of the well is commenced.

APPENDIX - I : Positive Displacement Motors (PDM's) and Turbodrills

A. POSITIVE DISPLACEMENT MOTORS (PDM)

A PDM is a downhole mud motor that uses the reverse Moineau pump principle to drive the bit without rotating the entire drillstring. It can be powered using drilling fluid, air or gas. The tool consists of 4 main sections (Figure 14).

- (a) dump valve - a by-pass valve which allows the drillstring to fill up or drain when tripping in or out of the hole
- (b) motor assembly - consists of a rubber lined stator which contains a spirally shaped cavity of elliptical cross-section. Running through the length of this cavity is a solid steel shaft which is also spiral in shape. The top end of the shaft or rotor is free, and the lower end fixed to a connecting rod
- (c) connecting rod - equipped with a universal joint at each end to accommodate the eccentric rotation of the rotor and transfer this rotation to the drive shaft
- (d) bearing and drive shaft assembly - consists of thrust bearings and a radial bearing to allow smooth rotation of the drive shaft. The bearings are lubricated by the mud. The drive shaft is then connected to a bit sub, which is the only external rotating part of the mud motor.

In some PDMs multi-stage (usually 3 stage) motors are now used. When drilling fluid is pumped through the motor it is forced under pressure into cavities between rotor and stator. The design of the motor is such that the rotor is forced to turn clockwise. This rotation is transferred via the drive shaft to the bit.

In a PDM drilling torque is proportional to the pressure differential across the motor. When WOB is applied the circulating pressure must increase. As the bit drills off the pressure decreases. It is therefore possible to use the mud pressure gauge as a weight and torque indicator. Experience has shown that the proper weight on bit is achieved when the pump pressure is 100 - 150 psi above free circulating pressure (i.e. when bit hanging free off bottom). Typical specifications and performance curves for a PDM are given in Figure 15.

To deviate a well a bent PDM housing is used or a bent sub is run above the PDM . A bent housing requires the connecting rod assembly to be modified so that the tool has a slight bend. A bent sub can be used to create the same effect.

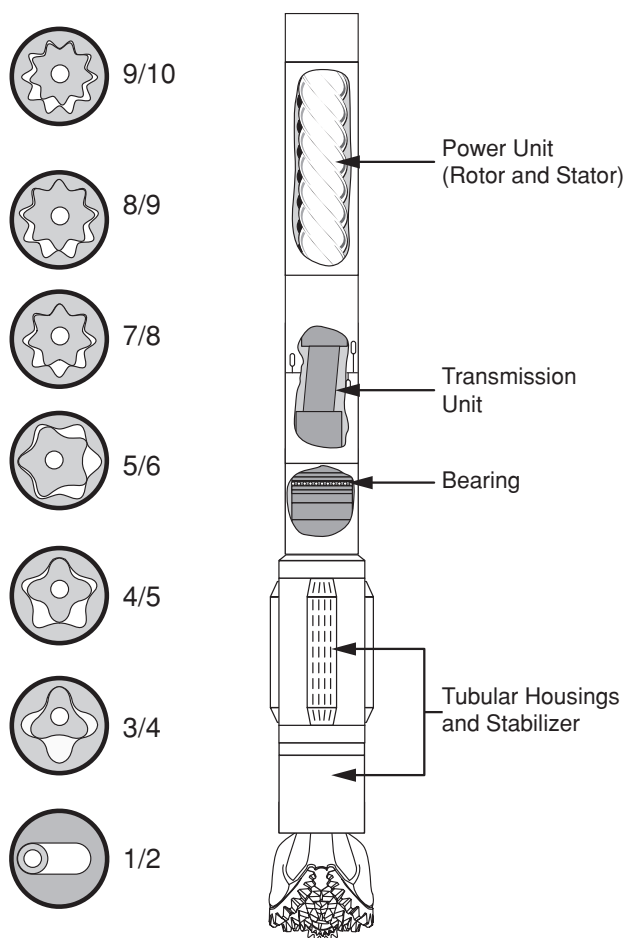

Figure 14 PDM assembly

One effect which must be taken into account when drilling with a downhole motor is *reactive torque*. This is the tendency for the drillstring to turn in the opposite direction from the bit. As the rotor turns to the right, the stator is subjected to a left-turning force. Depending on the type of formation and length of string the drillpipe will twist, causing the bit to drill to the left. This left hand torque will increase as more WOB and pump pressure are applied. The directional driller must allow for this effect when he orients the bent sub. This is largely a matter of field experience in a particular area.

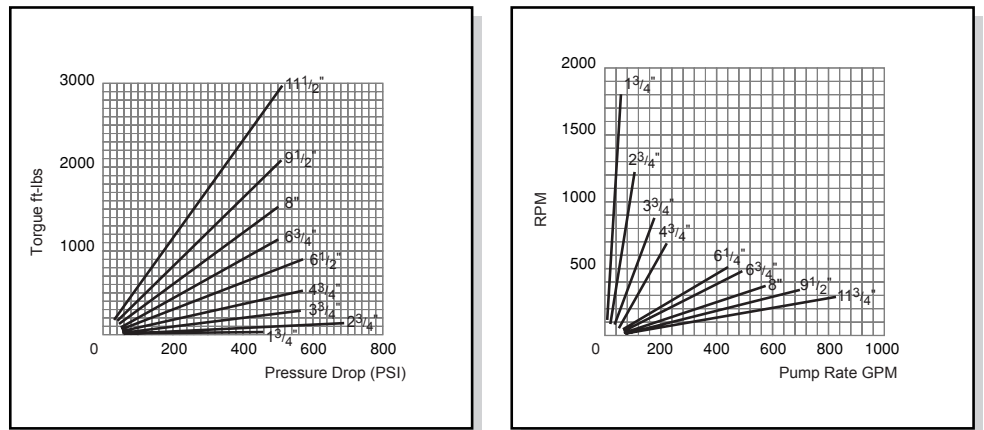

Figure 15 Typical Performance Specification for a PDM

B. TURBODRILLS

This is another type of mud motor which turns the bit without rotating the drillstring. Unlike a PDM a turbodrill can only be powered by a liquid drilling fluid. The turbodrill motor consists of bladed rotors and stators mounted at right angles to fluid flow. The rotors are attached to the drive shaft, while the stators are attached to the outer case. Each rotor-stator pair is called a stage; a typical turbodrill may have 75-250 stages. The stators direct the flow of drilling fluid onto the rotor blades, forcing the drive shaft to rotate clockwise (Figure 16). Turbodrills can be used for directional drilling in much the same way as PDMs. Turbodrills are also used in straight-hole

drilling as an alternative to rotary drilling. Such a technique has the following advantages:

- (a) String and casing wear reduced
- (b) Lower torque applied to string
- (c) Higher RPM at bit (better penetration rates).

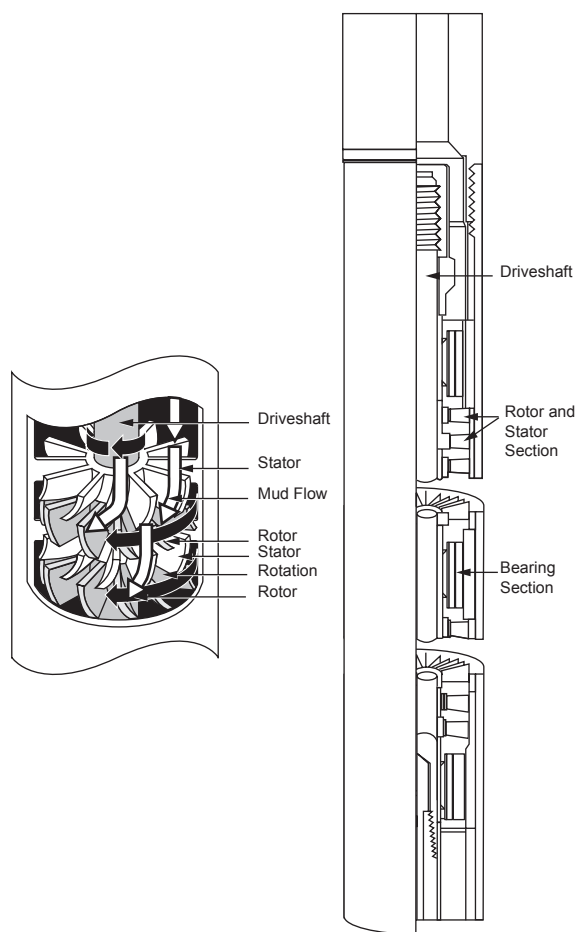

Figure 16 Turbodrill

Turbodrills are sometimes used with PDC (polycrystalline diamond compact) bits in North Sea wells to reduce costs in long bit runs. A typical turbodrill assembly for North Sea use is given in Figure 17.

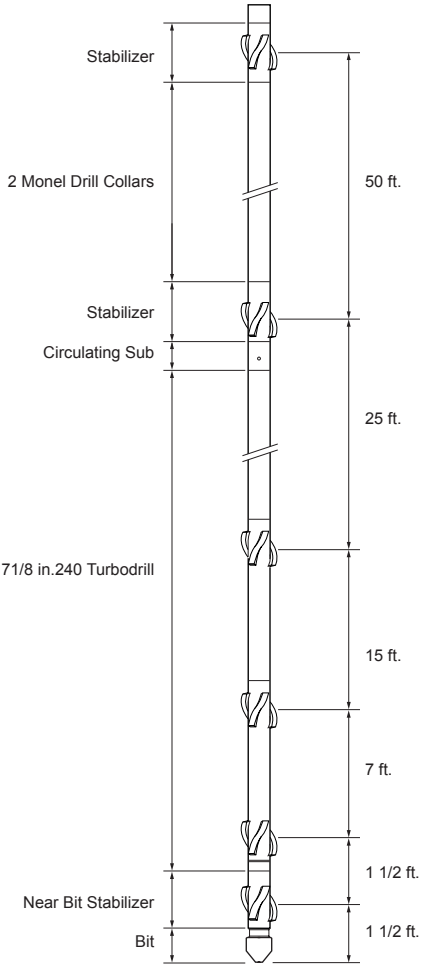

Figure 17 Turbodrill assembly

Solutions to Exercises

Exercise 1 Designing a Deviated Well

The sidetracking of a well requires some preparatory work for the abandonment of the original well but is in essence the same as drilling a deviated well. The solution for this case is given below.

Table Solution 1 presents the results of the design calculations for the sidetrack carried out on a spreadsheet. It also presents the results for the situation which would arise if the buildup angle were increased from 1.5 to 3 degrees per 100ft. It can be seen that increasing the BUR does not significantly affect the along hole depth or the drift angle of the sidetrack. These calculations were carried out on a spread sheet and such sensitivity analysis should be carried out routinely in order to assess the optimum combination of KOP, BUR and drift angle to achieve the objective.

(NOTE: There are some differences in the results of the hand calculation and the spreadsheet due to rounding errors)

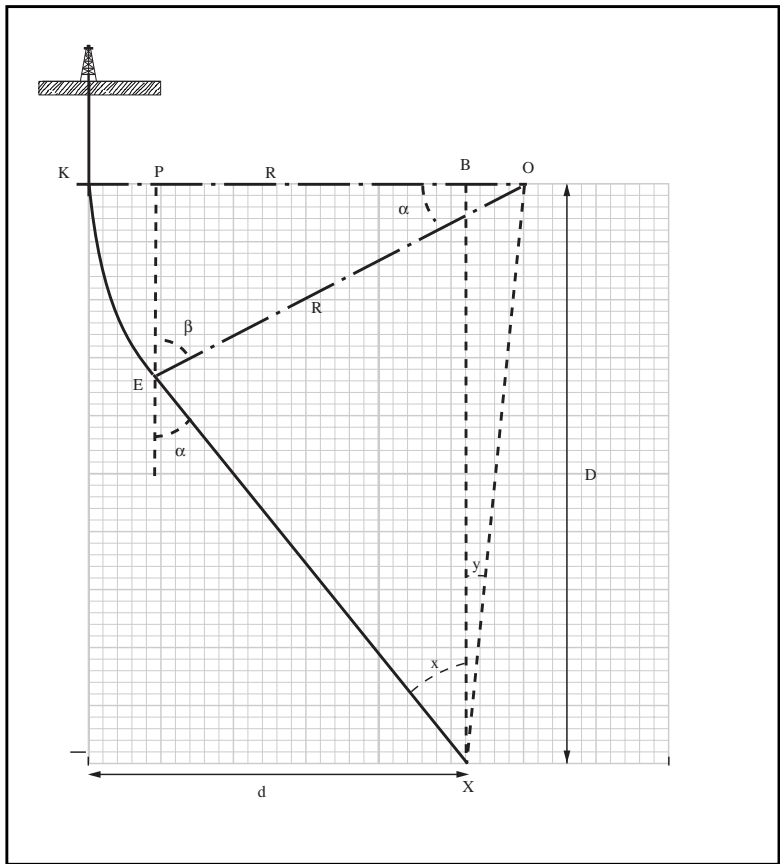

a. Drift Angle:

$$\frac{1.5R}{100} = \frac{360}{2\pi}$$

$$R = \frac{360 \times 100}{3.0 \times \pi} \text{ (Radius of BU section)}$$

$$= 3820 \text{ ft}$$

$$(i) \tan y = \frac{3820 - 3500}{8500} = \frac{320}{8500}$$

$$y = 2.16^\circ$$

$$(ii) \sin y = \frac{3820 - 3500}{OX} = \frac{320}{OX}$$

$$OX = 8490.3 \text{ ft}$$

$$(i) \sin(x + y) = \frac{R}{OX}$$

$$= \frac{3820}{8490.3}$$

$$\sin(x + y) = 0.4499$$

$$(x + y) = 26.74^\circ$$

$$x = 26.74 - 2.16$$

$$= 24.58^\circ$$

(Drift/Tangent Angle)

b. TVD and Displacement of end of BU Section:

$$\beta = 180 - 90 - x$$

$$= 65.42^\circ$$

$$\cos \beta = 0.416 = \frac{PE}{R}$$



$$PE = 1589 \text{ ft}$$

$$TVD (E) = KOP + PE$$

$$TVD (E) = 3089 \text{ ft} \quad (\text{TVD of End of BU Section})$$

$$\sin \beta = 0.9094 = \frac{PO}{R}$$

$$PO = 3474 \text{ ft}$$

$$\begin{aligned} \text{Displacement (E)} &= KO - PO \\ &= 3820 - 3474 \\ &= 346 \text{ ft} \end{aligned}$$

$$\text{Displacement (E)} = 346 \text{ ft} \quad (\text{Displacement of End of BU Section})$$

c. Total measured Depth of Hole:

$$\text{Total AH depth} = KOP + \text{Length BU Section} + \text{Length Tangent Section}$$

$$\text{Length BU Section} = KE$$

$$\frac{\text{Tangent Angle}}{360} = \frac{KE}{2\pi \times 3820}$$

$$0.0683 = \frac{KE}{24002}$$

$$KE = 1639 \text{ ft}$$

$$\text{Total AH} = 1500 + 1639 + EX$$

$$\begin{aligned} EX &= OX \cos (x + y) \\ &= 8490 \times 0.8931 \\ &= 7582 \text{ ft} \end{aligned}$$

$$\text{Total AH depth} = 10721 \text{ ft} \quad (\text{Total measured Depth})$$

	CASE1	CASE2	CASE3
KOP	1500	1500	1500
TVD TARGET	10000	10000	10000
DISPLACEMENT OF TARGET	3500	3500	3500
BUILDUP RATE	1.5	2	3

RESULTS :

RADIUS OF BUIDUP ARC	3819.72	2864.79	1909.86
DRIFT ANGLE	24.53	23.91	23.36
AHD END BUILDUP	3135.29	2695.65	2278.52
TVD END BUILDUP	3085.79	2661.24	2257.14
DISPLACEMENT AT END BUILDUP	344.73	245.91	156.49
AH DEPTH TARGET	10735.42	10723.51	10712.44

Table Solution 1 Planned Trajectory for a Deviated Well

Directional Surveying **12**

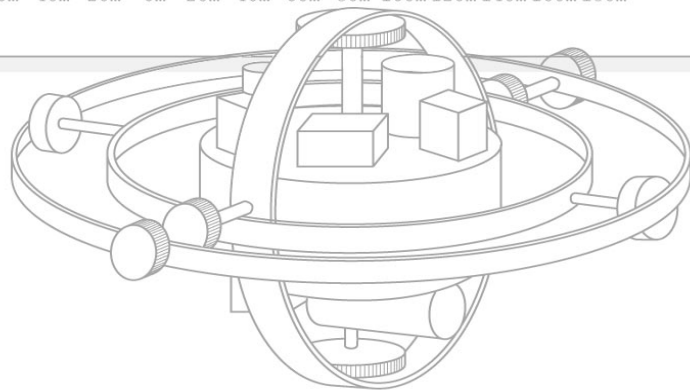
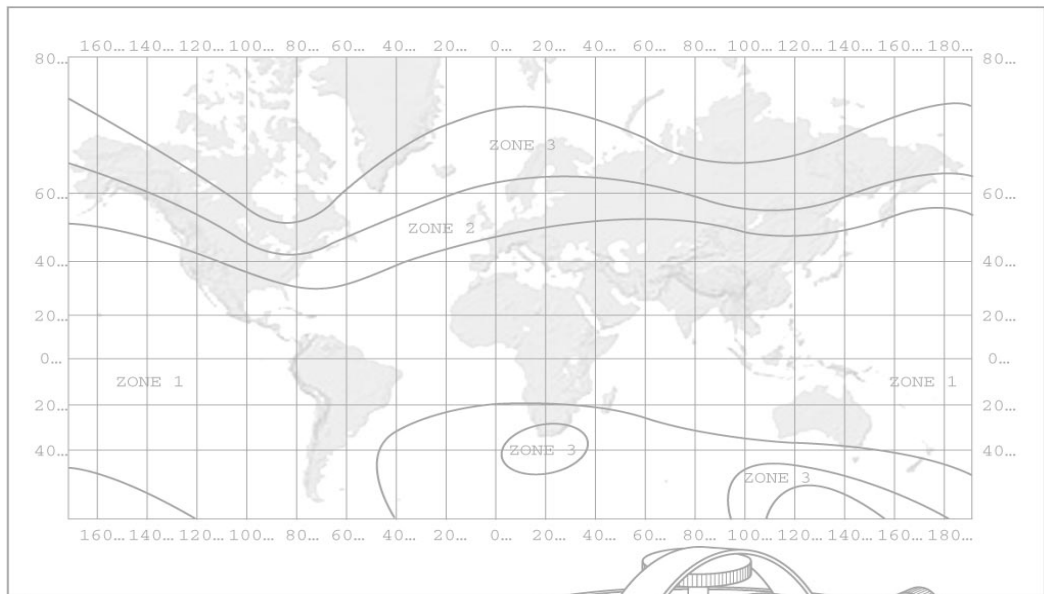

CONTENTS

1. INTRODUCTION
2. SURVEYING CALCULATIONS
 - 2.1 Principles of Surveying
 - 2.2 Wellbore Surveying
 - 2.3 Position of the Reference Point
 - 2.4 Measured Depth of Survey
 - 2.5 Azimuthal Direction of Wellbore
 - 2.6 Inclination of the wellbore
 - 2.7 Mathematical Models of the Wellbore Trajectory:
 - 2.7.1 Tangential Model
 - 2.7.2 Balanced Tangential Model
 - 2.7.3 Average Angle Model
 - 2.7.4 Radius of Curvature Model
 - 2.7.5 Minimum Curvature Model
3. SURVEY CALCULATIONS AND PLOTTING RESULTS
4. PHOTOGRAPHIC SURVEYING TOOLS
 - 4.1 Magnetic Single Shot
 - 4.2 Magnetic Multi-shot
 - 4.3 Gyro Single Shot
 - 4.4 GyroMulti-Shot
 - 4.5 Accuracy of Photographic Survey Results
5. DOWNHOLE TELEMETRY TOOLS
6. INERTIAL NAVIGATION SYSTEMS
7. STEERING TOOLS





LEARNING OBJECTIVES

Having worked through this chapter the student will be able to:

General:

- List and describe the reasons for conducting well surveys.

Surveying Techniques:

- Describe the construction and operation of a magnetic single shot.
- Describe the construction and operation of a magnetic multi-shot.
- Describe the construction and operation of a gyroscopic single shot.
- Describe the construction and operation of a gyroscopic multi-shot.
- Describe the component parts of an MWD system.
- Describe the component parts and method of operation of an inertial navigation system.

Deflection Tools:

- Describe the component parts and the mode of operation of a steering tool system.

Survey Calculations:

- Describe the mathematical models used to describe and calculate the well trajectory: Tangential; balanced tangential; average angle; radius of curvature; and minimum curvature.
- Describe the procedure used to calculate and plot survey results.
- Calculate the northing, easting, TVD, vertical section and dogleg severity of a survey station using the average angle method.

1. INTRODUCTION

When drilling a directional well, the actual trajectory of the well must be regularly checked to ensure that it is in agreement with the planned trajectory (Figure 1). This is done by surveying the position of the well at regular intervals. These surveys will be taken at very close intervals (30') in the critical sections (e.g. in the build-up section) of the well. Whilst drilling the long tangential section of the well, surveys may only be required every 120'. The surveying programme will generally be specified in the drilling programme. If it is found that the well is not being drilled along its planned course, a directional orientation tool must be run to bring the well back on course. In general the earlier such problems are recognised the easier they are to be corrected. Surveying therefore plays a vital role in directional drilling.

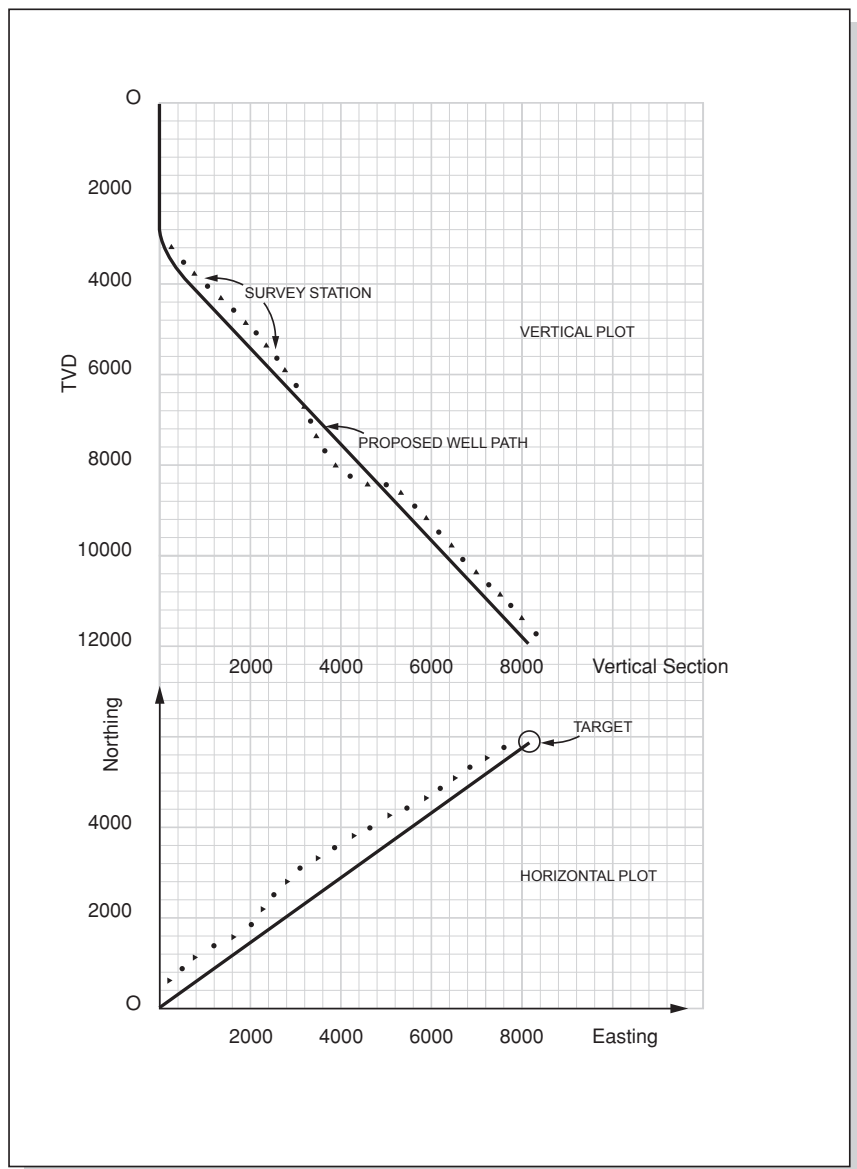

Figure 1 Proposed and Actual Trajectory of a well

2. SURVEYING CALCULATIONS

The principles used in surveying a wellbore are the same as those used in land surveying.

2.1 Principles of Surveying

The basic principles of surveying can be illustrated by considering the two dimensional system shown in Figure 2. The position (co-ordinates) of point, B relative to the reference point A can be determined if the angle α and the distance AB is known. If the position of point A is defined as 0,0 in the X, Y co-ordinate system the position of point B can be determined by the following equations:

$$Y_B = AB \sin \alpha$$

$$X_B = AB \cos \alpha$$

Hence the displacement of point B in the X and Y direction can be determined if the angle α and the linear distance between A and B are known. The position of a further point C can be determined by the same procedure. The X and Y displacement of C relative to the reference point A can be determined by adding together the X and Y displacement of Point B to A and those of Point C to B. This process of defining the position of a point relative to a specific reference point can be continued for any number of points.

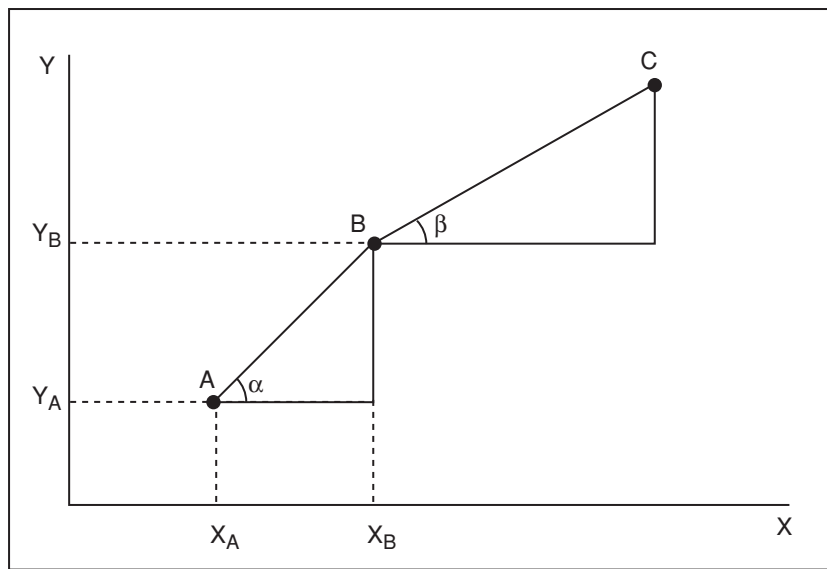

Figure 2 Basic Principles of Surveying

2.2 Wellbore Surveying

This same principle as that above is applied to wellbore surveying. In the case of wellbore surveys however the procedure must include consideration of the following:

- The process must be applied in three dimensions
- The trajectory between the survey points (the path of the wellbore) is not generally a straight line

The three dimensional aspect of the problem is not a significant issue since the same process as that outlined above can be applied to the vertical displacement as well as the horizontal displacement of the survey points (stations). The procedure is described below in section 2.7. The fact that the trajectory of the wellbore is not generally defined by a straight line is accommodated by assuming that the trajectory of the wellbore follows a simplified geometrical model. The only information that is required to determine the co-ordinates of all points in the well trajectory are therefore:

- The position of the initial, reference point (generally the Rotary Table)
- The measured depth (AHD) of the survey station
- The direction (Degrees from North) in which the wellbore is oriented at the survey station
- The inclination (Degrees from the vertical) of the wellbore at the survey station
- A mathematical model of the wellbore trajectory

2.3 Position of the Reference Point

The depth referencing system used when surveying was discussed extensively in chapter 11.

2.4 Measured Depth of Survey

The depth of the survey station is provided by the the driller and is calculated on the basis of the length of drillstring in the wellbore and the distance between the drillbit and the survey tool.

2.5 Azimuthal Direction of Wellbore

The direction in which the drillbit is pointing when a survey is taken is expressed in degrees **azimuth**. Azimuth is the angle in degrees (°) between the horizontal component of the wellbore direction, at a particular point, measured in a clockwise direction from the reference (generally North). Azimuth is generally expressed as a reading on a 0 - 360° (measured from North) scale.

For directional surveying, there are three azimuth reference systems :

- Magnetic north;
- True (Geographic) North;
- Grid North.

Magnetic North (MN)

This is the direction of the horizontal component of the Earth's magnetic field lines at a particular point on the Earth's surface. A magnetic compass will align itself to these lines with the positive pole of the compass indicating North.



True (Geographic) North (TN)

This is the direction of the geographic North Pole. This lies on the axis of rotation of the Earth. The direction is shown on maps by the meridians of longitude.

Grid North (GN)

The meridians of longitude converge towards the North Pole and South Pole, and therefore do not produce a rectangular grid system. The grid lines on a map form a rectangular grid system, the Northerly direction of which is determined by one specified meridian of longitude. The direction of this meridian is called Grid North. For example, in the often used **Universal Transverse Mercator (UTM)** co-ordinate system the world is divided into 60 zones of 6 degrees of latitude, in which the central meridian defines Grid North. Grid North and True North are only identical for the central meridian. Comparison of co-ordinates is only valid if they are in the same grid system.

To be meaningful, all azimuths must be quoted in the same reference system. This is usually the Grid North system. In practice, azimuths are often measured in systems other than the Grid North system. Two conversions normally have to be applied to the measured azimuths:

Grid Convergence

Grid convergence converts azimuth values between the Grid North and the specified True North system. The grid convergence angle is the angle between the meridians of longitude (TN) and the North of the particular grid system (GN) at a given point. By definition, the grid convergence is positive when moving clockwise from True North to Grid North, and negative when moving anti-clockwise from True North to Grid North. The value of grid convergence depends upon location. Close to the Equator the convergence is small and it increases with increasing latitude.

Declination

Declination converts azimuth values between the Magnetic North and True North systems. Declination is the angle between the horizontal component of the Earth's magnetic field lines and the lines of longitude. By definition, the declination is positive when moving clockwise from True North to Magnetic North, and negative when moving anti-clockwise from True North to Magnetic North. Values of declination change with time and location and those representative of the parameters at the time of drilling should be used.

2.6 Inclination of the wellbore

The inclination of the wellbore is the angle in degrees that the wellbore is deviated from the vertical.

2.7 Mathematical Models of the Wellbore Trajectory:

The geometrical models that are used to represent the trajectory of the wellbore are:

2.7.1 Tangential Model

This model uses only the angles of inclination and direction measured at the lower survey station. The wellbore path is assumed to be tangential to these angles throughout the survey interval (Figure 3). The larger the angle, and the greater

the survey interval, the more inaccurate the results from this model. This model is highly inaccurate and is not recommended.

2.7.2 Balanced Tangential Model

This model uses the survey data from both the upper and lower stations. The model assumes that the well path lies along two equal length, straight line segments. The inclination and direction of each segment is given by the corresponding survey station. The tangential model is therefore applied twice - once to the upper half, once to the lower half (Figure 4). This model approximates more closely to the probable shape of the wellbore and yields more accurate results (especially if the angles are changing rapidly).

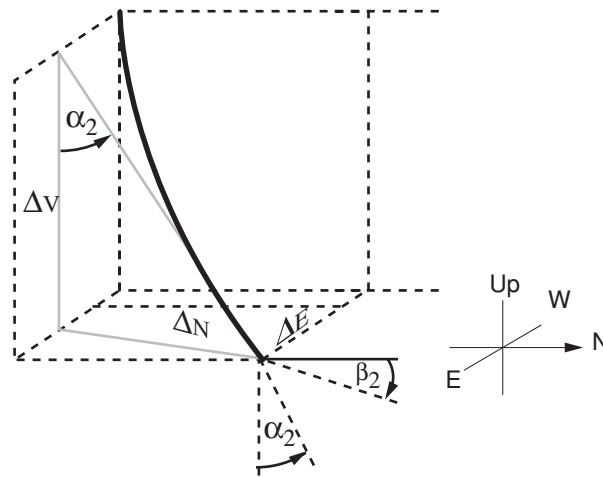

Figure 3 Tangential Model

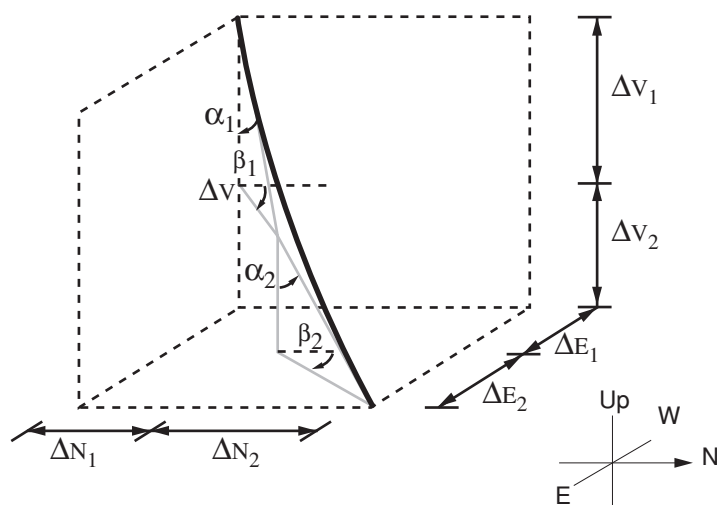

Figure 4 Balanced Tangential Model

2.7.3 Average Angle Model

In this model the inclinations and the directions at the two survey stations are averaged. The wellbore is then assumed to be one straight line over the survey interval having this average direction and inclination. This straight line path is a good approximation provided the survey interval is small, and the rate of curvature is small in the actual wellbore (Figure 5). This model is often used at the rig site since the calculations are fairly simple.

2.7.4 Radius of Curvature Model

This model assumes a curved path which has the shape of a spherical arc passing through the measured angles at the two survey stations (Figure 6). Essentially, the inclination and direction are assumed to vary linearly over the course length. This method is less sensitive to errors, even if the survey interval is relatively long. The calculations however, are complicated and are best handled by computer.

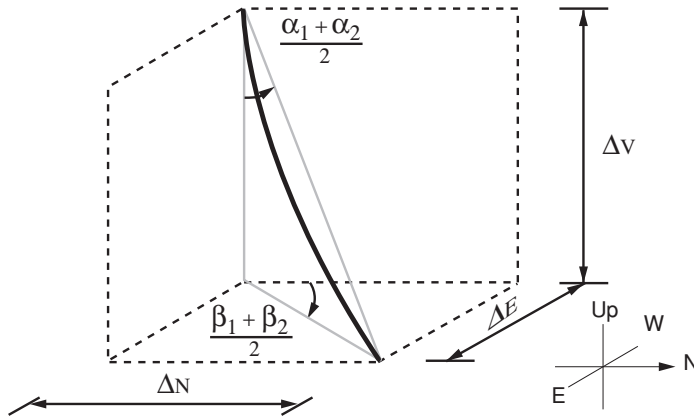

Figure 5 Average Angle Model

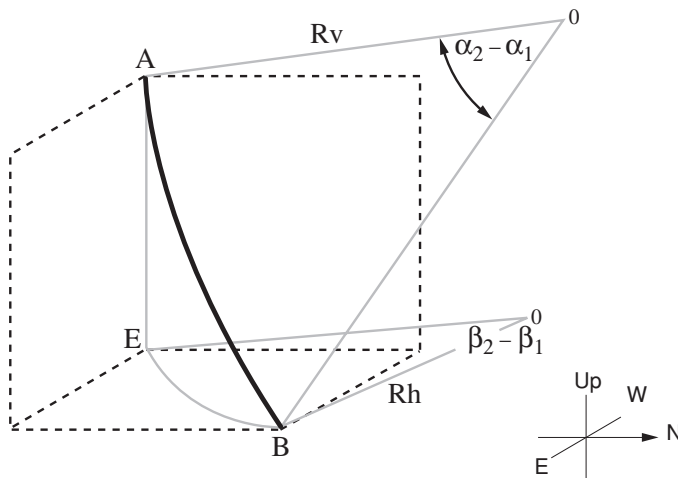

Figure 6 Radius of Curvature Model

2.7.5 Minimum Curvature Model

This model takes the space vectors defined by inclination and direction measurements and smooths these onto the wellbore curve (Figure 7). The curvature of the path is calculated using a ratio factor, defined by the dog-leg of the wellbore. The result of minimising the total curvature within the physical constraints of the wellbore is an arc. Again the calculations are best handled by computer.

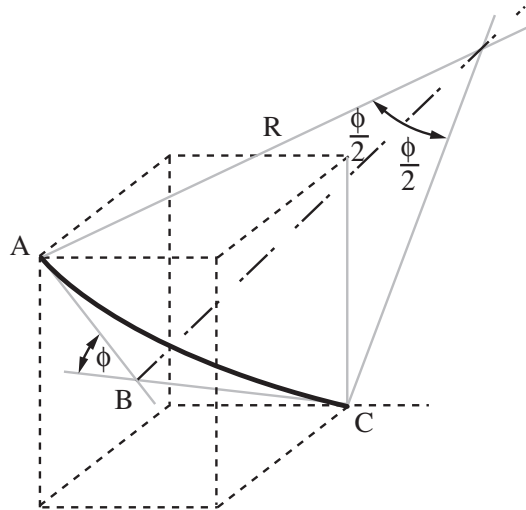

Figure 7 Minimum Curvature Model

3. SURVEY CALCULATIONS AND PLOTTING RESULTS

A description of directional well profile planning was given in chapter 11. Large scale plots, drawn by computer, are normally available to show the trajectory of the well. Both vertical and horizontal plots are used (Figure 1). The purpose of having these plans is to allow the engineers to plot the actual position of the well as it is being drilled. By carrying out this exercise they can detect any serious difference between the planned path and the actual path. It is also used to plan any correction run that must be made. When drilling from a multi-well platform it is useful to have plans showing the position of adjacent wells also.

The purpose of all the calculations described above is to fix the co-ordinates of the wellbore on a horizontal and vertical plan. On a single well, all depths are initially referenced to the rotary table. On a multi-well platform the co-ordinates of the survey stations in all of the wells will then be referenced to the same reference point so that comparisons with adjacent wells can easily be made. The reference point is usually the centre of the drilling template or wellhead area.

The steps involved in calculating and plotting the position of the survey stations are as follows:



a. Calculate the position of the survey station:

The vertical and horizontal (in the Northerly and Easterly direction) displacement of the survey station from the previous station is calculated using one of the models discussed in section 2.7 above.

b. Calculate the displacement of the station in the vertical section:

A particular line along which the well displacement can be measured and represented must be selected. The obvious line to choose from is the wellhead reference point to the target. This is sometimes called the **Target Bearing**. Once the N and E co-ordinates of the new survey station are fixed the true horizontal distance from the survey station back to the reference point can be calculated (closure). This distance must then be projected onto the target bearing. The distance measured along the target bearing to this point is known as the **vertical section** (i.e. the section measured along a vertical plane containing the reference point and the target). Having calculated the TVD and the vertical section for each survey station the position of the well can be plotted on the vertical plane.

c. Calculate the dogleg severity of the section:

Another parameter that is always calculated is the **dog-leg severity**. The Dog-leg severity is the total three dimensional angular change between stations and can be calculated as shown in Figure 8. Usually the operating company will place some limit on the amount of bending which can be allowed between survey stations (e.g. 5 degrees/100'). This will ensure that casing and downhole tools can be run without getting stuck. It is therefore important to monitor the dog-leg severity at each survey station. The dog-leg severity (DLS) is obtained by dividing the change in angle by the course length between the stations, and then multiplying by 100. The dog-leg severity (DLS) is then obtained by dividing the change in angle by the course length between the stations, and then multiplying by 100.

To derive the formula to calculate the dog-leg angle consider the survey stations shown in Figure 8. At the upper station the inclination and azimuth have been measured as α_A and β_A . At the lower station the corresponding angles are α_B and β_B . These angles define the two straight line segments whose lengths are L_1 and L_2 . The change in total angle (ϕ) between these two segments is shown as in the diagram. The size of the angle ϕ can be determined by considering the triangle bounded by the lines L_1 , L_2 and L_3 .

$$\begin{aligned} \text{Dog leg angle} &= \cos^{-1}\{\cos\alpha_A \cos\alpha_B + \sin\alpha_A \sin\alpha_B \cos(\beta_A - \beta_B)\} \\ &= \cos^{-1}\{\cos 5^\circ \cos 8^\circ + \sin 5^\circ \sin 8^\circ \cos(145^\circ - 135^\circ)\} \\ &= 3.2 \end{aligned}$$

If the measured depth between A and B is 90ft, then the dog leg severity is given by:

$$\text{DLS} = \frac{3.2}{90} \times 100 = 3.6^\circ \text{ per } 100'$$

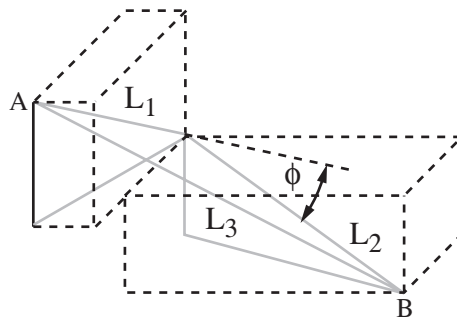

Figure 8 Dog-leg angle

4. PHOTOGRAPHIC SURVEYING TOOLS

The oldest surveying instrument was known as an **acid bottle**. When taking a survey the tool aligned itself with the axis of the hole but the surface of the acid remained level. The instrument was left in this position for about 30 minutes, allowing the acid to etch a sharp line on the glass container which indicated the hole angle. This system did not however determine the direction of the wellbore.

Surveying tools have been used in directional wells since the 1930's. The most simple tools consist of an instrument that measures the inclination and N-S-E-W direction of the well. A photographic disc contained within the instrument is used to produce an image of the surveying instrument. When the instrument is brought back to surface the disc is developed and the survey results recorded. There are 3 methods of running and retrieving the photographic instrument:

- It may be run and retrieved on wireline (sandline)
- It may be dropped down the drillpipe, then retrieved by running an overshot on wireline
- It may be dropped free down the drillpipe and retrieved when a trip is made (e.g. to change the bit). When the instrument reaches bottom it sits inside a baffle plate called a **Totco ring** which holds the instrument in position.

4.1 Magnetic Single Shot

The magnetic single shot was first used in the 1930's for measuring the inclination and direction of a well. The instrument consists of 3 sections:

- An angle unit consisting of a magnetic compass and an inclination measuring device.
- A camera section
- A timing device or motion sensor unit

The angle unit of the tool consists of a magnetic compass and a plumb bob (Figures 9 and 10). When the tool is in the correct position (near the bit) the compass is allowed to rotate until it aligns itself with the Earth's magnetic field. The plumb bob

hangs in the vertical position irrespective of how the instrument may be deviated in the hole.

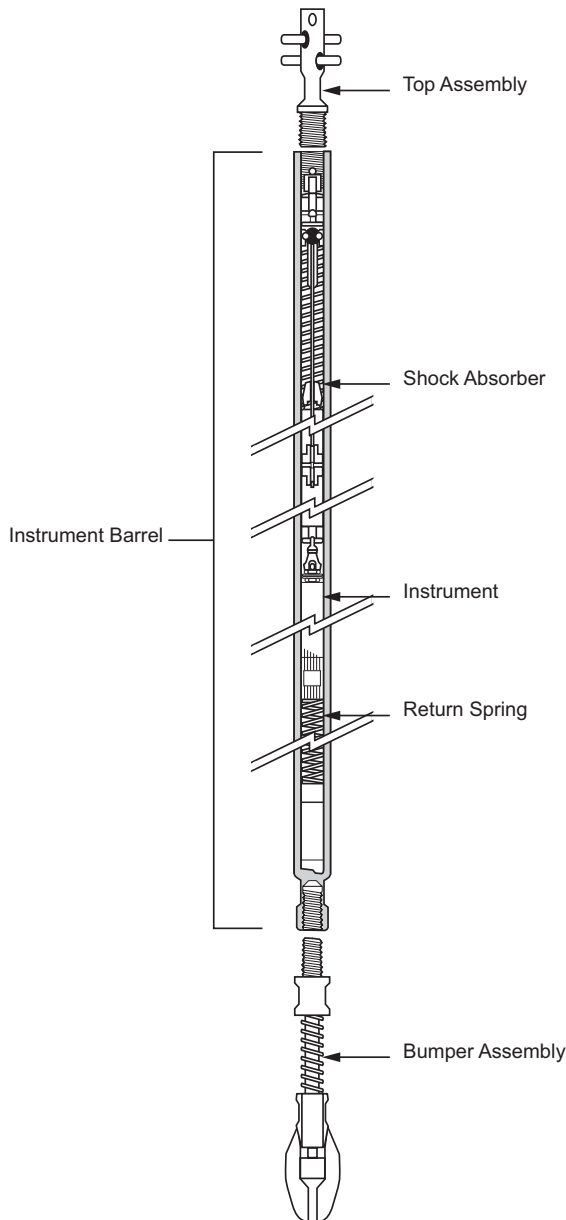

Figure 9 Magnetic Single Shot Device

The camera consists of a photographic disc, which is mounted in the tool in a lightproof loading device, a set of bulbs which are used to illuminate the angle unit, when required, and a battery unit, which provides power to the light bulbs.

The timing device is used to operate the lightbulbs when the instrument is in the correct position. The surveyor must estimate the time required to lower the instrument into position and set the timer accordingly. Since it is sometimes difficult to estimate the time required for the tool to reach the bit, more modern instruments

use a motion sensor unit. This electronic device will illuminate the lightbulbs when the instrument stops moving. When the lightbulbs are illuminated a photograph image of the plumb bob is superimposed on the compass card as shown in Figure 11.

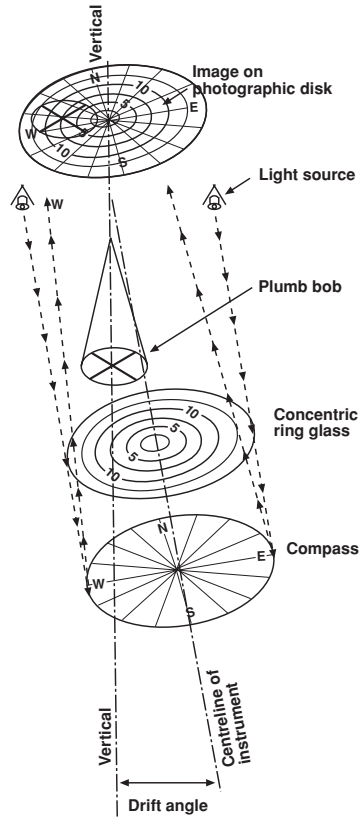

Figure 10 Magnetic Single Shot Instrument

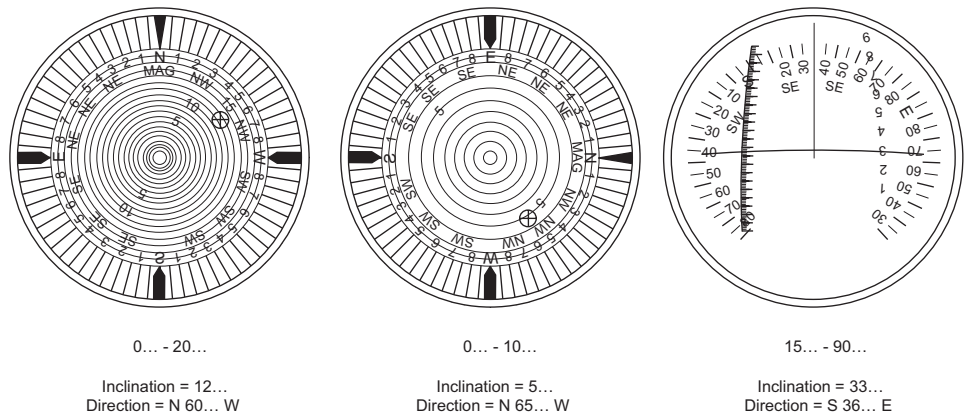

Figure 11 Examples of Compass Displays

4.2 Magnetic Multi-shot

At certain points in the well it is useful to determine the overall trajectory in a single survey run (e.g. just before running casing). This is usually done by a multi-shot instrument which takes a series of pictures. A magnetic multi-shot works on the same principle as a magnetic single shot, but has a special camera unit. A roll of film is automatically exposed and wound on at pre-set intervals (Figure 12).

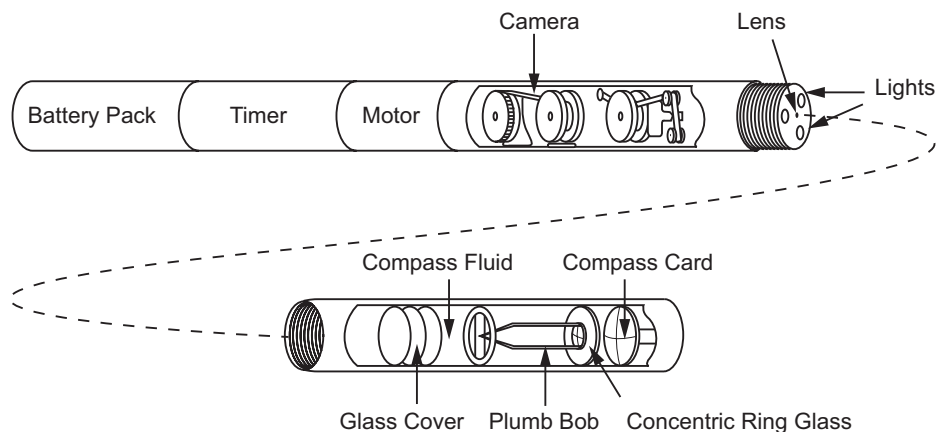

Figure 12 Magnetic Multishot Device

The magnetic multi-shot is either dropped free, or lowered into the non-magnetic collar by wireline. Since the compass must remain within the non-magnetic collar to operate accurately, the multishot survey is taken as the pipe is tripped out of the hole. The directional surveyor must keep track of the depth at which the pre-set timer takes a picture. Only those shots taken at known depth when the pipe stationary will be recorded. When the multi-shot is recovered, the film is developed and the survey results read.

The readings from a magnetic compass will be incorrect if the compass is close to a magnetised piece of steel. Since both the drillstring and casing will be magnetised, as they are run through the earth's magnetic field, the magnetic surveying tools cannot be used unless some measure is taken to ensure that the well direction according to the earth's magnetic field is accurately recorded on the compass. In the case of the drillstring this is done by using non-magnetic drillcollars in the BHA. These collars are made from Monel and the Earth's magnetic field is undisturbed by their presence. An accurate reading of the direction of the well can therefore be obtained. The number of collars that are required depends on the magnetic latitude and hole direction. The compass is actually measuring the horizontal component of the Earth's magnetic field. Where the magnetic field lines are steeply dipping and the hole direction is close to the East-West axis the horizontal component is small, and so more non-magnetic collars must be used (Figure 13). Since steel casing also becomes magnetized this type of survey cannot be run in cased holes.

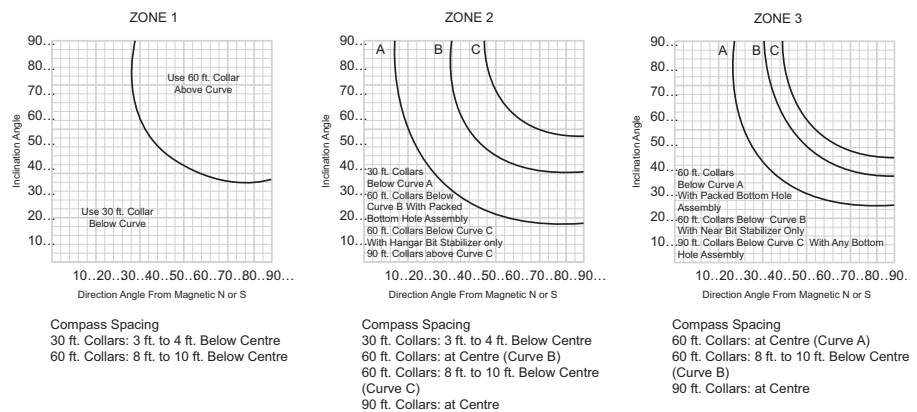
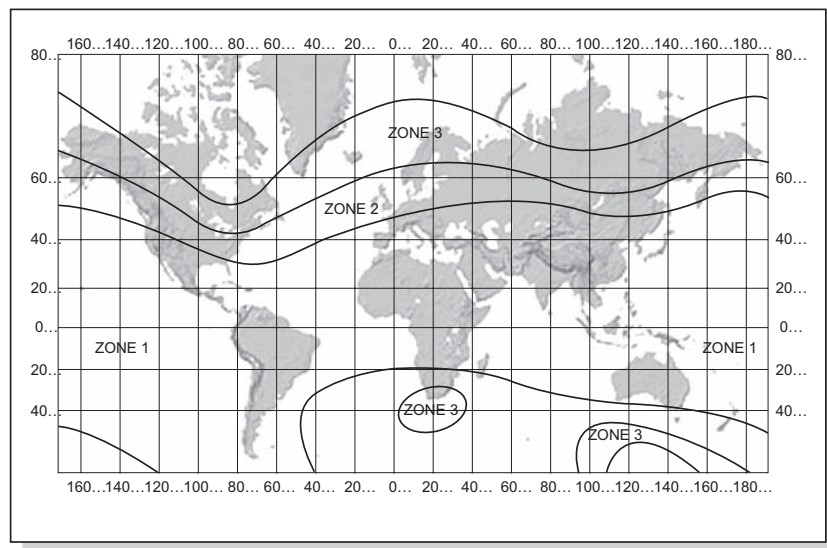

Figure 13 Influence of Well Position on Requirement for Drill collars

4.3 Gyro Single Shot

Since magnetic surveys which rely on compass readings are unreliable in cased hole, or in open hole where nearby wells are cased, an alternative method of assessing the direction of the well must be used. The inclination of the well can be assessed in the same way as in the magnetic tools. The Magnetic effects can be completely eliminated by using a gyroscopic compass.

A gyroscope is a wheel which spins around one axis, but is also free to rotate about one or both of the other axes, since it is mounted on gimbals. The inertia of the spinning wheel tends to keep its axis pointing in one direction. In a gyro single shot tool, a gyroscope is rotated by an electric motor at approximately 40,000 rpm. On surface the gyro is lined up with a known direction (True North) and as the tool is run in hole the axis of the tool should continue to point in the direction of true North regardless of the forces which would tend to deflect the axis from a northerly direction. A compass card is attached to, and aligned with, the axis of the gyroscope and this acts as the reference direction from which all directional surveys are taken. Once the tool has landed in the required position in the drill collars the procedure is



very similar to that for the magnetic single shot. Since the compass card is linked to the axis of the gyroscope it records a True North bearing which does not require correction for magnetic declination.

Gyroscopes are very sensitive to vibration so the gyro single shot must be run and retrieved on wireline. The gyroscope may also drift away from its set direction while it is being run in the hole. When the instrument is recovered therefore, its alignment must be checked, and a correction applied to the readings obtained from the survey. Gyro single shots are often used to orient deflecting tools near casing.

The Gyro Multi-Shot is used in cased holes to obtain a series of surveys along the length of the wellbore. The magnetic multi-shot cannot be used because of the interference to the earth's magnetic field, caused by the magnetisation of the casing. The directional surveyor must keep track of the depth at which the pre-set timer takes a picture. Only those shots taken at known depth when the pipe stationary will be recorded. When the multi-shot is recovered, the film is developed and the survey results read. In the case of both single shot and multi-shot instruments adequate centralization must be provided so that the instrument is properly aligned with the wellbore.

4.5 Accuracy of Photographic Survey Results

There are two particular sources of error to be recognised when using photographic instruments:

- Instrument error - due to the inaccuracy of the device itself, infrequent calibration and damage caused to the instrument.
- Reader error - the developed film is easily mis-read. Some discs may have to be magnified to be read properly. Readings should be verified by another person (although this is seldom the case on the rig). Under ideal conditions (i.e. selecting correct angle unit, non-magnetic collars, centralization of tool etc.) inclination is accurate to ± 0.25 degrees, and direction to ± 2 degrees.

5. DOWNHOLE TELEMETRY TOOLS

Surveying using photographic instruments is relatively simple and cheap (in terms of the cost of running the tools). There is however, the cost of the rig-time while the survey is being run. During this period the drillpipe will be stationary in the open hole at some point and there is therefore the possibility of the pipe becoming stuck. The longer the pipe remains stationary in the hole, the greater chance of getting stuck. To avoid stuck pipe some time is spent circulating to condition the hole prior to running the survey and the drillstring will be reciprocated whilst the survey tool is being run (or is dropping) down the drillstring. It is now possible to provide the directional driller with a real-time surface read-out (i.e. a system which will give him the survey data while the well is being drilled) from a measurement whilst Drilling (MWD) System (Figure 14). Although this involves more complicated tools, for which a higher rental cost will be incurred, it can be more cost-effective in the long run since it is not necessary to stop drilling whilst the survey tools are being run in and pulled from hole (approximately 2 hrs in a 10,000 ft well).

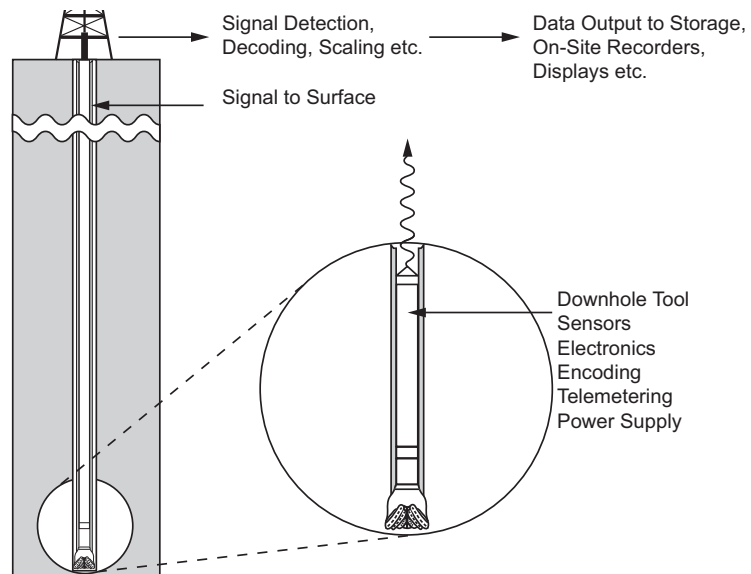

Figure 14 Telemetry Surveying Techniques

MWD tools are discussed at length in chapter 13 but basically they consist of a downhole measuring unit built into a length of pipe which is similar to a drillcollar, a telemetry system and a surface read-out unit. Different telemetry methods may be used to transmit the information from downhole to surface. Some use a conducting wireline (steering tools) while others transmit signals through the mud column (MWD). The downhole measuring devices used may be gyroscopes, magnetometers or accelerometers. The disadvantage of gyroscopes is their tendency to drift off line and the risk of damage due to vibration during drilling. Magnetometers are more rugged instruments which measure the intensity and direction of the Earth's magnetic field. An accelerometer measures the Earth's gravitational field. Instead of taking photographs these instruments measure inclination and direction electronically and transmit results to the surface read-out unit. These tools are of great importance to the directional driller since they provide a great deal more directional information than the more discrete survey tools run on wireline. This extra data greatly assists the decisions-making regarding the course of the well.

6. INERTIAL NAVIGATION SYSTEMS

Inertial navigation is a very precise method of surveying used in aircraft and missile guidance systems. In the late 1970s this technique was adopted for borehole surveying in the North Sea. The FINDS tools (Ferranti Inertial Navigation Directional Surveyor) based on an inertial platform consisting of 3 accelerometers and 3 gyroscopes mounted on gimbals was the first IN system used in borehole surveying.

Although the FINDS tool is no longer used it is the most generic type of tool and will therefore be described. On the surface the platform is automatically levelled and the N-S accelerometer aligned with true North. As the tool is run down the hole



on wireline any misalignment of the platform is detected by the gyroscopes which send signals to the gimbal mechanism to restore the platform to its original position. The running procedure is to stop the tool for 1 minute, then run for 1 minute and so on until it reaches bottom. During the 1 minute transit periods the accelerometer readings give the inertial velocity. Once back on surface this data can be integrated to give the incremental X, Y and Z displacements for each transit period. These distances can then be added to the previous co-ordinates to give the trajectory of the cased borehole (Note that the FINDS tool calculates the co-ordinates directly, not by measuring azimuth and inclination). The FINDS tool was generally considered to be the most accurate surveying device available. Its accuracy was about 0.2 ft. per 1000 ft. of hole length (i.e. it can locate a 13 5/8" casing shoe, set at 5000 ft, to within 1 foot, compared with 15 - 30 ft. using conventional gyro methods).

The FINDS tool does however have certain disadvantages :

- The tool diameter was 10 5/8", and so could only be used down to the 13 3/8" casing shoe.
- It is much more expensive to run than a gyro multi-shot.
- Only a limited number of tools were available.

Its major application was to provide a definitive trajectory of the hole from surface down to the 13 5/8" casing shoe. High accuracy is required here when drilling from multi-well platforms where the wells are very close to each other and there is a risk of intersection.

Since the FINDS tool a number of new surveying tools were introduced. In 1981 Schlumberger, introduced the GCT (Guidance Continuous Tool). This instrument is only 3 5/8" diameter and it can therefore be used to survey the entire well path down to TD (minimum casing size is 4 1/4"). The inertial platform in the GCT consists of a 2 axis accelerometer and a 2 axis gyroscope, mounted on gimbals. The spin axis of the gyroscope is parallel with one axis of the accelerometer and aligned with true North. Any drift of the gyro is detected by positional sensors and corrected by the gimbal mechanism. The inclination and azimuth are calculated from the accelerometer reading and the angle between the outer and inner gimbals. The inclination and azimuth are given on a surface display as the tool is being run. The survey depth is given by the wireline measurement. The accuracy of this tool is about 2.6 ft. per 1000 ft. of hole length, in the North Sea.

7. STEERING TOOLS

Orienting deflecting tools by the methods, is very time consuming. Furthermore the deflecting tool may not give the expected dog-leg under practical conditions so that the next survey may show some unexpected results. Much of the uncertainty is removed by using a kind of telemetry surveying method. The kind of tools specifically designed to orientate deflecting tools and monitor the well's progress during a correction run are known as "steering tools". A steering tool is a wireline telemetry surveying instrument which measures inclination and direction while drilling is in progress. The use of a wireline to send signals to surface means that the drillstring cannot be allowed to rotate. Steering tools can only be used when a mud motor is being used to make the correction run.

The downhole component of the steering tool is called a probe which continuously measures hole direction and the position of the toolface. This data is sent via the wireline to a surface unit which gives a numerical read-out and may also give a circular dial showing the orientation of the toolface with respect to the High side of the hole. This is of particular value to the directional driller because he can see how the toolface is changing (due to geological effects or reactive torque) as the well is being drilled. If the toolface must be changed by rotating the pipe the steering tool will give the new heading instantaneously. This makes the orienting procedure very much simpler and saves a lot of time. The directional driller can use the steering tool to make the well build or drop, turn to left or right depending on the orientation of the toolface shown on the surface dial. The steering tool allows the directional driller to see exactly what is happening downhole.

An orienting sub with an adjustable key is made up above the bent sub. The key is aligned with the scribe line of the bent sub. A non-magnetic drill collar is made up on top of the orienting sub. Once the BHA is run in the hole a circulating head with a wireline pack off is installed on top of drillstring. The steering tool with a “muleshoe stinger” on the end of it is lowered on a single conductor wireline until it engages the key in the orienting sub, thus aligning the probe with the toolface.

The probe remains in this position while the pumps operate the downhole motor and drilling proceeds. The probe continuously monitors the course of the hole and orientation of toolface as drilling continues. When a connection is made the probe must be pulled out while a new joint of pipe is made up. Once this has been done the probe is run back in on the wireline and drilling proceeds as before. In order to minimize the time wasted in tripping the probe, connections are only made at every 3 joints (i.e. the circulating head is installed on a stand of drillpipe, and so connections are made at 90' intervals).

A slight modification to the standard steering tool is to run a side-entry sub. This allows the wireline to pass from the drillpipe into the annulus at some point below the rotary table. The purpose of this modification is to allow joints of pipe to be added without pulling the probe. However, care must be taken when making connections since the wireline must pass through openings in the drillpipe slips. (This may also cause problems if a kick occurs and BOPs must be closed on this line. If the BOPs do not seal, the wire will have to be cut). If the drill pipe becomes stuck at some point below the side entry sub a free point indicator cannot be run.

The advantages of using a steering tool as opposed to a photographic instrument for orienting and surveying may be summarised as follows:

- Saves rig time due to:
 - sending results to surface more quickly
 - fewer attempts required to get orientation correct
 - allows a correction run to be completed in shortest possible time.
- Better directional control of well path due to continuous monitoring
- Able to monitor the orientation of deflection tool during drilling.



The main disadvantage is that due to the wireline, steering stools cannot be used in conventional rotary drilling - only with a mud motor.

The next logical step in the advancement of directional surveying was to have a steering tool which did not depend on wireline. Hence the MWD tools - measurement while drilling were developed and used for this purpose.

AVERAGE ANGLE METHOD

This method assumes a straight line between survey stations A and B. The inclinations and directions are averaged. The objective is to calculate the following for the survey point B in the diagram below:

- TVD
- North Co-ordinate
- East Co-ordinate
- Vertical Section (VS)
- Dogleg Severity (DLS)

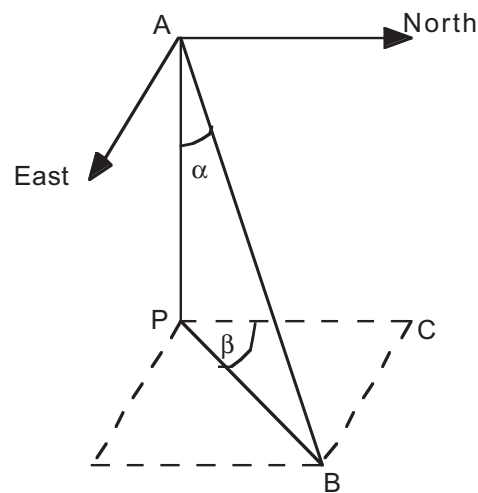

According to the diagram above:

$$\alpha = \frac{\alpha_A + \alpha_B}{2} = \text{average drift angle}$$

$$\beta = \frac{\beta_A + \beta_B}{2} = \text{average azimuth angle}$$

$$AB = MDB - MD = \text{course length}$$

$$PB = \text{course displacement} = AB \sin \alpha$$

(i) True Vertical Depth of Station B:

$$PA = \text{true vertical distance} = AB \cos \alpha$$

(ii) North and East Co-ordinate of Station B:

$$PC = \text{North Displacement } (\Delta N) = PB \cos \beta$$

$$CB = \text{East Displacement } (\Delta E) = PB \sin \beta$$

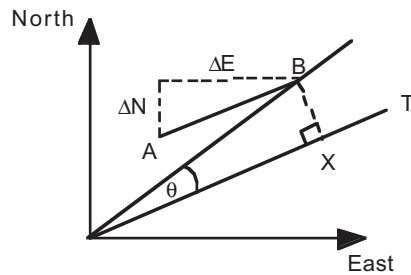

From the plan view of the above:

$$N_B = N_A + \Delta N$$

$$E_B = E_A + \Delta E$$

(iii) Vertical Section of Station B:

From the plan view of the above:

$$\text{Vertical section (VS)} = OX = OB \cos \theta$$

$$\text{closure } OB = \sqrt{E_B^2 + N_B^2}$$

$$\theta = \text{Angle TON} - \text{Angle BON} \quad (\text{target bearing} - \text{bearing of B})$$

$$\tan (\text{Angle BON}) = \frac{E_B}{N_B}$$

(iv) Dogleg Severity (DLS):

$$\text{Dog leg severity} = \cos^{-1}(\cos \alpha_A \cos \alpha_B + \sin \alpha_A \sin \alpha_B \cos (\beta_A - \beta_B))$$

EXERCISE 1 Calculating the Position of a Survey Station

Whilst drilling a deviated well, the Measured Depth, Inclination and Azimuth of the well are measured at station 23 (See survey data below). Calculate the:

North and East co-ordinates,
TVD
vertical section and
dogleg severity

of the next station according to the average angle method

The target bearing is 095° .

STATION	MD	INC.	AZI.	N	E	TVD	VS
22	3135	24.5	92	-30.78	344.60	3086.95	345.02
23	3500	25.5	92.5				

Solutions to Exercise

Exercise 1 Calculating the Position of a Survey Station

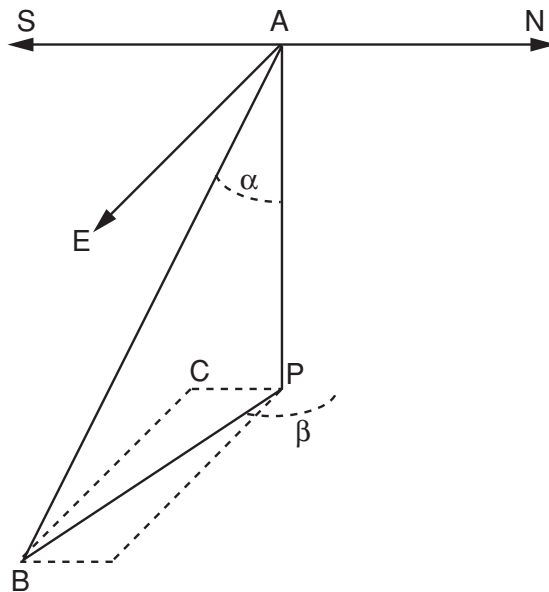

(i) Average Angles:

$$\alpha = \frac{24.5 + 25.5}{2}$$

$$\alpha = 25^{\circ} \quad (\text{Average Drift Angle})$$

$$\beta = \frac{92 + 92.5}{2}$$

$$\beta = 92.25^{\circ} \quad (\text{Average Azimuth Angle})$$

(ii) Course displacement (Station 22 to 23):

$$AB = MDB - MDA = \text{course length}$$

$$\text{Course displacement (PB)} = AB \sin \alpha$$

$$PB = 365 \sin 25^{\circ}$$

$$= 154 \text{ ft}$$

(iii) True Vertical Depth Station 23:

$$\text{TVD Station 23} = \text{TVD Station 22} + \text{True vertical distance (PA)}$$

$$\text{True vertical distance (PA)} = AB \cos \alpha$$

$$PA = 365 \cos 25^\circ$$

$$= 330.80 \text{ ft}$$

$$\text{TVD Station 23} = 3086.95 + 330.80$$

$$= 3417.75 \text{ ft}$$

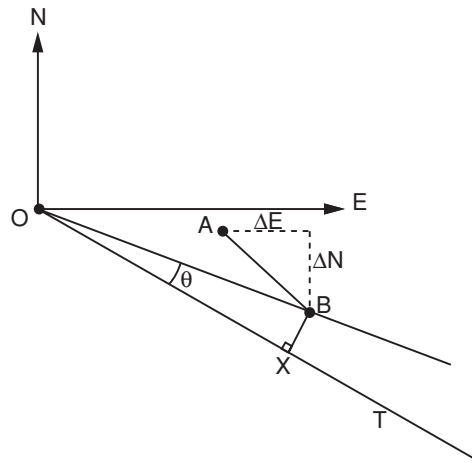

(iv) Northerly Position Station 23

(Note that the well trajectory is in a southerly direction and that the calculations must take account of this):

From the plan view above:

$$N_B = N_A + \Delta N$$

$$\text{Northerly Position Station 23} = \text{Station 22 (N)} - \text{PC}$$

$$\text{PC} = \text{Northing Displacement} = \text{PB} \sin 2.25$$

$$\text{PC} = 154 \sin 2.25$$

$$= 6.05 \text{ ft}$$

$$\text{Northerly Position Station 23} = -30.78 - 6.05$$

$$= -36.83 \text{ ft}$$



(v) Easterly Position Station 23

From the plan view above:

$$E_B = E_A + \Delta E$$

Easterly Position Station 23 = Station 22 (E) + CB

$$\begin{aligned} \text{CB} &= \text{Easting Displacement} = \text{PB} \cos (\beta - 90) \\ &= 153.9 \text{ ft} \end{aligned}$$

$$\begin{aligned} \text{Easterly Position Station 23} &= 344.60 + 153.9 \\ &= 495.8 \text{ ft} \end{aligned}$$

(v) Vertical Section:

From the plan view of the above:

$$\text{Vertical section (VS)} = \text{OX} = \text{OB} \cos \theta$$

$$\text{closure } OB = \sqrt{E_B^2 + N_B^2}$$

$$\begin{aligned} \text{Closure} &= \sqrt{36.83^2 + 495.8^2} \\ &= 497.19 \text{ ft} \end{aligned}$$

$$\text{Angle } \theta = \text{Angle TOE} - \text{Angle BOE} \quad (\text{target bearing} - \text{bearing of B})$$

$$\begin{aligned} \tan (\text{Angle BOE}) &= \frac{\text{Northing B}}{\text{Easting B}} \\ &= \frac{36.83}{495.8} \end{aligned}$$

$$\tan \text{BOE} = 0.0743$$

$$\text{Angle BOE} = 4.25^\circ$$

$$\begin{aligned} \theta &= \text{Angle TOE} - \text{Angle BOE} \quad (\text{target bearing} - \text{bearing of B}) \\ &= 95 - 94.25 \\ &= 0.75^\circ \end{aligned}$$

$$\begin{aligned} \text{Vertical section(VS)} &= \text{OX} = \text{OB} \cos \theta \\ &= 497.19 \cos 0.75 \\ &= 497.15 \end{aligned}$$

(vii) Dog leg severity (DLS):

$$\begin{aligned} \text{Dog leg severity (DLS)} &= \cos^{-1}(\cos\alpha_A \cos\alpha_B + \sin\alpha_A \sin\alpha_B \cos(\beta_A - \beta_B)) \\ &= \cos^{-1}(\cos 24.5 \cos 25.5 + \sin 24.5 \sin 25.5 \cos(92 - 92.5)) \\ &= \cos^{-1}(0.9998) \end{aligned}$$

$$\text{DLS} = 1.15$$

Since this DLS is measured over 365 ft it can be expressed as:

$$= \frac{1.15}{365} \times 100 = 0.31^0 \text{ per 100ft}$$

STATION	MD	INC.	AZI.	N	E	TVD	VS
22	3135	24.5	92	-30.78	344.60	3086.95	345.02
23	3500	25.5	92.5	-36.83	495.8	3417.75	497.15

Measurement While Drilling **B**

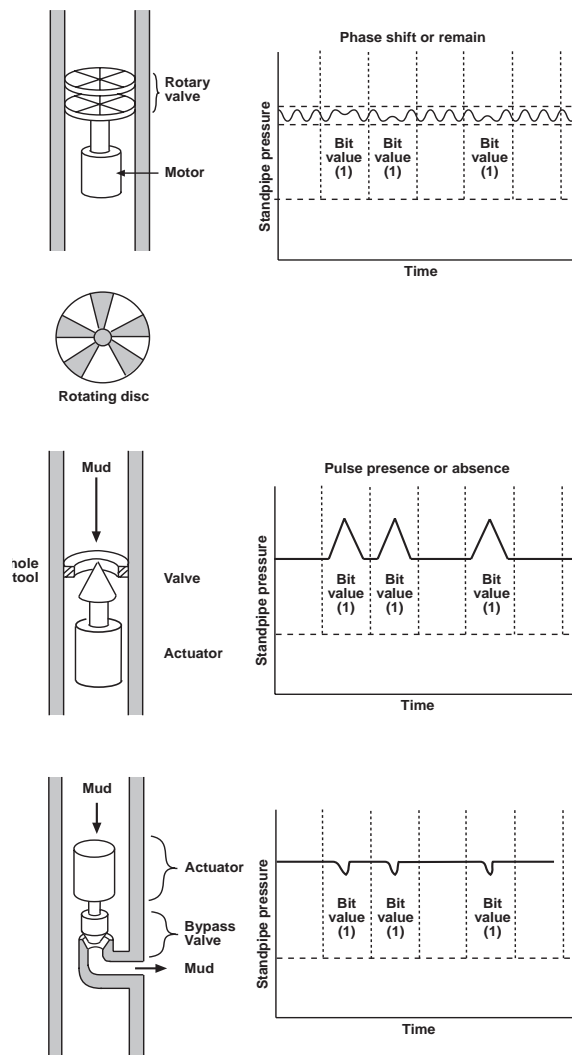

CONTENTS

1. INTRODUCTION
2. MWD SYSTEMS
 - 2.1 Power Sources
3. MWD - DIRECTIONAL TOOLS
 - 3.1 Calculations for Inclination, Toolface and Azimuth
 - 3.2 Normal Surveying Routine
 - 3.3. Accuracy of MWD Surveys
4. MWD - GAMMA RAY TOOLS
5. TRANSMISSION AND CONTROL SYSTEMS
6. SURFACE SYSTEM
7. EXAMPLE SYSTEMS





LEARNING OBJECTIVES

Having worked through this chapter the student will be able to:

General:

- Describe the benefits of using and the general principles behind the MWD concept.
- describe the applications of MWD tools.

MWD Systems:

- Describe the component parts of an MWD system.
- Describe the three mud pulse telemetry techniques.
- Describe the advantages and disadvantages of the various types of Power systems.
- Describe the directional surveying equipment used in MWD tools.
- Describe the Petrophysical and drilling sensors used in MWD tools.

Calculation of Inclination, toolface and azimuth:

- Calculate the inclination, toolface and azimuth using data from accelerometers and magnetometers.

Surveying Routine:

- Describe the operations involved in conducting a survey using an MWD system.

Transmission and Control Systems:

- Describe the transmission and control systems used in MWD tools.

Surface System:

- Describe the surface systems used in MWD systems.

1. INTRODUCTION

Measurement While Drilling - MWD systems allow the driller to gather and transmit information from the bottom of the hole back to the surface without interrupting normal drilling operations. This *information* can include directional deviation data, data related to the petrophysical properties of the formations and drilling data, such as WOB and torque. The information is gathered and transmitted to surface by the relevant sensors and transmission equipment which is housed in a non-magnetic drill collar in the bottom hole assembly (Figure 1). This tool is known as a **Measurement While Drilling Tool - MWD Tool**. The data is transmitted through the mud column in the drillstring, to surface. At surface the signal is decoded and presented to the driller in an appropriate format. The transmission system is known as **mud pulse telemetry** and does not involve any wireline operations.

Commercial MWD systems were first introduced in the North Sea in 1978 as a more cost effective method of taking directional surveys. To take a directional survey using conventional wireline methods may take 1-2 hours. Using an MWD system a survey takes less than 4 minutes. Although MWD operations are more expensive than wireline surveying an operating company can save valuable rig time, which is usually more significant in terms of cost.

More recently MWD companies have developed more complicated tools which will provide not only directional information and drilling parameters (e.g. torque, WOB) but also geological data (e.g. gamma ray, resistivity logs). The latter tools are generally referred to as Logging While Drilling - LWD Tools. As more sensors are added the transmission system must be improved and so MWD tools are becoming more sophisticated. Great improvements have been made over the past few years and MWD tools are now becoming a standard tool for drilling operations.

2. MWD SYSTEMS

All MWD systems have certain basic similarities (Figure 1)

- **a downhole system** which consists of a power source, sensors, transmitter and control system.
- **a telemetry channel** (mud column) through which pulses are sent to surface.
- **a surface system** which detects pulses, decodes the signal and presents results (numerical display, geological log, etc.).

The main difference between the 3 MWD systems currently available is the method by which the information is transmitted to surface. All three systems encode the data to be transmitted into a binary code and transmitting this data as a series of pressure pulses up the inside of the drillstring. The process of coding and decoding the data will be described below. The only difference between the systems is the way in which the pressure pulses are generated (Figure 2).

(i) Negative Mud Pulse Telemetry

In all systems fluid must be circulating through the drillstring. In the negative mud pulse system a valve inside the MWD tool opens and allows a small volume of mud to escape from the drill string into the annulus. The opening and closing of this valve creates a small drop in standpipe pressure (50 - 100 psi), which can be detected by a transducer on surface.

(ii) Positive Mud Pulse

In the positive mud pulse system a valve inside the MWD tool partially closes, creating a temporary increase in standpipe pressure.

(iii) Frequency Modulation (Mud siren)

In the frequency modulation system a standing wave is set up in the mud column by a rotating slotted disc. The phase of this continuous wave can be reversed. The data is transmitted as a series of phase shifts.

Many tools also include the ability to record downhole data for later retrieval at surface. Although this undermines the principle of access to 'real time' data it allows the operator to gather large volumes of data (typical petrophysical data) and therefore eliminate expensive electric wireline logging operations.

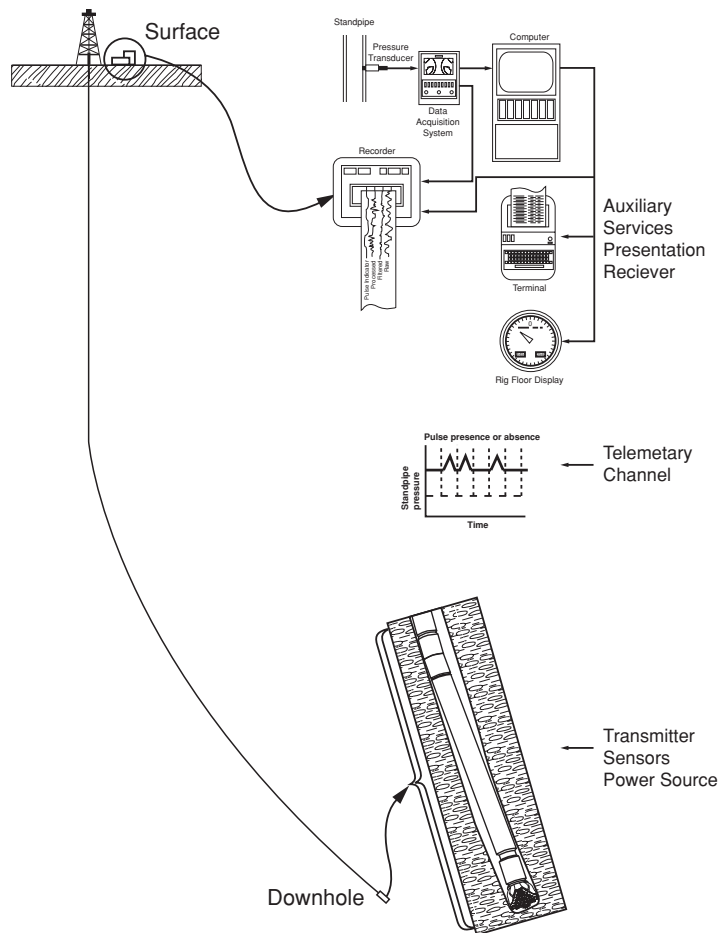

Figure 1 MWD System

Tool Sizes	1 3/4" OD - 9 1/2" OD
Max. Temp.	150°C
Max. Press.	20,000psi
Power Sources	Lithium Batteries(up to 800 hrs op. time) /Turbine
Press. Drop	13-300 psi @ 1000 gpm
Telemetry Type	Positive Pulse/Negative Pulse/ Siren/EM/Downhole Recording
Sensors	Directional (MTF/GTF) Petrophysical (Gamma Ray/Resistivity/Neutron) Drilling (Vibration/DWOB/Torque/Temp./Ann. Press.)

Table 1 MWD Tool Specifications

2.1 Power Sources

Since there is no wireline connection to surface all the power required to operate the MWD tool must be generated downhole. This means that either a battery pack or a turbine-alternator must be installed as part of the MWD tool. The turbine has been the standard method of power generation in the positive pulse and frequency modulation tools. Since less power is required in the negative pulse system batteries have been used. However, with more sensors being added and higher data rates required, batteries are being replaced with turbines in negative pulse systems also.

Turbines have several advantages over batteries (Table 2) but turbines are more prone to mechanical failure. Filter screens are used to prevent debris in the mud from damaging the turbine

Power Source	Advantages	Disadvantages
Batteries (Li)	Compact	Temp. Limit (150° C) Time Limit (100 to 800 hrs)
Turbine	Higher Power Output than Batteries Unlimited Operating Time	Filters Required

Table 2 Advantages and Disadvantages of MWD Power Systems

3. MWD - DIRECTIONAL TOOLS

All MWD systems use basically the same directional sensors for calculating inclination, azimuth and tool face. The sensor package consists of 3 orthogonal accelerometers and 3 orthogonal magnetometers (Figure 3).

An **accelerometer** will measure the component of the earth's gravitational field along the axis in which it is oriented. It works on the "force-balance" principle. A test mass is suspended from a quartz hinge which restricts any movement to along one axis only (Figure 4). As the mass tends to move due to gravity acting along

that axis, its central position is maintained by an opposing electromagnetic force. The larger the gravitational force, the larger the pick-up current required to oppose it. The voltage drop over a resistor in the pick up circuit is measured, and this is directly related to the gravitational component. Depending on the orientation of the BHA the reading on each accelerometer will be different. From these 3 components the angle of inclination and tool face can be calculated (Equations 1 and 2).

A **magnetometer** will measure the component of the earth's magnetic field along 1 axis. If a wire is wrapped around a soft iron core (Figure 5) and then placed in a magnetic field, the current induced in the pick-up circuit will vary depending on the angle at which the toroid is placed. Therefore the size of current is related to the direction of the coil with respect to the direction of magnetic field. As with the accelerometer the voltage is measured across a resistor in the pick-up circuit of the magnetometer. The voltages read at each magnetometer can then be used to calculate azimuth (Equation 3).

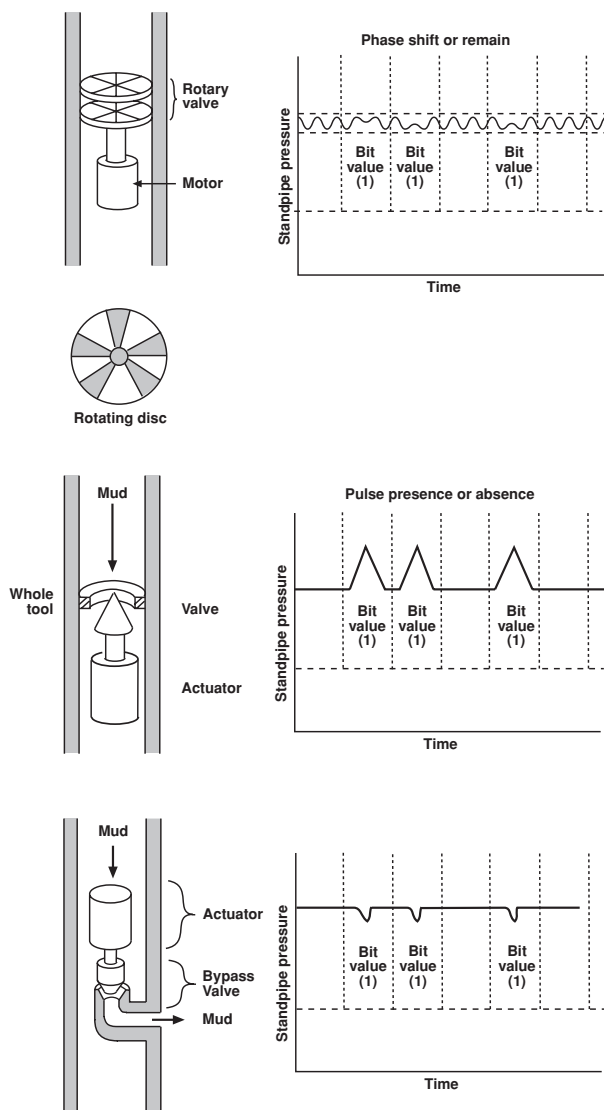

Figure 2 Mud Pulse Telemetry Systems

3.1 Calculations for Inclination, Toolface and Azimuth

In the following equations a, b, c, x, y, z refer to the accelerometer and magnetometer readings with axes as shown in Figure 3.

Inclination (α) - the angle between C accelerometer and vertical. Looking at a vertical cross-section

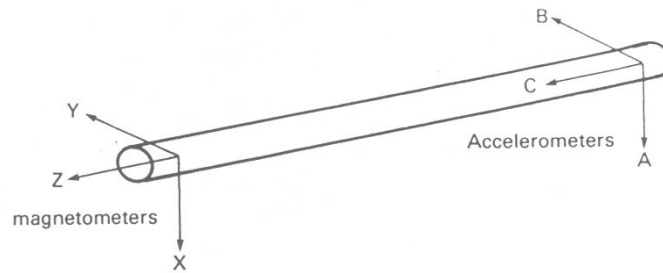

Figure 3 Orientation of Sensors in Tool

$$\alpha = \tan^{-1} \sqrt{\frac{a^2 + b^2}{c}}$$

Equation 1 Inclination of Tool

Toolface (β) - the angle between high side and B accelerometer. Looking down the tool along the C axis:

$$\beta = \tan^{-1} \left(\frac{a}{b} \right)$$

Equation 2 Toolface of Tool

(Note: This gives the toolface of the MWD tool itself. To measure the toolface of the bent sub the offset angle must be included).

Azimuth (θ) - the angle between the Z axis and magnetic North, when projected on to the horizontal plane. Looking in the horizontal plane we define 2 vectors V_1 and V_2 where V_1 lies along tool axis.

$$V_1 = z \sin \alpha + x \cos \alpha \sin \beta + y \cos \beta \cos \alpha$$

$$V_2 = x \cos \beta - y \sin \beta$$

$$\theta = \tan^{-1} \left(\frac{V_2}{V_1} \right)$$

and substituting for a , b

$$\theta = \tan^{-1} \left[\frac{c(xb + yb) + z(a^2 - b^2)}{g(xb - ya)} \right]$$

Equation 3 Azimuth of Tool

(Note: this gives Magnetic azimuth, not True azimuth)

Notice that accelerometer readings are also used in the calculation of azimuth. If there is any mistake in the accelerometer readings, therefore, inclination, toolface and azimuth will all be wrong. Since we are relying on the magnetometers responding only to the earth’s magnetic field any local magnetic effects from the drillstring must be isolated. There must be enough non-magnetic drill collars above and below the sensors to stop any such interference. As a result of this the sensors will be operating 40' - 80' behind the bit (the exact distance must be known before the tool is run).

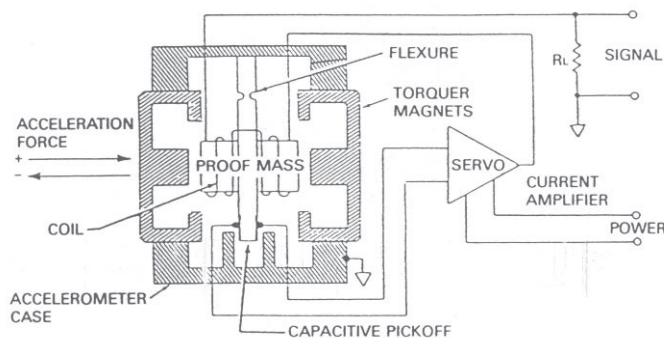

Figure 4 Accelerometer

3.2 Normal Surveying Routine

The usual practice in taking a survey is to drill to kelly down and make the connection. Run in the hole and tag bottom. Pick up 5'-10' and keep pipe steady for 2 minutes (this allows survey data to be stored). Re-start drilling and survey data is transmitted to surface. In some tools the transmission is initiated by rotation, in others it senses pump pressure. During a steering run where a mud motor is being used an update of toolface is usually transmitted every minute. This is of great value to the directional driller as he monitors the progress of the well.

3.3. Accuracy of MWD Surveys

MWD companies quote slightly different figures for accuracy but generally within the following limits:

<u>Inclination</u>	<u>Azimuth</u>	<u>Toolface</u>
+/- 0.25°	+/- 1.50°	+/- 3.00°

These figures compare favourably with single shot accuracies and MWD offers the advantage of being able to repeat surveys at the same depth with little loss in rig time

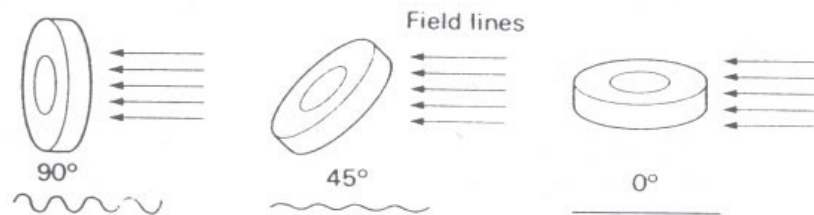

Figure 5 Magnetometer

4. MWD - GAMMA RAY TOOLS

The GR log is a long established part of formation evaluation. Gamma rays in the formation are emitted mainly by radioactive isotopes of Potassium, Thorium and Uranium. These elements occur primarily in shales, and so the GR log is a good shale indicator.

Apart from the obvious geological applications the GR log from an MWD system has important engineering applications (Table 3). There has been a big increase in the use of GR logs run in combination with the MWD directional tooltool

Generic Application	Specific Application
Geological	Immediate indication of change in Lithology Picking Formation Tops, Coring Points Shaliness (Vclay) indicator Differentiate between cuttings and cavings Correlation with other wells
Engineering	Selecting Casing Points Identifying troublesome formations Identifying drilling problems Running checklog prior to EWL

Table 3 MWD Application

Since any change in lithology must be known as quickly as possible the GR sensor should be placed as near the bit as possible, below the directional sensors. Running an MWD GR log has the added problems of rigging up a depthtracking system.

The type of sensors used to detect gamma rays must be both robust and efficient. The most robust sensor is the Geiger-Muller tube, but unfortunately it will only detect a small percentage of the rays being emitted by the formation. A more sensitive but less rugged sensor, is the Scintillation counter. Both types are used in MWD GR tools but the scintillation counter is the more popular.

It is interesting to compare GR and Resistivity logs from an MWD tool with those obtained from wireline logging after the well has been drilled (Figure 6). Several points must be borne in mind when making these comparisons:

- (i) The logging speeds are very different (wireline @ 1800 ft/h MWD @ 10 -100 ft/h). The resolution of the two logs will therefore be affected.

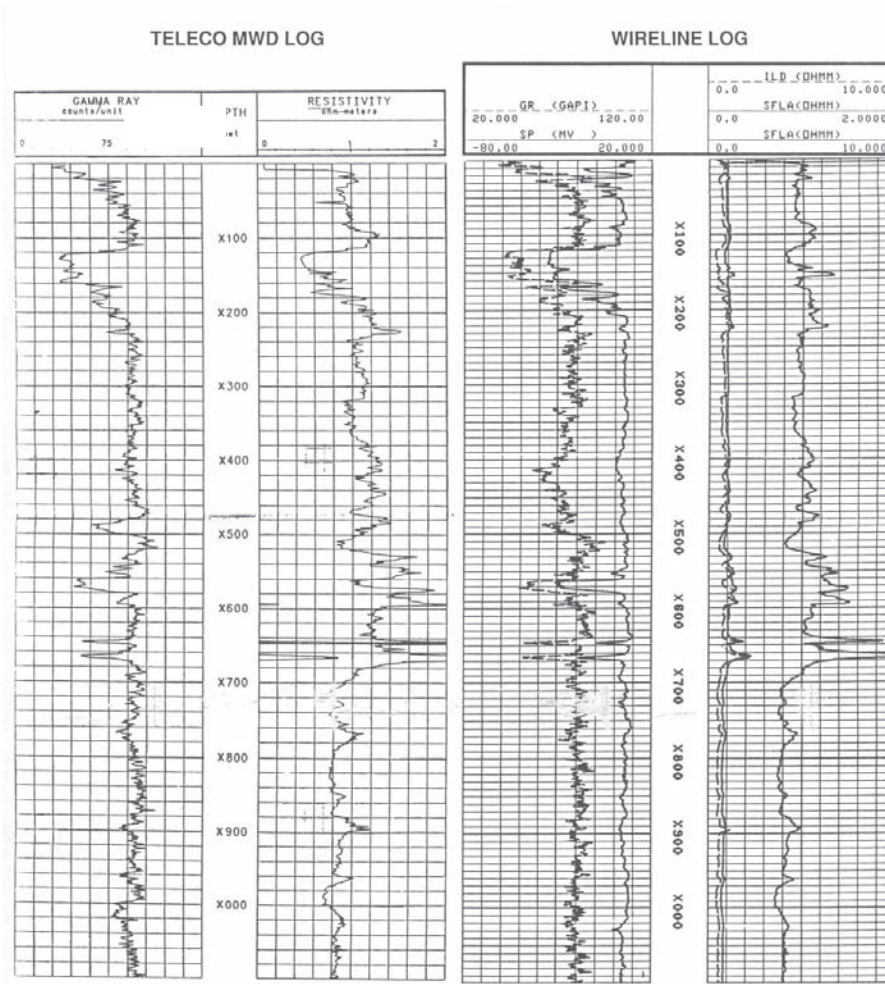

Figure 6 Comparison of MWD and Wireline Log

- (ii) Wellbore conditions may be different since the MWD log was made, e.g. cavings.

- (iii) MWD log is made through a drill collar, so the attenuation of gamma rays will be greater.
- (iv) Central position of the sensors may be different, especially in high angled holes.

Directional sensors and GR sensors are well established for MWD use. More sensors are being developed and the term LWD - Logging Whilst Drilling is now used to describe these tools.

5. TRANSMISSION AND CONTROL SYSTEMS

There is a wide variation in the design of these electronic packages, and they are being continually upgraded. The voltages at each sensor must be read and stored in the memory until the tool is ready to transmit. The control system must co-ordinate the acquisition, storage and transmission of this data. Since there is no electrical on/off switch controlling the system from the surface the tool must react to some physical change (e.g. detecting an increase in pump pressure). Once transmission is initiated the data is sent to surface via the mud column as a series of pulses.

In some systems it is the presence or absence of a pulse which carries the information, in others it is the time interval between pulses. Although these pulses travel at around 4000 ft/sec several pulses may be necessary to transmit one number. With more sensors and more data to transmit the control system becomes a critical factor (e.g. valuable GR signals may be lost while the tool is sending directional data). There is also the problem of collecting vast amounts of data, but not being able to transmit quickly enough. Transmission speeds of up to 0.8 bits per second are available. Survey data words typically consist of 10 bits, and formation data words consist of 11 bits.

Variable	Update Time (sec.)	
	@ 3bps	@ 6bps
Gravity Toolface	10.8	5.4
Phase Shift Resistivity	28.9	14.4
Attenuation Resistivity	28.9	14.4
Gamma Ray	28.9	14.4
Downhole WOB	43.3	21.7
Downhole Torque	43.3	21.7
Continuous Direction	86.7	43.3
Continuous Inclination	86.7	43.3
Shocks/sec.	86.7	43.3

Table 4 MWD Data Update Rates

6. SURFACE SYSTEM

All MWD systems have a pressure transducer connected to the standpipe manifold. This transducer must be sensitive enough to detect small pressure changes (50-100 psi) occurring for only \pm/\leq sec. The series of pulses must then be decoded and processed to give the required information.

The simplest surface system is that used by Teleco (positive pulse). This has a microprocessor included in the downhole tool so that only numerical values of azimuth inclination and toolface need be transmitted to surface. A simple binary code is used whereby a pulse detected within a certain time period = 1, no pulse detected = 0. The binary number is then converted to a decimal number for the final result. The equipment necessary to do this can easily be installed in the driller's dog house. In other systems only the raw data is sent to surface, in which case more sophisticated equipment is needed (electronic filters, computers, etc.). This equipment is usually housed in a special cabin or in the mudlogging unit. Since this cabin may be located some distance away, the survey results are relayed to a rig floor display unit where the directional driller can see them (Figure 7). Formation evaluation logs require plotting facilities which are also housed in the cabin.

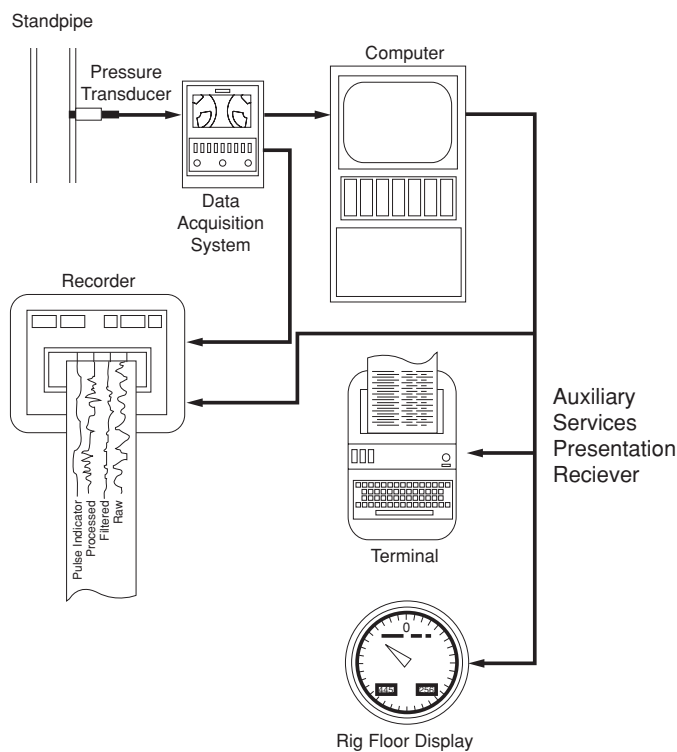

Figure 7 Surface Processing and Reporting System

7. EXAMPLE SYSTEMS

A typical Resistivity-Gamma-Directional MWD Tool is shown in Figure 8. The specifications of this tool configuration are also presented.

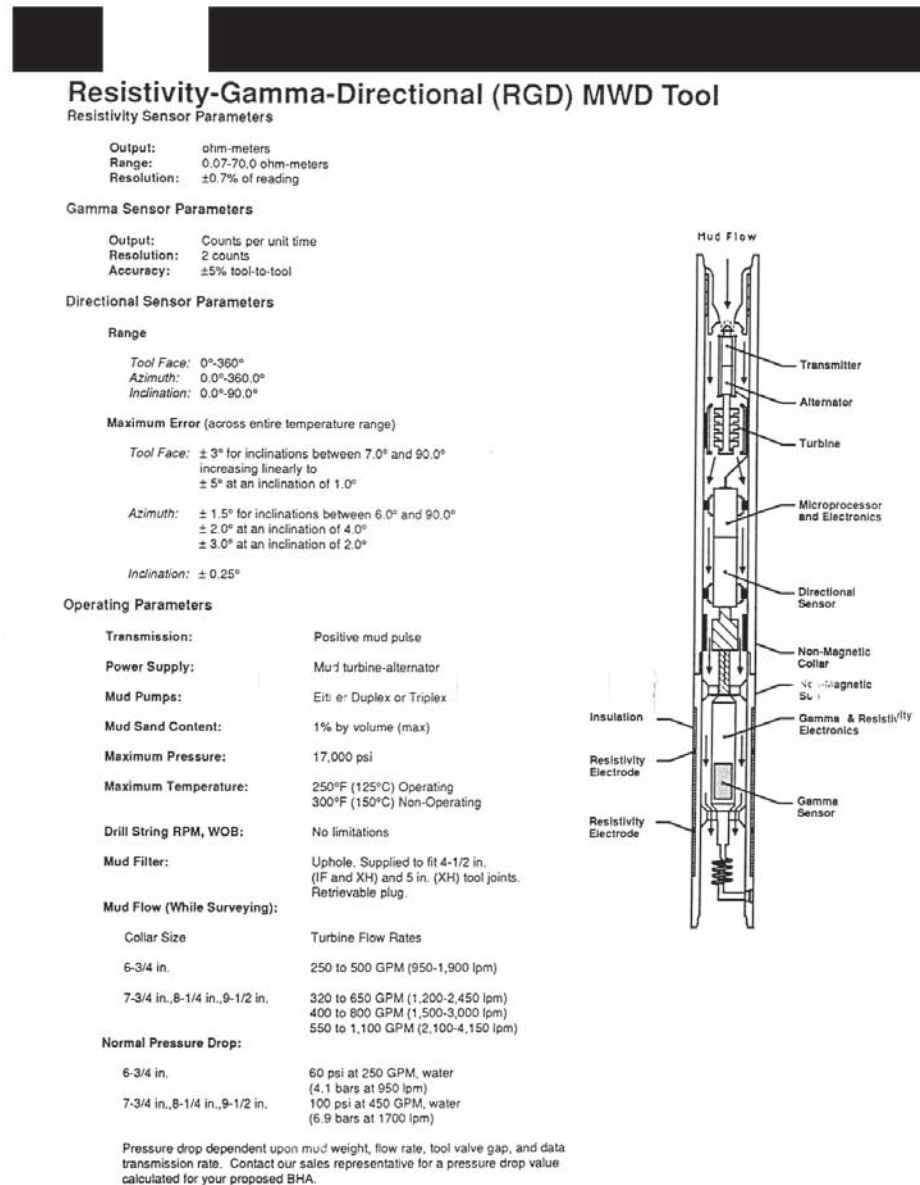
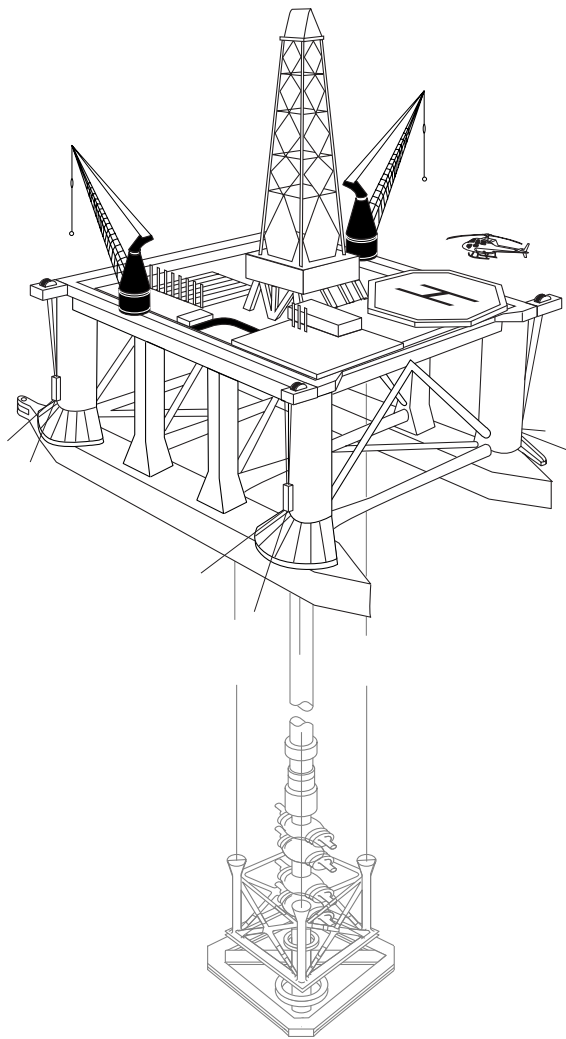

Figure 8 Typical MWD Tool Configuration

Subsea Drilling **14**



CONTENTS

INTRODUCTION

1. DRILLING THE WELL

- 1.1 Positioning the Rig
- 1.2 Running the Temporary guide base (TGB)
- 1.3 Drilling the 36" Hole
- 1.4 Running and Cementing the 30" Casing
- 1.5 Installation of the Diverter
- 1.6 Drilling the 26" Hole
- 1.7 Running and Cementing the 18 5/8" Casing
- 1.8 Installing the BOP
- 1.9 Drilling the 17 1/2" Hole
- 1.10 Running and Cementing the 13 3/8" Casing
- 1.11 Drilling the 12 1/4" Hole
- 1.12 Preparing the well for completion

2. COMPLETING THE WELL

- 2.1 Installing the tubing string and tubing hanger
- 2.2 Removal of the BOP Stack and Installation of the Xmas Tree.
- 2.3 Cleaning up the well

3 SUSPENDING THE WELL

4. ABANDONMENT





LEARNING OBJECTIVES

Having worked through this chapter the student will be able to:

Procedure for drilling a subsea well:

- Describe the subsea BOP and riser equipment used to drill from a floating drilling vessel
- Describe the guide base and wellhead equipment used to drill a subsea well from a floating vessel
- Describe the steps involved in the process of drilling a subsea well.

INTRODUCTION

The operations and equipment used to drill a well from a production platform are almost identical to those used for a land well. A conductor is driven into the seabed and the hole sections are drilled through wellhead and BOP equipment which is similar to that used on land locations. The wellhead and BOP are located on the lower deck of the platform. When the well has been drilled and completed the Xmas tree (which is also similar to that used on land locations) is mounted on top of the wellhead.

The type of wellhead and blowout prevention equipment used when drilling a well from a mobile drilling rig will be quite different from that used on a platform based operation. The equipment used in this case will depend on whether the operation is being conducted from a floating drilling vessel (drillship or Semi-submersible) or from a stable, Jackup drilling vessel. The vessel used will in turn depend largely on whether the well is an exploration or development well and the water depth in which it is being drilled.

When drilling from a Jackup, the drilling operations are very similar to platform-based or land-based operations with a conductor being driven into the seabed and conventional wellhead and surface BOP stack equipment being used. However, since the Jackup will have to move off location when the drilling operation is complete the casing strings must be physically supported at the seabed and it must be possible to remotely disconnect the casing strings between the seabed and surface when the operation is complete. The only alternative to this seabed support is to leave a 'free-standing' conductor on location but in most areas this is not a feasible alternative. Seabed support for such wells is provided by a Mudline suspension (MLS) system. The MLS system is a series of full bore housings and hangers run with the casing strings and is discussed fully, later in this chapter.

When drilling with an MLS system the casing strings are temporarily extended back from the mudline to surface and the conventional wellhead and BOP stack is nipped up on top of these extension strings (just beneath the rigfloor). The MLS system only provides physical support for the casing strings. All annulus sealing and monitoring functions are provided by the wellhead at surface.

When the well has been drilled it is possible to convert the MLS system into a subsea wellhead, such that the well can be completed subsea, although this is not a typical application of MLS technology. These systems are generally used on development drilling operations, where a platform is to be used for production purposes. The operation is conducted as follows: a Jackup drilling unit and MLS system is used to drill the wells; the wells are suspended and the tieback strings removed; and the rig is moved away from the location. When the platform is complete it is installed over the location and the wells are re-entered and re-connected, with extension strings, to the lower deck of the platform and a conventional wellhead and Xmas tree system is installed on top of the extension (tie-back) strings. This is known as a 'pre-drilling' operation.

When drilling from a floating vessel drillship or Semi-submersible (Figure 1) there is always the possibility that, at some point during the drilling operation, the vessel will have to disconnect from the well or even move off location due to bad weather. The wellhead and all other BOP equipment are therefore situated on the seabed with the drilling fluids being circulated back to the drilling vessel via a marine riser. The BOP stack on the seabed is the primary well control device, in the event of a kick. A hydraulic latch between the marine riser and the BOP stack ensures that it is possible to close in the well, disconnect the marine riser from the top of the BOP stack and move the rig off location safely at any stage during the drilling operation. When the well has been drilled and the well is either suspended for later completion or it may be completed immediately and a subsea Xmas tree installed on the wellhead. We will assume that the well is to be completed immediately after the drilling operations are complete.

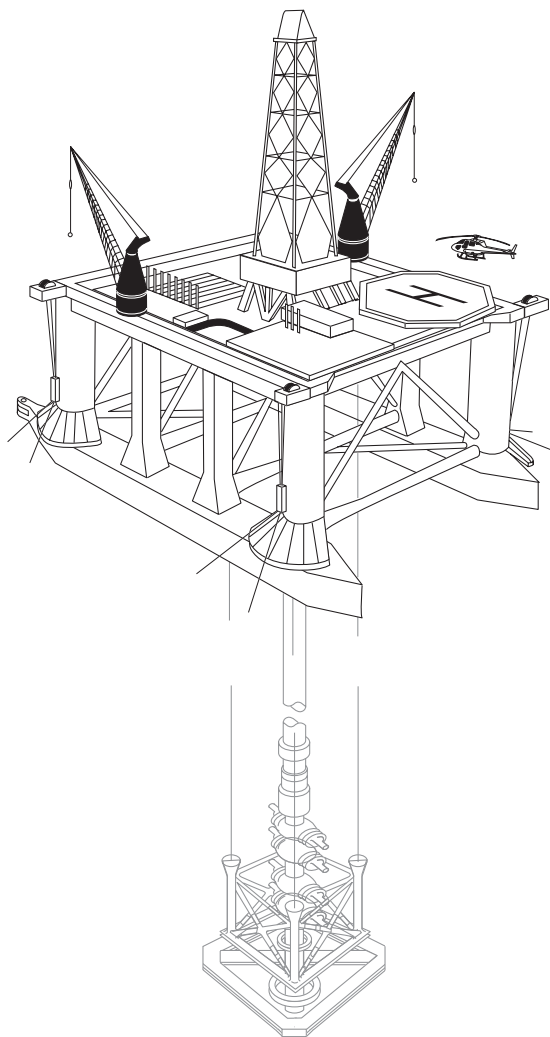

Figure 1 Semi-Submersible Drilling Rig

The first part of this chapter will outline the operations and equipment used when drilling and completing a well from a floating vessel, using a subsea wellhead

system. A description of the operations involved in drilling from a Jackup, using an MLS system is given in the next chapter. For continuity purposes, the casing scheme used as the basis for discussion in this chapter will be : 30", 18 5/8", 13 3/8", 9 5/8" and 7" (Figure 2). It is worth noting that all manufacturers use the same basic principles, although there are certain differences in the design and operation of some components.

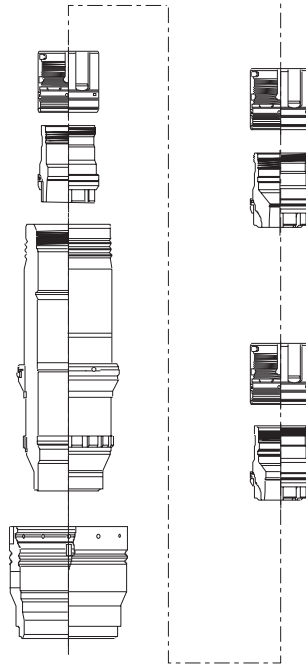

Figure 2 Casing Configuration

There are two types of guidance system which can be used to run subsea wellhead equipment to the seabed when drilling from a Drillship or Semi-Submersible - a guideline and guidelineless system. The choice of system will depend on water depth. In water depths of less than 1500 ft this equipment is run and retrieved using wire rope guidelines anchored at the seabed. In the case of very deep water (>1500ft) it is necessary to use techniques which allow the equipment to be run and retrieved remotely without the use of divers or fixed guidelines (guidelineless system). The more common guideline system will be described in this chapter. The description relates to those operations performed when using a VETCO wellhead system.

1. DRILLING THE WELL

1.1 Positioning the Rig

The drilling location is generally indicated by a survey vessel, using a marker buoy, prior to the arrival of the drilling vessel. The rig is towed onto the location and anchor-handling tugs are used to drop the anchors in a pre-scribed pattern. The anchors are tensioned to ensure that they are securely set into the seabed,

then slacked off and adjusted to obtain the final position and heading of the rig. This whole operation may take a few hours or a few days, depending on weather conditions. The drilling rig may be held in position over the well by using anchors or by using dynamic positioning techniques. If anchors are used, great care must be taken to ensure that the anchors do not damage seabed pipelines.

The condition of the seabed directly beneath the rig will generally have been checked by a seabed survey before the rig arrived on location, but a final check is generally made with an ROV prior to running the equipment.

1.2 Running the Temporary Guide Base (TGB)

The first stage in the drilling operation is to establish an anchor point, on the seabed, for the 4 guidelines ($\frac{3}{4}$ " or $\frac{7}{8}$ " diameter wire) which are used to guide drilling tools and casing from the rig to the seabed. The guidelines are attached to a Temporary Guide Base - TGB which is the first piece of equipment to be lowered to the seabed. The guidelines are attached to the base at a 6ft radius from the centre and are kept in tension.

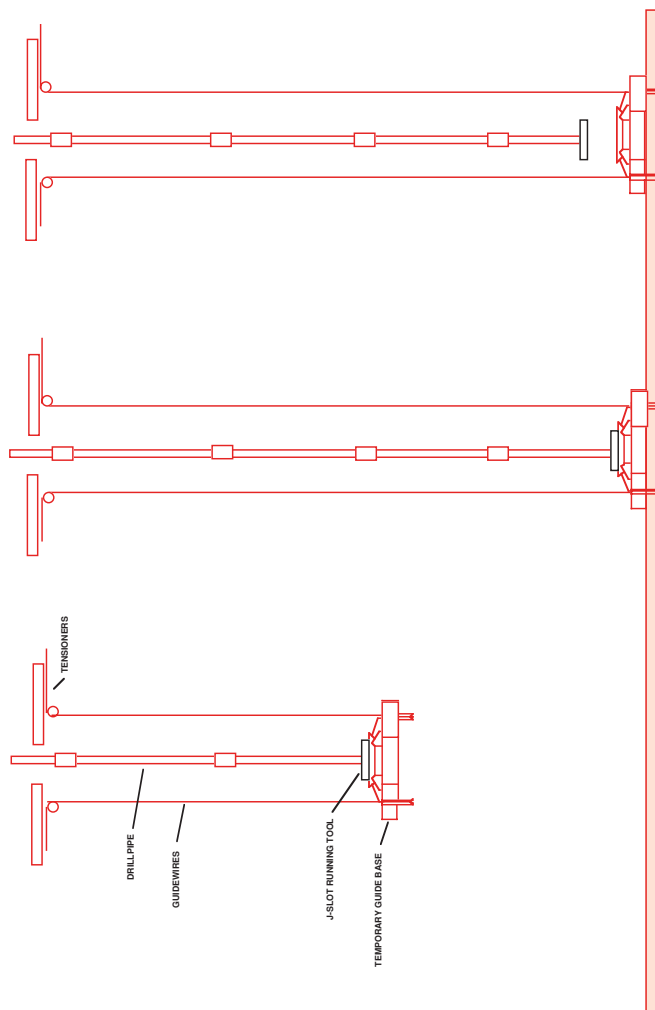

Figure 3 Running the Temporary Guide Base

The TGB is positioned in the moonpool of the rig and a special running tool, run on drillpipe, (Figure 3) is latched into the base. The running tool has 4 pins which engage J-slots on the internal profile of the 46" slot. Sacks of barite or cement are loaded onto the base, to increase its weight to 25000-30000 lbs, and it is lowered to the seabed on drillpipe. When the TGB has landed on the seabed the running tool is unlatched by rotating the drillpipe by 1/8 of a turn to the right. The running tool and drillpipe can then be retrieved. A level indicator (bull's eye) on the TGB indicates whether or not the structure is lying in a horizontal position on the seabed. If the TGB is level the tension on each guideline is then adjusted to about 2000 lbs.

1.3 Drilling the 36" Hole

A 36" hole is drilled to a depth of 100-200ft. below the seabed. The bit is guided down through the TGB by means of a Utility Guide Frame (UGF) fixed around the drillpipe just above the bit and attached to the guide wires (Figure 4). Once the bit has been guided through the TGB and the first 30ft. of hole has been drilled the UGF is pulled back to surface.

The 36" hole may be drilled using an 18 $\frac{1}{2}$ " bit and 36" hole opener, or a pilot hole may be drilled and opened out to 36" diameter on a second run. The hole is drilled with sea water, with the drilled cuttings settling onto the seabed (no riser or BOP is installed at this stage). Having drilled to the required depth the hole is displaced to mud to prevent debris from settling onto the bottom of the hole when running the 30" casing.

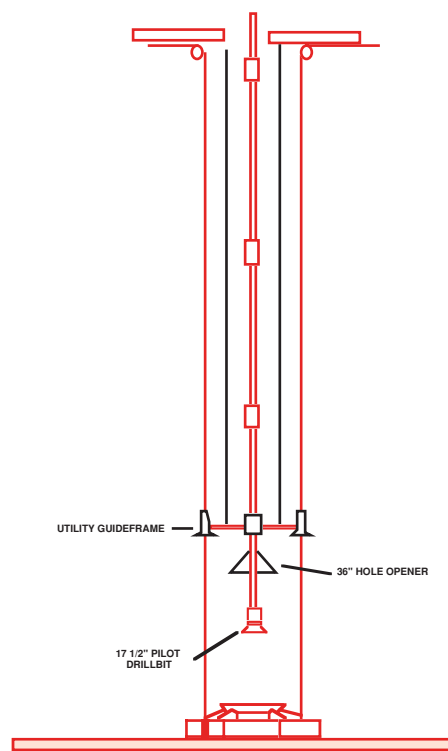

Figure 4 Running the Drillbit to Drill the 36" Hole

1.4 Running and Cementing the 30" Casing

The 30" casing and casing head housing (CHH) is run to the seabed with the Permanent Guide Base - PGB. The PGB provides precise alignment for the BOP stack, and subsequently Xmas tree, over the Wellhead. The four guideposts are 12ft high and spaced at a 6ft radius around the centre of the base. A machined profile on the inside of the central slot provides support for the 30" wellhead housing and allows it to be locked in place. The PGB rests on the TGB.

The PGB is positioned in the moonpool of the rig and the guidelines are inserted into the guide posts. The 30" casing is run from the rig floor through the PGB. The top joint of casing, with the 30" casing head housing welded to it, is lowered through the rotary table, landed on the PGB and locked in place. The 30" Casing Head Housing supports the weight of the 30" casing, locks the 30" casing into the PGB and provides an internal profile onto which the 18 3/4" high pressure wellhead housing will land.

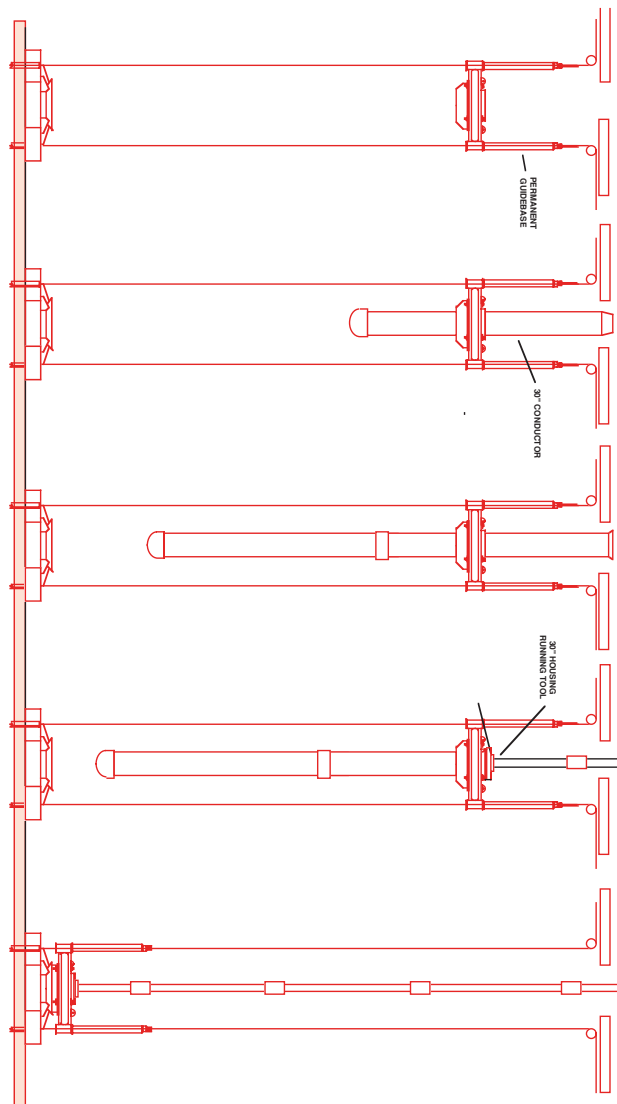

Figure 5 Running the 30" Casing and Permanent Guide Base - PGB

Drill pipe for cementing the casing is run down inside the casing and wellhead and made up to the underside of the 30" running tool. The 30" running tool is made up to the 30" casing housing. The Casing Head Housing running tools can be cam or rotation operated. They have drillpipe thread preparations on their upper and lower end. The upper connection is to allow the tool to be run on drillpipe and the lower is for suspending a cement stinger inside the casing. An O-ring on the outside of the running tools seal against a polished surface on the inside of the CHH preventing circulation up the annulus between the cement stinger and 30" casing.

The 30" running tool is then locked into the 30" casing and the casing string and PGB can be picked up as a single unit and run down until the PGB lands on the TGB (Figure 5). The gimbal on the underside of the PGB rests on the funnel of the TGB to give vertical alignment (checked with a the ROV viewing a bullseye indicator on the PGB). The casing is cemented by circulating down the drill pipe and out through the casing shoe until cement returns are observed, on a TV camera, to be coming up between the TGB and the PGB, and spilling onto the seabed. The volume of cement used is generally 100% in excess of the gauge hole annular volume. The cement is then displaced to just above the shoe, the running tool released from the 30" housing and the tool and drill pipe retrieved. The 30" casing is a major load bearing element in the wellhead system and it is essential that the 30" is cemented all the way up to the seabed. If cement is not observed at the seabed a top-up cementation, via a stinger through the PGB, will generally be performed.

Although many companies do use them as standard it is not always necessary to use a TGB. Indeed in soft conditions the TGB may sink into the seabed or settle unevenly. It is possible to drill the 36" hole and run the 30" casing without the help of a TGB. In this case the guidelines are attached to the guideposts of the PGB. Before cementing the 30" casing however, it is important to check that the slope of the PGB is less than 1° (otherwise the BOP stack may not latch properly).

In the case of a very soft seabed the 30" casing can be "jetted" into position. A jetting bit with a stabiliser on drill pipe is run down inside the 30" casing and suspended from the casing running tool. The jetting bit should be spaced out such that it lies about 2ft. from the open-ended shoe joint. The 30" housing is locked onto the PGB and the running tool made up as before. The whole assembly is then lowered to the seabed. Sea water is pumped through the jetting assembly to wash away the formation (holes in the running tool allow the water to escape from the drill pipe/casing annulus and spill onto the seabed). The casing is lowered slowly, as jetting continues, until the PGB is a few feet from the mudline. The jetting is stopped, the running tool released and the drill pipe is retrieved.

1.5 Installation of the Diverter

The 26" hole will generally be drilled with seawater to 1000-2000 ft. In most cases this hole section is drilled without circulation back to the rig and in this case the drilled cuttings are deposited on the seabed. If however, the drill bit encounters an unexpected gas pocket (shallow gas) there will be no blowout protection in place. For exploration wells therefore, a riser and diverter system is normally installed prior to commencing the 26" hole. The riser and diverter system is comprised of 4 basic pieces of equipment (Figure 6) :

- (i) A hydraulic latch to provide a sealed interface between the 30" casing housing and the riser.
- (ii) A flexible joint to allow some deflection of the riser (about 10°).
- (iii) A marine riser to provide a conduit for returns to the rig.
- (iv) A flow diverter to safely vent off any gas that may be encountered.

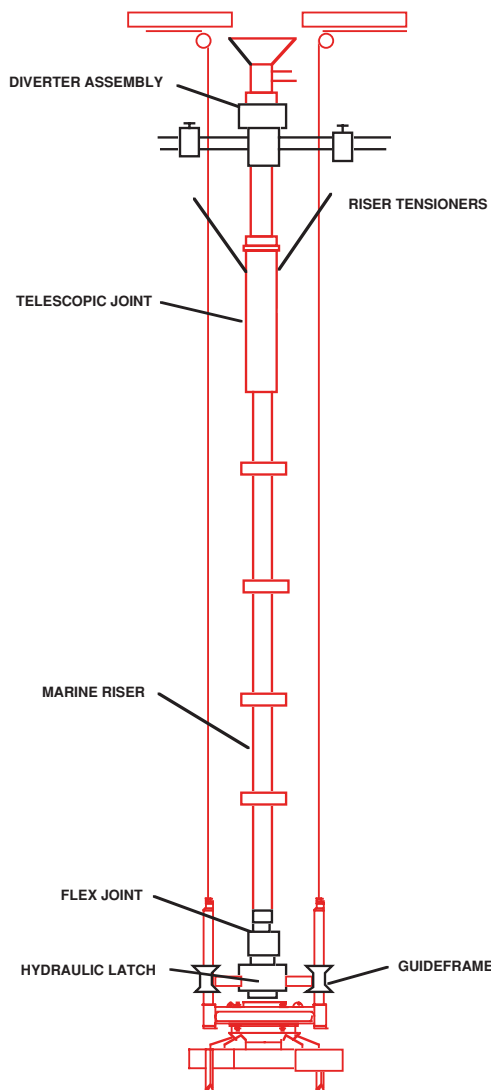

Figure 6 Installing the Diverter

1.6 Drilling the 26" Hole

Due to the I.D. restrictions of the hydraulic latch and riser a 26" bit cannot be run through a diverter system. The 26" hole is therefore drilled by first drilling a small diameter (12 1/4") pilot hole, logging the open formations, removing the diverter assembly and then opening out to 26" diameter. The logging operation is performed to ensure that there are no open hydrocarbon bearing sands in the pilot hole section prior to removal of the diverter assembly. Alternatively the 26" hole is drilled by drilling a small diameter (12 1/4") pilot hole, logging and then running an under-reamer down through the diverter assembly to open the hole out to 26". The diverter assembly will however still have to be removed before running the 18 5/8" casing.

1.7 Running and Cementing the 18 5/8" Casing

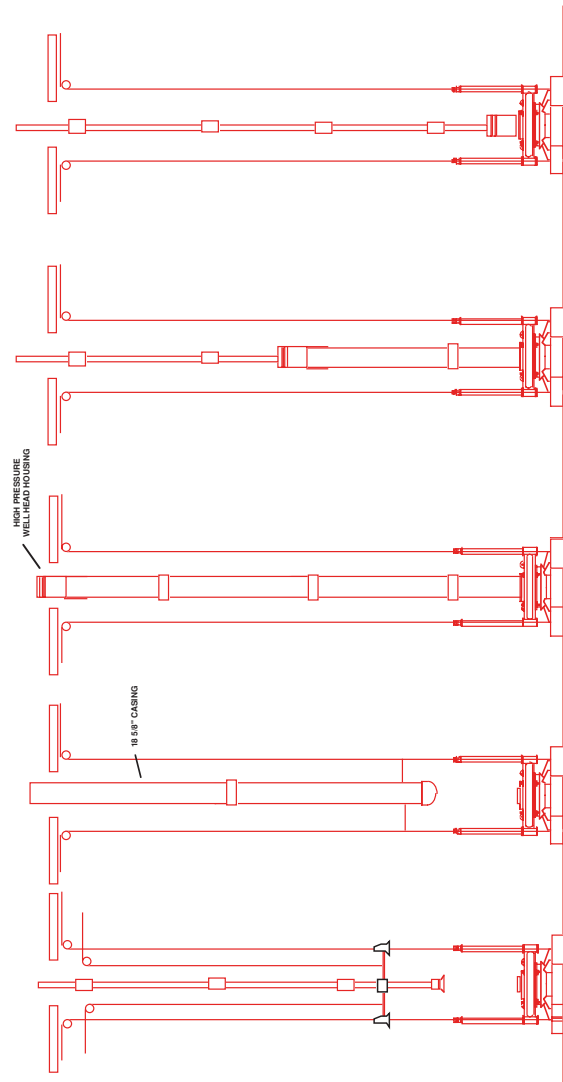

Figure 7 Running the Surface Casing and High Pressure Wellhead Housing - HPWHH

Having drilled the 26" hole the diverter, riser and hydraulic latch are recovered and laid down. The required length of 18⁵/₈" casing string is made up. An 18³/₄" high pressure wellhead housing (with a wear bushing installed) is made up onto the top of the casing. The 18³/₄" Wellhead housing is the high pressure housing onto which the BOP and subsequently Xmas tree will latch and seal. The 13 3/8", 9 5/8" and 7" casing hangers will all land and seal inside this high pressure housing.

As before a drill pipe cementing string, attached to the underside of the running tool, is run down inside the casing. The running tool is then made up (with left hand rotation) into the 18³/₄" housing (Figure 7). The entire assembly is lowered on drill pipe until the 18³/₄" housing lands and locks in place in the 30" housing on the

seabed. The casing annulus is circulated and cemented. The running tool is rotated a few turns to the right for release, and the drill pipe and tool are recovered.

1.8 Installing the BOP

Since the 17¹/₂" hole section will be drilled to considerable depth, a subsea BOP stack and marine riser will generally be required at this stage in the operation. The most common subsea BOP stack configuration used in North Sea operations is the 18³/₄" 10,000 psi single stack system. The BOP stack is comprised of the following components (Figure 8) :

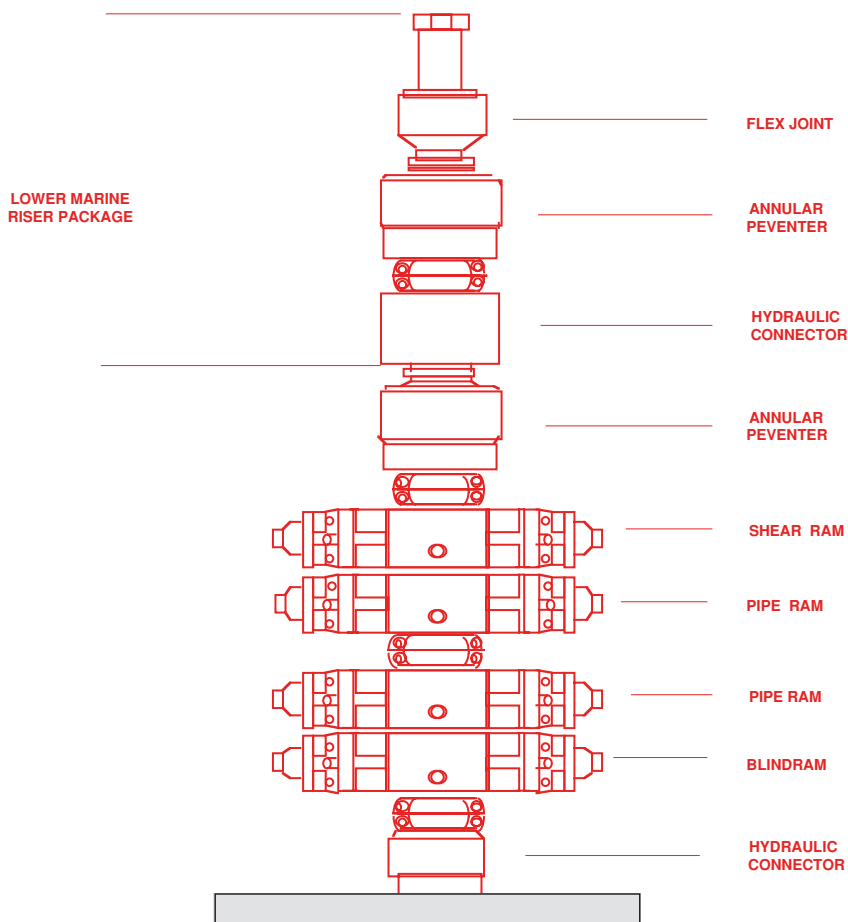

Figure 8 The Subsea BOP

- (i) A hydraulic connector which latches onto and seals on the 18³/₄" wellhead housing.
- (ii) A set of four rams and annular preventer.
- (iii) A “lower marine riser package” (LMRP) comprising of a hydraulic connector which latches onto the top of the BOP stack (allowing the LMRP to be disconnected from the BOP stack and retrieved on the riser if the rig has to move off location for any reason), a second annular preventer and a flexible joint which allows up to 10° of deflection of the marine riser.

- (iv) A marine riser equipped with integral choke and kill lines.
- (v) A telescopic joint at surface to accommodate the heave of the rig whilst the marine riser is maintained in constant tension with a heave compensation device.

The BOP stack, LMRP, riser and choke and kill lines are run in one operation. Once the BOP stack is landed and latched onto the 18 3/4" housing the required tension is set on the marine riser tensioners and the flow line is hooked up. The BOP stack is then pressure tested.

1.9 Drilling the 17 1/2" Hole

The 17 1/2" bit and BHA is run and the 17 1/2" hole section is drilled, taking mud returns to surface. When the casing point has been reached the hole is circulated clean and the drilling assembly recovered in preparation for running the 13 3/8" casing.

1.10 Running and Cementing the 13 3/8" Casing

The wear bushing sitting inside the 18 3/4" housing is removed. The 13 3/8" casing is run into the hole through the BOP stack and riser assembly. The 13 3/8" casing hanger is run together with a seal assembly (or packoff) which is used to seal off the 18 5/8" x 13 3/8" annulus after the cement job is complete. The entire assembly is run in hole on a casing hanger running tool and casing or drillpipe. The system is designed such that the casing can be run, landed, cemented and the seal assembly energised, all in one trip.

Having landed the casing hanger in the 18 3/4" housing the cement is pumped and displaced down the running string. The running string may be either casing joints, extending back to the rig, or drill pipe. In the case of drillpipe a special cement plug retainer is connected to the underside of the casing hanger running tool and the cement operation is conducted in a similar fashion to a liner cementation. At the end of the cement job the running string is rotated to the right. This releases the running tool, while simultaneously energising the packoff assembly on the outside of the hanger. When the packoff is set it can be pressure tested, and then the running tool can be picked up and pulled back to surface. Since the casing is an integral part of the BOP system it is vital that the annulus between successive casings is properly sealed off. It is good practice to flush the wellhead area prior to pulling the running string back to the surface. A wear bushing is installed above the 13 3/8" hanger to protect the sealing surfaces during the next drilling phase.

1.11 Drilling the 12 1/4" Hole

The 12 1/4" bit and BHA is made up and run to just above the cement inside the 13 3/8" casing. Prior to drilling out of the shoe the casing is pressure tested. To ensure that it is safe to drill ahead, a leak-off test is performed immediately after drilling out of the casing shoe. The next section of hole (12 1/4") is drilled to the required depth, cleaned out and the 9 5/8" casing is run and cemented. Exactly the same procedures are used for the 9 5/8" casing, as for the 13 3/8" casing string. If necessary, drilling can continue to greater depths by drilling an 8 1/2" hole and running and cementing 7" casing. The 3 hanger system (13 3/8", 9 5/8", 7") is the most common, but in certain parts of the world 4 hanger systems are necessary (16", 13 3/8", 9 5/8", 7").

1.12 preparing the well for completion

The well is now ready for completion and as stated in the introduction it is assumed that the well is to be completed immediately after the drilling operations are complete. At this stage, there are a number of alternative ways in which the operation may proceed. These routes are dependant on the way in which the well is to be perforated and cleaned up.

The well may be perforated with casing guns prior to the running of the tubing, it may be perforated with tubing conveyed perforating guns run on the tubing, or it may be perforated with through tubing perforators after the well has been completed. The advantages and disadvantages of each of these scenarios are discussed widely in textbooks relating to completion operations and will not be discussed here. It will be assumed that the casing is to be perforated with through tubing guns, after the completion has been installed.

The production casing must be cleaned up and the drilling fluid displaced to brine after the drilling operation is complete and before any production tubing is run in the hole. A casing scraper is run on drillpipe, to the bottom of the production string, and a series of viscous pills, followed by brine, are circulated until the drilling fluid has been completely displaced to clean brine.

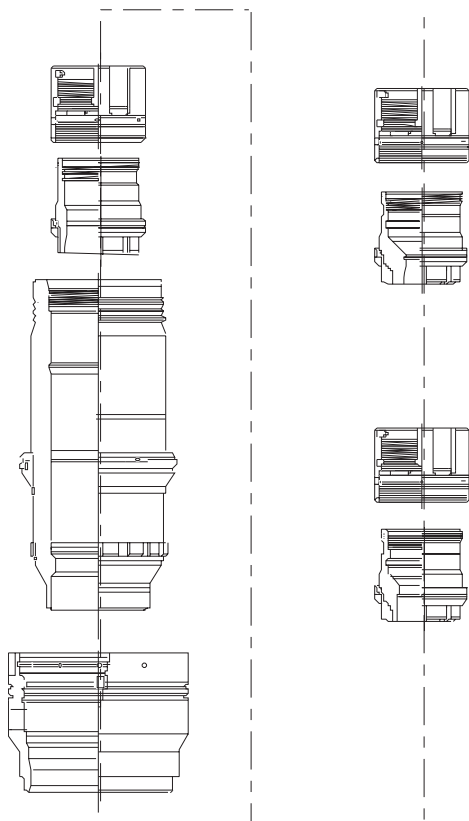

Figure 9 Wellhead Configuration

2. COMPLETING THE WELL

2.1 Installing the tubing string and tubing hanger

The tubing string is made up and run in hole. The tubing hanger is attached to the top of the string and the entire assembly is run through the drilling riser and BOP, on either a completion riser or drillpipe, and landed in the wellhead. If an oriented tubing hanger is used it is oriented with respect to the guideposts, landed, locked in place and the production packer is set. The pressure integrity of the tubing string, tubing hanger to wellhead seals and the production packer are then tested. The operation of the subsurface safety valve is also tested.

Wireline plugs are set in the tailpipe of the packer and the tubing hanger and the completion riser is unlatched from the tubing hanger and retrieved. There are now sufficient barriers to flow to allow the BOP and drilling riser system to be removed safely.

2.2 Removal of the BOP Stack and Installation of the Xmas Tree.

The BOP stack is unlatched from the wellhead and the stack and riser system is retrieved.

The Xmas tree is picked up on a completion riser assembly which consists of:

- (i) A hydraulic connector which latches onto and seals on the tree manifold,
- (ii) A wireline BOP stack which allow the well to be shut in if an emergency situation develops whilst conducting subsequent wireline operations
- (iii) An Emergency disconnect package which latches onto the top of the BOP stack (allowing the EDP to be disconnected from the BOP stack and retrieved on the riser if the rig has to move off location for any reason)
- (iv) A stress joint to accommodate the movement of the riser when working on the well.
- (v) The completion Riser
- (vi) A terminal head to allow surface shutin of the well during flowtesting or workover operations
- (vii) A workover control system

The control system allows the operation of the wellhead and riser connectors, all of the major valves on the tree and the subsurface safety valve. It also provides conduits for testing various seals such as the cavity between the tubing hanger and Xmas tree.

When the tree has been landed the wellhead connector is energised and all of the major functions are tested. The Xmas tree to wellhead seals and riser system are then tested for pressure integrity.



2.3 Cleaning up the Well

The wireline plugs are retrieved from the tubing string. The perforating guns are run and the production casing is perforated. Flow from the well is then initiated and the well is cleaned up and tested. The flow can be initiated in a number of ways. The tubing can be run partially filled, coiled tubing can be used to circulate light fluid or Nitrogen or a circulating device in the tubing string can be opened and the tubing circulated to lightweight fluid prior to perforating.

3. SUSPENDING THE WELL

When the well is cleaned up the master valves on the tree are closed and the riser system is displaced to seawater. The riser is then disconnected from the top of the tree and the riser retrieved. A tree cap is then run and latched onto the top of the tree. The well is now ready for connection of the pipelines and control umbilical and production.

4. ABANDONMENT

If the well is dry and is to be abandoned several cement plugs will be set in the open hole section and at various positions in the casing and the casing will be cut and retrieved as deep as possible. In the North Sea, Health and Safety Executive Regulations require that all strings of casing are cut 10ft. or more below the seabed, and that all structures above this point should be recovered. Also any debris lying on the seabed, within a 70m radius of the drilling location should be removed. Hydraulically operated casing cutting tools can be used to cut through the casing strings from the inside. However, this method is time consuming and will probably cost more than the value of the recovered wellhead. For this reason explosive charges are sometimes used to sever the wellhead below the seabed when the rig has moved off location. This work is usually done by salvage contractors.

Examination and Model Solutions

HERIOT-WATT UNIVERSITY
E d i n b u r g h

8 Pages

Name: _____
 Candidate No.: _____
 Date: _____
 Register No.: _____
 Complete this section but do not
 seal until examination
 is finished

Date: _____

Subject: _____

INSTRUCTIONS TO CANDIDATES

No.	Mk.

- Complete the sections above but do not seal until the examination is finished.
- Insert in box on right the numbers of the questions attempted.
- Start each question on a new page.
- Rough working should be confined to left hand pages.
- This book must be handed in entire with the top corner sealed.
- Additional books must bear the name of the candidate, be sealed and be affixed to the first book by means of a tag provided

PLEASE READ EXAMINATION REGULATIONS ON BACK COVER

target:

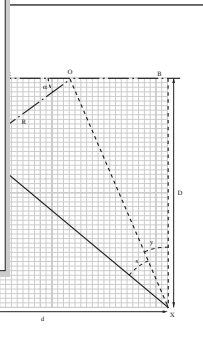

$$\text{Displacement} = \sqrt{3000^2 + 3500^2}$$

$$= 4610 \text{ ft}$$

a. DRIFT ANGLE:

$$\frac{2.5 R}{100} = \frac{360}{2\pi}$$



HERIOT-WATT UNIVERSITY
DEPARTMENT OF PETROLEUM ENGINEERING

Examination for the Degree of
MEng in Petroleum Engineering

Drilling Engineering

Thursday ?? January 200?
09.30 - 12.30

NOTES FOR CANDIDATES

1. This is a Closed Book Examination.
 2. 15 minutes reading time is provided from 09.15 - 09.30.
 3. Examination Papers will be marked anonymously. See separate instructions for completion of Script Book front covers and attachment of loose pages. Do not write your name on any loose pages which are submitted as part of your answer.
 4. This Paper consists of 2 Sections:- A and B.
 5. Section A:- Attempt 5 numbered Questions
Section B:- Attempt 3 numbered Question
 6. Section A:- 40% of marks [8% per Question]
Section B:- 60% of marks [20% per Question]
- Marks for Question parts are indicated in [brackets]
7. This Examination represents 100% of the assessment.
 8. State clearly any assumptions used and intermediate calculations made in numerical questions. No marks can be given for an incorrect answer if the method of calculation is not presented.
 9. Answers must be written in separate, coloured books as follows:-

Section A:- Blue
Section B:- Green

Section A

A1

- (a) List the principle features of a roller cone drillbit and state how the drilling conditions would affect the design of these features. [4]
- (a) What are the criteria used to assess the performance of a drillbit when it has completed its run? Discuss these performance criteria and suggest which you would recommend as the most meaningful? [4]

A2

- (a) Discuss the criteria and considerations which are used to determine the mudweight required for drilling a well. [4]
- (b) Describe how the minimum and maximum mudweight could be quantified. [4]

A3

- (a) List and describe four of the principle indicators that an influx had occurred whilst drilling ahead? Highlight the value of each of these indicators and in particular if there could be any reason for the event, other than an influx, had taken place. [8]

A4

- (a) What are the advantages and disadvantages of oil based mud as opposed to water based mud? [4]
- (b) Describe the way in which two properties of drilling mud are tested? [4]

A5

(a) List and describe the steps involved in drilling a well from a floating drilling vessel. Highlight the aspects of the operation particularly concerned with safety.

[5]

(b) List the major differences between a surface and subsea wellhead system

[3]

A6

(a) List and describe the basic components of an MWD system.

[6]

(b) Describe three applications of an MWD system.

[2]

Section B

B7

- (a) Calculate the burst and collapse loads on the 9 5/8" production casing string detailed in the following data. Select a casing string from those available on the basis of this calculation. State and discuss all assumptions used during the design.

9 5/8" Casing	:	0 - 7900 ft
Top of Packer	:	7200 ft
Formation Fluid Density	:	9.5 ppg
Expected gas gradient	:	0.115 psi/ft
Depth of Production Intervals (TVD)	:	7350 - 7750 ft
Max. expected pressure grad. in production intervals	:	14 ppg
Packer fluid density	:	9 ppg
Design Factors		
(burst)	:	1.1
(collapse)	:	1.1

Casing Available (See attachment 1 for Specifications):

9 5/8" 47 lb/ft L-80 VAM
9 5/8" 53.5 lb/ft L-80 VAM

Note :

1. Gaslift may be used at a later stage in the life of this well. [12]
- (b) Describe the impact of tension on the collapse rating of casing [4]
- (c) List and discuss the functions of a conventional wellhead system. Describe how each of these functions are accommodated. [4]

B8

Whilst drilling the 8 1/2" hole section of a vertical well with a mudweight of 12 ppg the driller detects a kick. The well is shut in and the following information is gathered :

Surface Readings :

Shut in Drillpipe Pressure	:	600 psi
Shut in Annulus Pressure	:	750 psi
Pit Gain	:	20 bbls

Hole / Drillstring Data :

Hole Size	:	8 1/2 "
Depth of kick	:	8000 ft.
Previous Casing Shoe	:	9 5/8", 53.5 lb/ft
Depth 9 5/8" shoe	:	6500 ft. TVD
LOT at Previous shoe	:	4875 psi (0.75 psi/ft Equivalent Mudweight)

BHA :

Bit	:	8 1/2"
Drillcollars	:	300 ft of 6.25" x 2 13/16"
Drillpipe	:	5", 19.5 lb/ft

See attachment 2 for annular capacities

(a) Calculate and discuss the following :

- i. The type of fluid that has entered the wellbore ?
- ii. The mudweight required to kill the well.

[10]

(b) Briefly describe the "one circulation method" of killing a well.

[8]

(c) What precautions would you take to ensure that an influx could be controlled and killed if it occurred during drilling or during tripping?

[2]

B9

It has been decided to drill a well with a Type 1 (build and hold) profile. The well will be drilled to the following specifications:

Geographical Locations based on local grid :

Rig Location	:	N	8 350 000 ft
		E	400 000 ft
Target Location	:	N	8 346 500 ft
		E	397 000 ft
Target Depth (TVD)	:		8000 ft.
Kickoff Point	:		2500 ft.
Build up Rate	:		2.5° per 100 ft.

(a) Calculate the following :

- (i) the drift angle of the well.
- (ii) the TVD and horizontal deviation at the end of the build up section.
- (iii) the total measured depth to the target.

[12]

(b) List and discuss the considerations when designing the wellpath of a deviated wellbore.?

[5]

(c) List and discuss the advantages and disadvantages of using a gyroscope in place of a magnetic compass for measuring the direction of the borehole trajectory

[3]

B10

The 13 3/8" intermediate casing string of a well is to be cemented in place with a two stage cement job. The details of the job are as follows :

Previous Casing Shoe (20")	:	1800 ft.
13 3/8" 72 lb/ft Casing Setting Depth	:	5100 ft.
17 1/2" open hole Depth (Calipered @ 18" average)	:	5110 ft.
Multi-Stage Collar Depth	:	1750 ft.
Shoetrack	:	60 ft.

Cement stage 1 (5100-3300 ft.)

Class 'G' + 0.2% D13R (retarder)	:	15.8 ppg
Yield of Class 'G' + 0.2% D13R	:	1.15 ft ³ /sk
Mixwater Requirements	:	0.67 ft ³ /sk

Cement stage 2 (1750-1250 ft.)

Class 'G' + 8% bentonite + 0.1% D13R	:	13.2 ppg
Yield of Class 'G' + 8% bentonite + 0.1% D13R	:	1.89 ft ³ /sk
Mixwater Requirements	:	1.37 ft ³ /sk

(a) Calculate the following (See Attachment 2 for capacities):

- i. The required number of sacks of cement for the 1st stage and 2nd stage of the job (Allow 20% excess in open hole).
- ii. The volume of mixwater required for each stage.
- iii. The displacement volume for each stage.

[12]

(b) Write a cementing programme for the above operation.

(Note : Include in this programme any procedures/precautions which you think will ensure a good cement job).

[6]

(c) Suggest three reasons why a two stage cementing operation is conducted?

[2]

END OF PAPER

STRENGTH OF CASING

Casing	Burst Strength (psi)	Collapse Strength (psi)
9 5/8" 47 lb/ft L-80 VAM	6870	4750
9 5/8" 53.5 lb/ft L-80 VAM	7930	6620

VOLUMETRIC CAPACITIES

	bblsft	ft³/ft
Casing		
13 3/8" 72 lb/ft Casing:	0.1480	0.8314
Open Hole		
18" Hole	0.3147	1.7671
Annular Spaces		
20" Casing x 13 3/8" Casing	0.1815	1.0190
18" Hole x 13 3/8" Casing	0.1410	0.7914
8 1/2" hole x 6 1/4" drillcollars	0.0323	0.1895
8 1/2" hole x 5" drillpipe	0.045	0.258

HERIOT-WATT
UNIVERSITY
E d i n b u r g h

8 Pages

NAME: _____
REGISTRATION NO.: _____
COURSE: _____
YEAR: _____
SIGNATURE: _____

Complete this section but do not seal until the examination is finished

Date: _____

Subject: **Drilling Engineering**

INSTRUCTIONS TO CANDIDATES

	No.	Mk.
1. Complete the sections above but do not seal until the examination is finished.		
2. Insert in box on right the numbers of the questions attempted.		
3. Start each question on a new page.		
4. Rough working should be confined to left hand pages.		
5. This book must be handed in entire with the top corner sealed.		
6. Additional books must bear the name of the candidate, be sealed and be affixed to the first book by means of a tag provided		

PLEASE READ EXAMINATION REGULATIONS ON BACK COVER



Model Solutions to Examination

	SECTION A
1.a.	Cutting Structure (teeth):
	- Height and spacing of teeth:
	drillability/hardness of form
	- Soft formations require long widely spaced teeth.
	- Hard formation require short closely spaced teeth
	- Teeth hardfacing:
	abrasiveness of formation
	Bearings
	- size:
	large or small depends on WOB and rotating hours
	- sealed/non-sealed:
	sealed results in longer number of rotating hours
	- ball/roller/journal bearings:
	journal bearings are most resistant to wear and damage but this
	will depend on the planned WOB and rotating hours
	Cone Design
	- diameter of cone:
	will be controlled by the size of teeth, size of bearings, and
	requirement for mechanical cleaning in soft formations
	- meshing/interfit:
	requirement for cleaning



	- offset:
	high offset to give scraping action in soft formations
	no offset (no scraping) in hard formations.
	Fluid Circ.
	- number/position of nozzles:
	determines the distribution of flow over the bit face
	- centre jet:
	used mostly in very soft formations
	- extended nozzles:
	used mostly in soft formations
1b.	Performanc Criteria:
	ROP
	Length run
	Cost/ft
	i. ROP
	useful if run length of run not an issue (10 ft @ 100 ft/hr - good or bad?)
	ii. Length run
	useful if ROP not an issue (1000ft @ 1ft/hr - good or bad?)



2a.	The minimum mudweight is based on the pore pressure and borehole stability considerations and the maximum is based on the fracture pressure of the formation to be drilled.
	Formation pore pressure: - Minimum mudweight to avoid Influx
	- Include 200 psi overbalance over pore pressure
	- However, minimise overbalance to avoid-
	chip hold down
	differential sticking
	formation damage in reservoir
	Borehole Stability: - Minimum mudweight may depend on
	instability
	- Difficult to quantify analytically and
	may be based on experience
	Formation Frac. Pressure: - Max. mudwt. to avoid Lost Circulation
	- Less than Geostatic Pressure (1.0 psi/ft)



3a.	(List any four of the following)
	<p>Flow Rate Increase - While the mud pumps are circulating at a constant rate there should be a steady flow rate of mud returns. If this flowrate increases (without changing the pump speed) this is a sign that formation fluids are feeding into the wellbore and helping to move the contents of the annulus to the surface.</p>
	<p>Pit Volume Increase - A rise in the level of mud in the active pits is a sign that some mud has been displaced from the annulus by an influx of formation fluids. The volume of this influx is equal to the pit gain and should be noted for use in later calculations.</p>
	<p>Flowing Well with Pumps Shut Off - When the rig pumps are not operating there should be no returns. If the pumps are shut down and the well continues to flow it must be due to a kick. (There are 2 exceptions to this rule (a) thermal expansion of mud in the annulus and (b) U tubing effect when mud in drillstring is heavier than mud in annulus). A flow check is often carried out to confirm whether the well is kicking or not.</p>
	<p>Improper Hole Fill-Up During Trips - As mentioned earlier the hole should require to be filled when pipe is tripped out. If it does not take the calculated volume the drillpipe volume has already been replaced by formation fluids</p>

Model Solutions to Examination

	Changes in Pump Pressure - An entry of formation fluids may cause the mud to flocculate and result in a slight increase in pump pressure. As flow continues the lower density of the influx will cause a gradual drop in pump pressure. As the fluid in the annulus becomes lighter the mud in the drillpipe will tend to fall and the pump speed (strokes per min.) will increase. Notice, however, that these effects can be caused by other drilling problems (e.g. washout in drillstring, or twist-off).
	Gas Cut Mud - This may be considered as an early warning sign. The mud should be continuously monitored. Any significant rise above background level should be reported. Gas cutting may occur due to:
	(i) drilling in a gas bearing formation with the correct mud weight
	(ii) swabbing when making a connection or during trips
	(iii) influx due to negative pressure differential.
	The detection of gas in the mud does not necessarily mean the weight should be increased. The cause of the gas cutting should be investigated before action is taken.
	Drilling Break - An abrupt increase in the rate of penetration should be treated with caution. If drilling parameters have not been changed the increased penetration rate may be attributed to
	(i) change from shale to sand (more porous and permeable and so having a greater kick potential) or

Model Solutions to Examination

4a.	OBM
	Advantages
	- Shale Drilling (Inhibition)
	- Lubrication (in extended reach) wells
	- Produces Gauge hole (for cementing)
	- Reduces Corrosion
	- Creates a Thin Mud Cake (preventing diff. stick)
	- Increased ROP
	- Minimises Reservoir damage
	Disadvantages
	- High Cost
	- Environmentally sensitive
	- Complex formulation
	- Poor Temp. Stability
	- Kick detection difficult
	- Special logging tools required
	- Rheological control difficult
	- Rig Modifications to prevent Leaks
	- Removal when cementing is difficult
4b.	(Two of the Following)
	Mud density
	A sample of mud is weighed in a mud balance. The cup of the balance is completely filled with mud and the lid placed firmly on top. (Some mud should escape through the hole in the lid). The balance arm is placed on the base and the rider adjusted until the arm is level. The density



	can be read directly off the graduated scale at the left-hand side of the rider.
	Mud densities are usually reported to the nearest 0.1 ppg (lbs per gallon). Other units in common use are lbs/ft ³ , psi/ft, psi/1000ft, kg/l and specific gravity (S.G.).
	Viscosity
	Two common methods are used on the rig to measure viscosity:
	Marsh funnel: This is a very quick test which only gives an indication of viscosity and not an absolute result. The funnel is of standard dimensions (12" long, 6" diameter at the top, 2" long tube at the bottom, 3/16" diameter). A mud sample is poured into the funnel and the time taken for one quart (946 ml) to flow out into a measuring cup is recorded. (Fresh water at 75oF has a funnel viscosity of 26 sec/quart.) Since the flow rate varies throughout this test it cannot give a true viscosity. Non-newtonian fluids (i.e. most drilling fluids) exhibit different viscosities at different flow rates. However the funnel viscosity can only be used for checking radical changes in mud viscosity. Further tests must be carried out before any treatment can be recommended.
	Rotational viscometer (Figure 6): This device gives a more meaningful measure of viscosity. A sample of mud is sheared at a constant rate between a rotating outer sleeve and an inner bob. The test is conducted at a range of different speeds, 600 rpm, 300 rpm, 100 rpm

Model Solutions to Examination

etc.	(laboratory models can operate at 6 different speeds). The standard procedure is to lower the instrument head into the mud sample until the sleeve is immersed up to the scribe line. The rotor speed is set at 600 rpm and after waiting for a steady dial reading this value is recorded (degrees). The speed is changed to 300 rpm and again the reading is recorded. This is repeated until all of the required dial readings have been recorded. The results can be plotted and assuming that there is a linear relationship between shear stress and shear rate (i.e. Bingham plastic) the following parameters can be calculated from the graph:
	Plastic Viscosity (PV) = D600 - D300 (centipose)
	Yield Point (YP) = D300 - PV (lb/100 ft ²)
	Gel Strength
	A third property is used to describe the attractive forces while the mud is static. This is called "gel strength". Gel strength can be thought of as the stress required to get the mud moving. The gel strength can be measured using the viscometer. After the mud has remained static for some time (10 secs) the rotor is set at a low speed (3 rpm) and the deflection noted. This is reported as the "initial or 10 second gel". The same procedure is repeated after the mud remains static for 10 minutes, to determine the "10 minute gel". Both gels are measured in the same units as Yield Point (lbs/100ft ²). Gel strength usually appears on the mud report as two figures (e.g. 17/25). The first being the initial gel and the second the 10 minute gel.



5a.	
- Position the rig	- Towed (Semis) or self propelled (ships), set anchors or establish d.p. and perform seabed inspection,
- Run TGB	- run on d.p., 4 guidewires (3/4" dia), has 46" hole through the centre
- Drill 36" hole	- bit plus h.o. run with UGF
- Run PGB and 30" csg	- run together
- Cement 30" Csg.	
- Rig up Diverter*	- consists of latch, uniflex joint, riser, telescopic joint, diverter
- Drill 26" hole	
- Rig down diverter**	
- Run HPWHH with 20" Csg,	- High pressure housing on top of 20" casing
- Cement 20" csg	
- Run BOP stack-up***	- BOP (hydraulic connector, BOP Rams, Hydril), LMRP (Hydraulic connector, Ann. preventer plus uniflex joint) Riser and telescopic joint
- Drill 17 1/2" hole, run cement 13 3/8" Csg] All casings land and
- Drill 12 1/4" hole, run and cement 9 5/8" Csg] seal inside 20" hp

Model Solutions to Examination

		wellhead housing
	* No diverter - flow at seabed, possible listing of rig with diverter - gas flow at surface, possible washout and ignition	
	** Well exposed - may run logs over open hole before removing diverter.	
	*** BOP on well until all casings set and cemented.	
	b. The major differences between the subsea wellhead and surface systems are:	
	<u>Component/Function</u>	<u>Subsea</u> <u>Surface</u>
	BOP	on seabed at surface
	casing supported	on seabed at surface
	annulus access	only between tubing all annuli
		and prod. casing, none
		between casings
	annulus seal	all at seabed all at surface
	configuration	13 3/8", 9 5/8" and 7 " stack up of spools
		land inside HPWHH
	BOP removal	BOP in place from remove and replace
		landing HPWHH BOP on every
		spool.

6a. Subsurface:

Sensors

GR, Resistivity, WOB, RPM, Direction
(azimuth and inclination)

Transmitter :

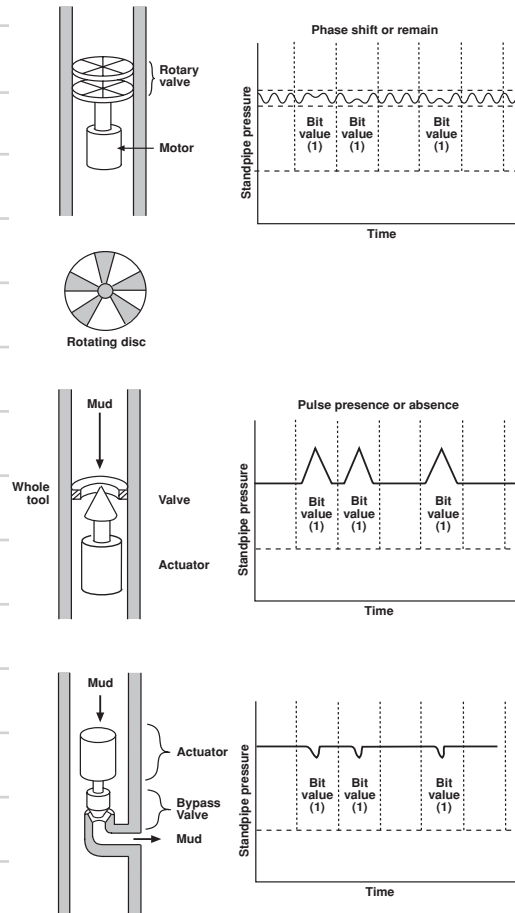

Power Source:

Power Source	Advantages	Disadvantages
Batteries (Li)	Compact	Temp. Limit (150° C) Time Limit (100 to 800 hrs)
Turbine	Higher Power Output than Batteries Unlimited Operating Time	Filters Required

Surface:

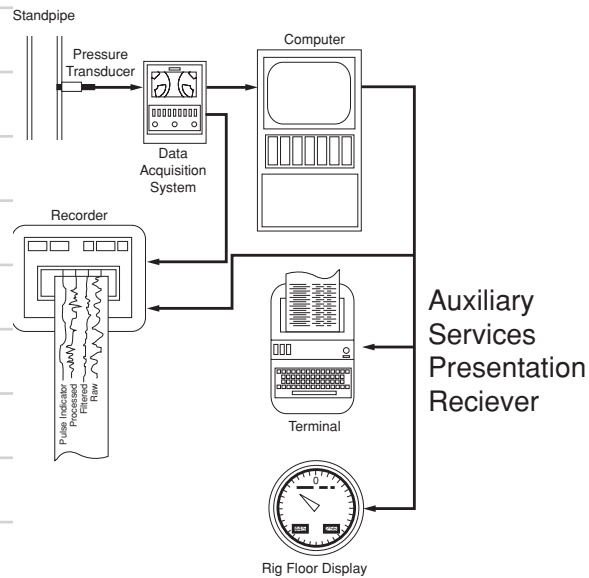

6b. (Four of the following)

MWD tools are very useful for real time identification of the formations which have just been drilled. If not available can only determine position geologically by circ. bottoms up to retrieve cuttings. This is very time consuming. The tool is therefore widely used for:

- Core point selection
- Casing point selection (when precise placement required)
- Formation correlation when geosteering to stay in the reservoir

They are used to replace wireline logging operations saving time and money.

They are most widely used to provide real time information on bit trajectory (Directional Control) providing more frequent surveys and saving time and money over the conventional survey techniques.

Model Solutions to Examination

	CITHP (at surface) = Pressure at Top of Perfs - pressure due to				
	colom of gas (0.115 psi/ft)				
	= 5351 - 0.115 x 7350				
	= 4506 psi				
	Pressure at Top of Packer = CITHP+ hydrostatic colom of packer fluid				
	= 4506 + (9 x 0.052 x 7200)				
	= 7876 psi				
	External Load: Assuming that the minimum pore pressure is acting at				
	the packer depth and zero pressure at surface.				
	Pore pressure at the Packer				
	= 9.5 x 0.052 x 7200				
	= 3557 psi				
	External pressure at surface = 0 psi				
	SUMMARY OF BURST LOADS				
	DEPTH EXT. LOAD INT. LOAD NET LOAD DESIGN LOAD				
	(LOAD X 1.1)				
	Surface	0	4506	4506	4957
	Packer	3557	7876	4319	4751
	(7200 ft)				



Collapse Design - Drilling					
Internal Load: Assuming that the casing is totally evacuated due to gaslifting operations					
Internal Pressure at surface = 0 psi					
Internal Pressure at Top of Packer = 0 psi					
External Load: Assuming that the maximum pore pressure is acting on the outside of the casing at the Packer					
Pore pressure at the Packer = $9.5 \times 0.052 \times 7200$					
= 3557 psi					
External pressure at surface = 0 psi					
SUMMARY OF COLLAPSE LOADS					
DEPTHEXT. LOAD INT. LOAD NET LOAD DESIGN LOAD					
(LOAD X 1.1)					
Surface	0	0	0	0	0
Packer	3557	0	3557	3913	
(7200 ft)					
CASING SELECTED 9 5/8" 47 LB/FT L-80 VAM					

Model Solutions to Examination

B1 b. It has been established that an axial load can affect the burst and collapse ratings of casing. This is represented in the Figure below. It can be seen that as the tensile load imposed on a tubular increases the collapse rating decreases and the burst rating increases. It can also be seen from this diagram that as the compressive loading increases the burst rating decreases and the collapse rating increases. The burst and collapse ratings for casing quoted by the API assume that the casing is experiencing zero axial load. However, since casing strings are very often subjected to a combination of tension and collapse loading simultaneously, the API has established a relationship between these loadings.

The Ellipse shown in the Figure below is in fact a 2D representation of a 3D phenomenon. The casing will in reality experience a combination of three loads (Triaxial loading). These are Radial, Axial and Tangential loads. The latter being a resultant of the other two.

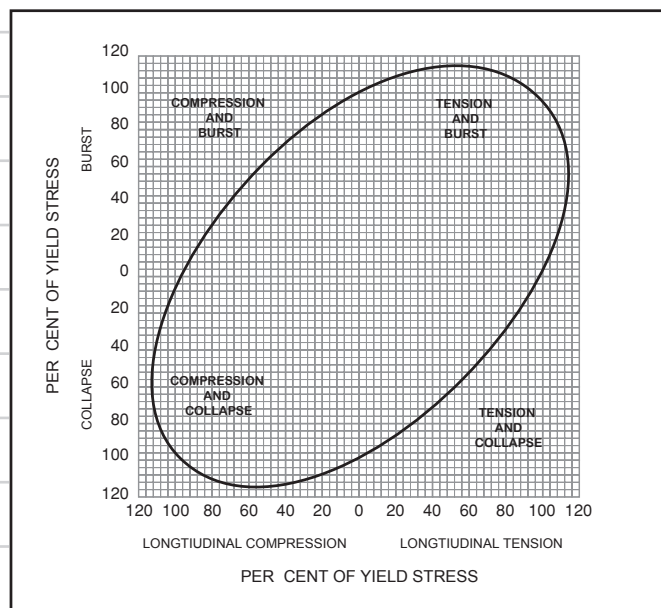

B2 a.

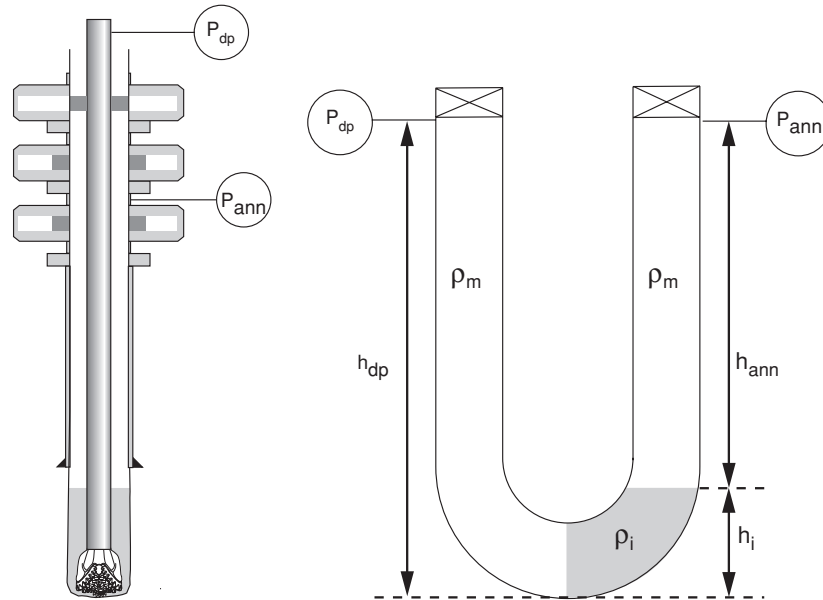

(i) KILL MUDWEIGHT

$$\begin{aligned} \text{Bottom hole press} &= (8000 \times 12 \times 0.052) + 600 \\ &= 5592 \text{ psi} \end{aligned}$$

$$\begin{aligned} \text{kill mud} &= 5592/8000 \\ &= 0.699 \text{ psi/ft} \\ &= 13.44 \text{ ppg} \end{aligned}$$

(if 200 psi overbalance is added kill mudweight = 0.724 psi/ft)

With 200 psi overbalance the kill mudweight is close to the LOT pressure at the previous shoe.

Model Solutions to Examination

B2 b.	The one circulation method can be divided into 4 phases (See Figure B2.1).
	Phase I (displacing drillstring to heavier mud)
	As the driller starts pumping the kill mud down the drillstring the choke is opened. The initial circulating pressure will be P_{c1} . The choke should be adjusted to keep the standpipe pressure decreasing until all of the drillpipe is full of killweight. In fact the pressure is reduced in steps by maintaining standpipe pressure constant for a period of time, then opening it more to allow the pressure to drop in regular increments. Once the heavy mud completely fills the drillstring the stand pipe pressure should become equal to P_{c2} . The pressure on the annulus usually increases during phase I due to the reduction in hydrostatic pressure caused by gas expansion in the annulus.
	Phase II (pumping heavy mud into the annulus until influx reaches the choke)
	During this stage the choke is adjusted to keep the standpipe pressure constant (i.e. standpipe pressure = P_{c2}). The annulus pressure will vary more significantly than in phase I due to 2 effects:
	(i) the increased hydrostatic head due to the heavy mud will tend to reduce P_{ann} .
	(ii) if the influx is gas, the expansion will tend to increase P_{ann} due to the decreased hydrostatic head in the annulus.



	The profile of annulus pressure during phase II therefore depends on the nature of the influx (see Figure B2.2).
	Phase III (time taken for all the influx to be removed from the annulus)
	As the influx is allowed to escape the hydrostatic pressure in the annulus will increase due to more heavy mud being pumped through the bit to replace the influx. Therefore, P_{ann} will reduce significantly. If the influx is gas this reduction may be very severe and cause vibrations which may damage the surface equipment (choke lines and choke manifold should be well secured). As before the standpipe pressure should remain constant.
	Phase IV (stage between all the influx being expelled and heavy mud reaching surface)
	During this phase all the original mud is circulated out of the annulus and is replaced by a full column of heavy mud. The annulus pressure will reduce to 0, and the choke should be fully open. The standpipe pressure should be equal to P_{c2} . To check that the well is finally dead the pumps can be stopped and the choke closed. The pressures on drillpipe and annulus should be 0 (if not continue circulating). When the well is dead open the annular preventer, circulate and condition the mud prior to resuming normal operations. (A trip margin of 0.2 - 0.3 ppg may be added to the mud weight to allow for swabbing effects when pulling out of hole).

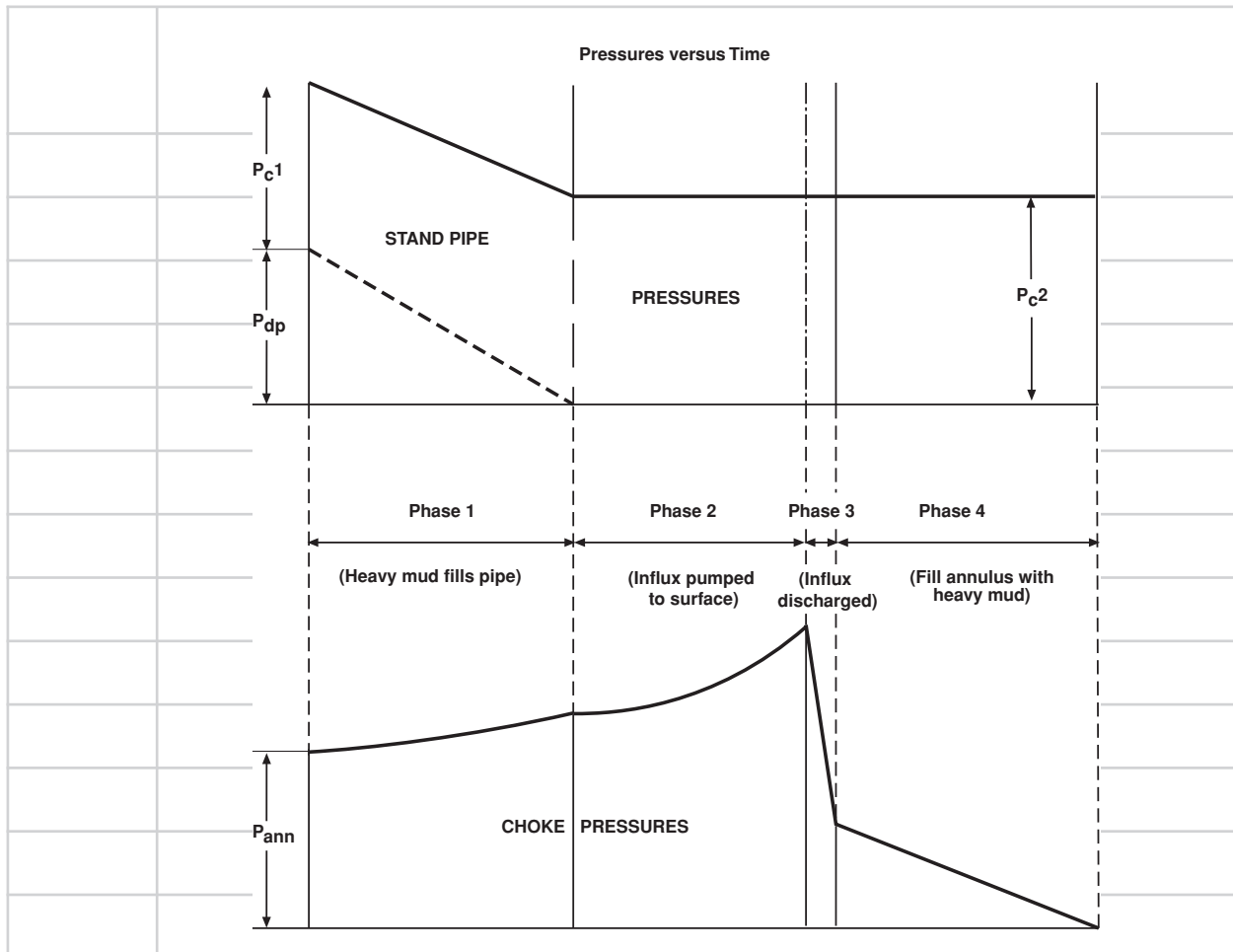

Figure B2.1

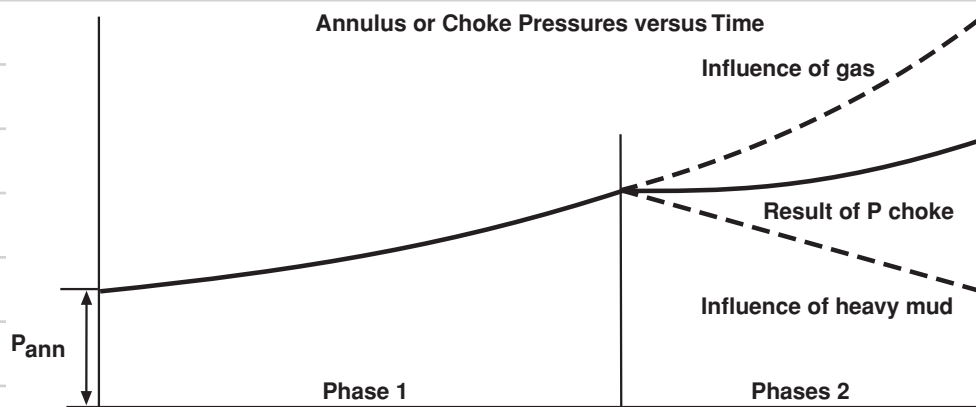
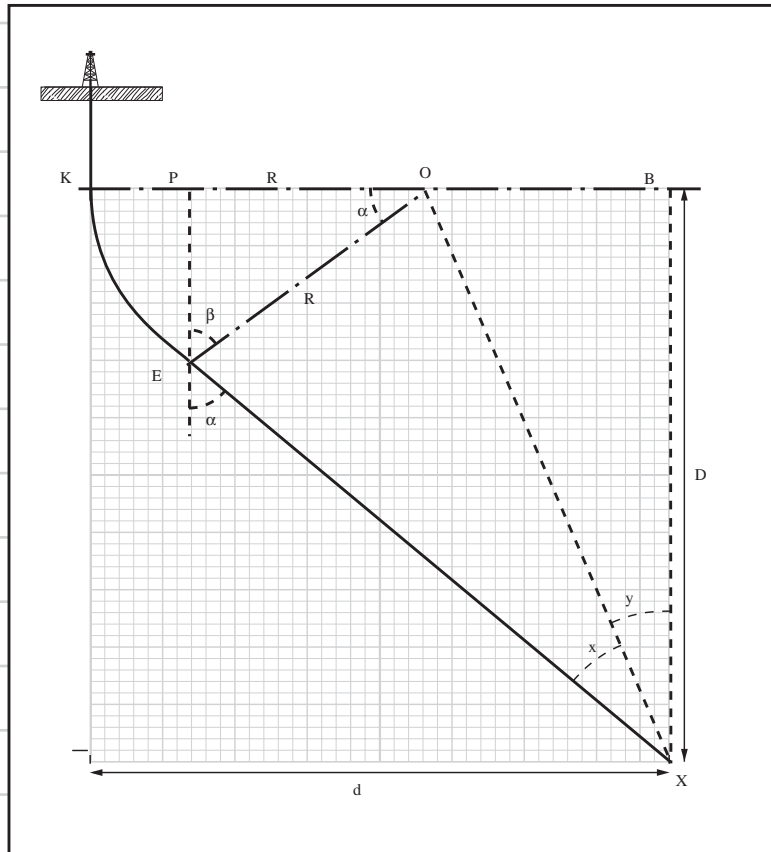

Figure B2.2

B3a

Calculate displacement of target:



$$\begin{aligned} \text{Displacement} &= \sqrt{3000^2 + 3500^2} \\ &= 4610 \text{ ft} \end{aligned}$$

a. DRIFT ANGLE:

$$\frac{2.5 R}{100} = \frac{360}{2\pi}$$



	$R = \frac{360 \times 100}{5.0 \times \pi}$	(Radius of BU Section)
	$= 2292 \text{ ft}$	
(i)	$\text{Tan } \gamma = \frac{4610 - 2292}{5500}$	$= \frac{2318}{5500}$
	$\gamma = 22.85^\circ$	
(ii)	$\text{Sin } \gamma = \frac{OB}{OX}$	$= \frac{2318}{OX}$
	$OX = 5969.3 \text{ ft}$	
(iii)	$\text{Sin } x = \frac{R}{OX}$	
	$= \frac{2292}{5969}$	
	$x = 22.6^\circ$	
	$\alpha = x + \gamma$	
	$= 45.4^\circ$	(Drift/Tangent Angle)

Model Solutions to Examination

b.	TVD and Displacement
	$\beta = 180 - 90 - \alpha$
	$= 44.6^\circ$
	$\cos \beta = \frac{PE}{EO} = 0.712$
	$PE = 1632$
	$TVD (E) = 4132 \text{ ft}$
	$\sin \beta = \frac{PO}{R}$
	$PO = 1609 \text{ ft}$
	$KP = KO - PO$
	$= 2292 - 1609$
	$= 683 \text{ ft}$
	$Displacement (E) = 683 \text{ ft}$



c.	Total Along Hole Depth
	$\frac{\alpha}{360} = \frac{KE}{2\pi \times 2292}$
	$0.1261 = \frac{KE}{14401}$
	$KE = 1816 \text{ ft}$
	Total AH = 2500 + 1816 + EX
	EX = OX cosx
	= 5969 × 0.7022
	= 551 ft
	Total AH depth = 9826.64 ft
B3 b.	Formations (BUR, hole angle):
	Borehole Stability, mud requirements Casing scheme , KOP, Doglegs,
	Shape, Max. Angle, BUR
	Specification of Target, Size and Shape
	The location, size and shape of the target is usually chosen by
	geologists and/or reservoir engineers. They will give the geographical

Model Solutions to Examination

	co-ordinates, true vertical depth and specify the size of the
	target(e.g. radius of 100'). In general the smaller the target area, the
	more directional control required, and so the more expensive the well
	will be.
	Rig Location
	The position of rig must be considered in relation to the expected
	geological strata to be drilled (e.g. salt domes, faults etc.). When
	developing a field from a fixed platform the location is critical in order
	to cover the full extent of the reservoir.
	Location of Adjacent Wells
	Drilling close to an existing well is highly dangerous. This is especially
	true on offshore platforms where the wells are very closely spaced.
	The proposed well must be deflected or nudged away from all adjacent
	wells.
	Casing and Mud Programmes
	In highly deviated wells rubber drillpipe protectors may be installed to
	prevent casing wear. To avoid drilling problems the mud properties
	have to be monitored closely. Some operators prefer to use oil based
	mud in directional holes to provide better hole conditions.
	Hole Size
	Larger hole diameters are preferred since there is less natural
	tendency to deviate, resulting in better control of the well path.

Model Solutions to Examination

5b.	Gyroscope
	Advantages
	Use in pipe/casing
	no monels required
	accurate
	provides true north
	Disadvantages
	complicated tool
	requires surface alignment
	Magnetic Compass:
	Advantages
	simple
	requires monel collars
	cheap
	Disadvantages
	can't use in csg./pipe
	magnetic not true north



B4.a.

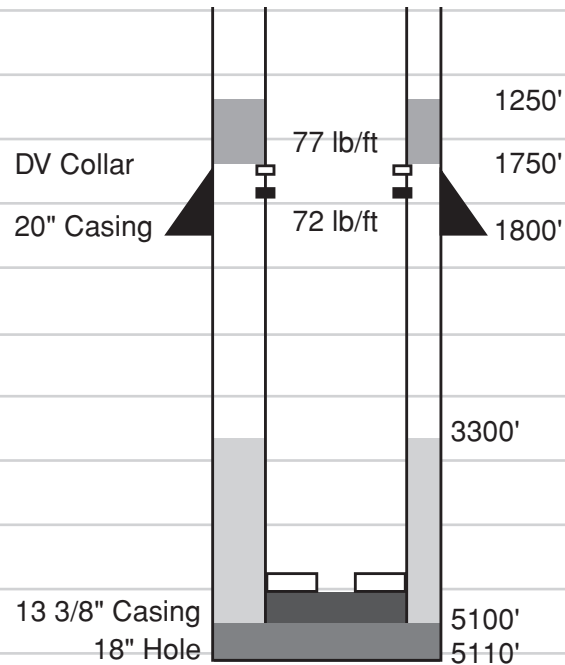

a. No. sxs cement

Stage 1:

Slurry volume between the casing and hole:

13 3/8" csg/ 17 1/2" hole capacity = 0.7914 ft³/ft

annular volume = 1800 × 0.7914

= 1425 ft³

plus 20% excess = 285 ft³

Total = 1710 ft³

Slurry volume below the float collar:

Cap. of 13 3/8, 72 lb/ft csg = 0.8314 ft³/ft

shoetrack vol. = 60 × 0.8314

Total = 50 ft³

Model Solutions to Examination

	Slurry volume in the rathole:	
	Cap. of 17 1/2" hole	= 1.7617 ft ³ /ft
	rathole vol.	= 10 × 1.7617
		= 17.6 ft ³
	plus 20%	= 3.5 ft ³
	Total	= 21.1 ft ³
	TOTAL SLURRY VOL. STAGE 1 :	1781 ft³
	Yield of class G cement for density of 15.8 ppg	= 1.15 ft ³ /sk
	TOTAL No. SXS CEMENT STAGE 1:	1781/1.15 = 1549 sxs
	Stage 2:	
	20" csg/ 13 3/8" csg	= 1.019 ft ³ /ft
	annular volume	= 500 × 1.019
		= 510 ft ³
	TOTAL SLURRY VOL. STAGE 2 :	510 ft³
	Yield of class G cement for density of 13.2 ppg	= 1.89 ft ³ /sk
	TOTAL No. SXS CEMENT STAGE 2:	510/1.89 = 270 sxs



b.	Amount of mixwater
	Stage 1:
	mixwater requirements for class G cement for density of 15.8 ppg
	= 0.67 ft ³ /sk
	Mixwater required = 1549 × 0.67
	= 1038 ft³
	Stage 2:
	mixwater requirements for class G cement for density of 13.2 ppg
	= 1.37 ft ³ /sk
	Mixwater required = 270 × 1.37
	= 370 ft³
c.	Displacement Volumes
	Stage 1:
	Displacement vol. = vol between cement head and float collar
	= 0.148 (bbl/ft) × 5040 = 746 bbl
	(add 2 bbl for surface line) = 748 bbl
	Stage 2:
	Displacement vol. = vol between cement head and stage collar

Model Solutions to Examination

	= 0.148 (bbl/ft) × 1750 = 259 bbl
	(add 2 bbl for surface line) = 261 bbl
B4. b.	
	Run casing with centralisers and possibly scratchers
	Circulate casing contents (x 2)
	First stage - The procedure is similar to that for a single stage operation, except that no wiper plug is used ahead of the cement :
	* pump spacer ahead of cement
	* pump cement
	* release shut-off plug
	* displace with spacer and low yield mud
	A smaller volume of slurry is used, so that only the lower part of the annulus is cemented and only a second wiper plug is used. The height of this cemented part of the annulus will depend on the fracture gradient of the formation (a height of 3000' - 4000' above the shoe is common).
	Second stage - This involves the use of a special tool known as a stage collar, which is made up into the casing string at a pre-determined position. (The position may be fixed by the depth of the previous casing shoe.) There are ports in the stage collar which are initially closed by an inner sleeve, held by retaining pins. After the first stage

Model Solutions to Examination

	The quality of a cement job can generally be improved by :
	* centralising the casing - most important
	*reciprocating or rotating the casing - not possible to rotate in most cases (except for liners) but reciprocation is quite common.
	* circulating spacers- formulated so that they induce turbulence
	* circulating at a high velocity - to ensure total mud removal
	One disadvantage of stage cementing is that the casing cannot be moved after the first stage cement has set in the lower part of the annulus. This increases the risk of channelling and a poor cement bond.
4 c.	The two stage operation are used to reduce the height of heavy weight cement column in the annulus. This may be done for several reasons:
	i) to reduce the total hydrostatic head on the bottom of the hole and therefore prevent lost circulation when cementing. Lost circulation may result in the TOC being too low and problem formations being exposed in the annulus.
	ii) to ensure that cement is placed across the previous casing shoe. This may be required when abandoning the well. Without a two stage operation the entire openhole section of the annulus would have to be cemented.
	iii) To reduce the amount (and therefore cost) of cement used.

Drilling Engineering Past Papers

Please note some questions in these past papers are no longer relevant, those questions have been highlighted in grey bold italics.



**HERIOT-WATT UNIVERSITY
DEPARTMENT OF PETROLEUM ENGINEERING**

**Examination for the Degree of
MEng in Petroleum Engineering**

Drilling Engineering

**Thursday 7 January 1999
09.30 - 12.30**

NOTES FOR CANDIDATES

1. This is a Closed Book Examination.
2. 15 minutes reading time is provided from 09.15 - 09.30.
3. Examination Papers will be marked anonymously. See separate instructions for completion of Script Book front covers and attachment of loose pages. Do not write your name on any loose pages which are submitted as part of your answer.
4. This Paper consists of 3 Sections:- A, B and C.
5. Section A:- Attempt 4 numbered Questions
Section B:- Attempt 1 numbered Question
Section C:- Attempt 3 numbered Questions
6. Section A:- 32% of marks [8% per Question]
Section B:- 8% of marks
Section C:- 60% of marks [20% per Question]

Marks for Question parts are indicated in [brackets]

7. This Examination represents 100% of the Class assessment.
8. State clearly any assumptions used and intermediate calculations made in numerical questions. No marks can be given for an incorrect answer if the method of calculation is not presented.
9. Answers must be written in separate, coloured books as follows:-

Section A:- Blue
Section B:- Green
Section C:- Yellow

Section A

A1

- (a) List and describe the function of each of the component parts of the hoisting system on a conventional land drilling rig. [5]

- (b) Calculate the tension on the fast line and the dead line and the vertical load on the derrick when the following drillstring is pulled from the well.

Buoyant weight of string	150,000 lbs
Weight of travelling Block and hook	10,000 lbs
Number of Lines strung between crown and travelling block	8
Efficiency of sheave system	81.4%

[3]

A2

- (a) Describe three reasons for using Drillcollars in the drillstring string. [5]

- (b) Calculate, using the tables provided in Attachment 1, the length of 9 1/2" x 2 13/16" drillcollars that would be required to ensure that the entire length of the following drillpipe string is in tension in 12 ppg mud:

8000 ft of 5" 19.5 lb/ft Grade G drillpipe with 4 1/2" IF connections.

[3]

A3

- (a) Describe the mechanisms which result in an improvement in the "drillability" of an overpressured formation and which should be considered when calculating the "d" exponent. [4]

- (b) List and describe three other indicators, other than the "d" exponent, which might suggest that an overpressured shale had been encountered.

[4]

A4

- (a) A milled tooth roller cone drillbit is pulled from the borehole and graded with the following grading (the IADC dull grading system is given in Attachment 2).

4 4 BT A F 1/8 PB PR

Discuss your interpretation of this grading and what features you would suggest should be considered in selecting the next bit to be run in the well.

[3]

- (b) Calculate the cost per foot of the bit run on the basis of the following information:

COST	DEPTH	DEPTH	TIME ON
(£)	IN	OUT	BOTTOM
	(FT.)	(FT.)	(HR.)
3500	7100	7306	14.9

Assuming:

Trip Time = 8 hrs

Rig rate = £48000/day.

[2]

- (c) In what ways is the cost per foot equation used when planning the well and during the well drilling operation

[3]

A5

(a) List the steps in the procedure for conducting a leak off test.

[2]

(b) The results from a Leak off test which has been conducted below the 9 5/8" casing shoe of a well are presented below. Calculate the maximum allowable mudweight which can be used in the hole section below the 9 5/8" casing shoe:

TVD of 9 5/8" Shoe : 6500 ft.
Mudweight in hole : 10 ppg

Vol. pumped bbls	Surface Pressure psi
0.5	30
1.0	110
1.5	205
2.0	295
2.5	390
3.0	475
3.5	570
4.0	655
4.5	760
5.0	800
5.25	820

[4]

(c) Calculate the MAASP for the subsequent hole section when the mud weight is 11 ppg.

[2]

A6

- (a) List and briefly describe three of the warning signs that a driller should see if a gas influx had occurred downhole. [4]
- (b) Describe the operations which must be undertaken when a kick is detected whilst drilling. [3]
- (c) In the case of a gas influx, why must the well killing operation be started as soon as possible? [1]

Section B

B7 For a given depth, well orientation and rock type, it is usually possible to select a mud weight which is appropriate from a rock mechanics point of view, i.e. wellbore failure is prevented. Explain why this is possible, addressing all types of wellbore failure in your answer.

[8]

B8 Tests conducted on a rock type gave the following data:

<i>Triaxial factor</i>	<i>2.8</i>
<i>In situ strength enhancement</i>	<i>0.10MPa</i>
<i>In situ unconfined compressive strength</i>	<i>4MPa</i>

Determine the minimum mud weight required to prevent wellbore failure in this rock while drilling through it at 5000m depth with a vertical well, where the pore pressure is 60MPa and the stress ratio is 0.85. A data sheet (Attachment 5) is provided.

[8]

Section C

C9

(a) Describe the main factors which influence the pressure loss when circulating fluid through the drillstring and annulus when drilling? [6]

(b) How is the onset of turbulence identified when using non-Newtonian drilling fluids in annuli? [4]

(c) Select the optimum flowrate and nozzle sizes for the next bit run if prior to pulling a dulled bit from the hole the pressure losses in the circulation system are calculated to be as follows :

Flowrate GPM	P _{total} psi	P _{bit} psi	P _{circ.} psi
860	4400	2400	2000
680	2890	1590	1300
500	1650	910	740
350	845	465	380

Density of Drilling Fluid = 0.65 psi/ft.

Maximum Pumping Pressure = 4700 psi

Note: i. Use the attached log-log paper and Table 1 and 2 (Attachment 3)

ii.
$$\text{Nozzle Area} = \frac{Q_{\text{opt}}}{23.75} \sqrt{\frac{\rho_{\text{mud}}}{P_{\text{max.}} - P_{\text{circ.opt.}}}}$$
 [7]

(d) Describe the way in which the pressure losses in the system change as the hole section is deepened and how this affects the optimisation of the hydraulics of the system. [3]

C10

(a) State the principal functions of the following casing strings:

conductor;
surface;
intermediate; and
production casing.

[8]

(b) Calculate the burst and collapse loading which will be used in the selection of casing for the following production casing string:

Top of Production Packer	:	7200 ft
Formation Fluid Density	:	9 ppg
Expected gas gradient	:	0.115 psi/ft
Depth of Production Interval (TVD)	:	7350-7750ft
Max. expected pressure in production intervals	:	3700 psi
Packer fluid density	:	9 ppg
Design Factors (burst)	:	1.1
(collapse)	:	1.0

Note : Gaslift may be used at a later stage in the life of this well.

[10]

(c) Describe the effect of tensile loading on the burst and collapse rating of casing?

[2]

C11

(a) Describe, with the aid of diagrams, the Tangential and Balanced tangential mathematical models used to describe and calculate the trajectory of a well.

[5]

(b) What are the sources of error when determining the position of the wellbore.

[3]

(c) Whilst drilling a deviated well to a target at 11000 ft. TVD. The following data is recorded at station No. 37 (The target bearing is 132°)

STATION	MD	INC.	AZI.	N	E	TVD	VS
36	8400	35	124	-328	1044	7900	1005
37	8600	38	125				

Calculate the North and East co-ordinates, TVD and vertical section of station No. 37 using the average angle method.

[12]

C12 The 13 3/8” intermediate casing string of a well is to be cemented in place with a two stage cement job. The details of the job are as follows :

Previous Casing Shoe (20”)	:	1800 ft
13 3/8” 72 lb/ft Casing Setting Depth	:	5100 ft
17 1/2” open hole Depth (Calipered @ 18” average)	:	5130 ft
Multi-Stage Collar Depth	:	1750 ft
Shoetrack	:	60 ft

Cement stage 1 (5100-3300 ft.)

Class ‘G’ + 0.2% D13R (retarder)	:	15.8 ppg
Yield of Class ‘G’ + 0.2% D13R	:	1.15 ft ³ /sk
Mixwater Requirements	:	0.67 ft ³ /sk

Cement stage 2 (1750-1250 ft.)

Class ‘G’ + 8% bentonite + 0.1% D13R	:	13.2 ppg
Yield of Class ‘G’ + 8% bentonite + 0.1% D13R	:	1.89 ft ³ /sk
Mixwater Requirements	:	1.37 ft ³ /sk

- (a) Calculate the following (See Attachment 4 for capacities):
- (i) The required number of sacks of cement for the 1st stage and 2nd stage of the job (Allow 20% excess in open hole).
 - (ii) The volume of mixwater required for each stage.
 - (iii) The displacement volume for each stage.
- [10]
- (b) Calculate the static bottomhole pressures generated during the above cementing operations.
- [2]
- (c) Would the above pressure accurately represent the pressures on the bottom of the well when the cementing operation is being conducted?
- [2]
- (d) Prepare a program for a two stage cementing operation and describe the ways in which a good cement bond can be achieved.
- [6]

End of Paper

CAPACITY AND DISPLACEMENT OF DRILLPIPE

SIZE AND CONN.	NOMINAL WEIGHT LB/FT	GRADE	APPROX WEIGHT LB/FT	CAPACITY		OPEN END DISPLACEMENT		CLOSED END DISPLACEMENT	
				L/M	GALL/FT	L/M	GALL/FT	L/M	GALL/FT
2 ³ / ₈ 2 ³ / ₈ IF NC26	6.65	E75	7.00	1.68	0.135	1.39	0.107	3.01	0.242
		X95	7.08			1.34	0.108	3.02	0.243
		G105	7.08			1.34	0.108	3.02	0.243
2 ⁷ / ₈ 2 ⁷ / ₈ IF NC 31	10.4	E75	10.82	2.36	0.190	2.05	0.165	4.41	0.355
		X95	10.89			2.06	0.166	4.42	0.356
		G105	10.89			2.06	0.166	4.42	0.356
		S135	11.20			2.12	0.171	4.48	0.361
3 ¹ / ₂ 3 ¹ / ₂ IF NC38	9.5	E75	10.39	4.54	0.366	1.97	0.159	6.51	0.525
	13.3	E75	13.86	3.88	0.312	2.63	0.212	6.51	0.524
		X95	14.32	3.96	0.319	2.71	0.218	6.67	0.537
15.5	G105	14.38	3.87	0.312	2.73	0.220	6.60	0.532	
	E75	16.42	3.46	0.279	3.11	0.250	6.57	0.529	
5 4 ¹ / ₂ IF NC50	19.5	X95	21.09	9.16	0.738	4.00	0.322	13.16	1.070
		G105	21.50			4.08	0.329	13.24	1.087
25.6	E75	S135	22.09	8.11	0.653	4.19	0.337	13.35	1.075
		X95	27.01			5.12	0.412	13.23	1.065
		G105	28.30			5.36	0.432	13.46	1.084
			28.11	8.09	0.651	5.33	0.429	13.42	1.080

1 Barrel = 42 US Gallons

DRILL COLLAR WEIGHTS (STEEL) POUNDS PER FOOT

lbs/ft = 2.67 (OD² - ID²)

Collar O.D.	BORE OF COLLAR										
	1- ¹ / ₂	1- ³ / ₄	2	2- ¹ / ₄	2- ¹ / ₂	2- ¹³ / ₁₆	3	3- ¹ / ₄	3- ¹ / ₂	3- ³ / ₄	4
3- ³ / ₈	24.4	22.2									
3- ¹ / ₂	26.7	24.5									
3- ³ / ₄	31.5	29.3									
3- ⁷ / ₈	34.0	31.9	29.4	26.5							
4	36.7	34.5	32.0	29.2							
4- ¹ / ₈	39.4	37.2	34.7	31.9							
4- ¹ / ₄	42.2	40.0	37.5	34.7							
4- ¹ / ₂	48.0	45.8	43.3	40.5							
4- ³ / ₄	54.2	52.0	49.5	46.7	43.5						
5	60.2	58.5	55.9	53.1	49.9						
5- ¹ / ₄	67.5	65.3	62.8	59.9	56.8	53.3					
5- ¹ / ₂	74.7	72.5	69.9	67.2	63.9	60.5	56.7				
5- ³ / ₄	82.1	79.9	77.5	74.6	71.5	67.9	64.1				
6	89.9	87.8	85.3	82.5	79.3	75.8	71.9	67.8	63.3		
6- ¹ / ₄	98.1	95.9	93.5	90.6	87.5	83.9	80.1	75.9	71.5		
6- ¹ / ₂	106.6	104.5	101.9	99.1	95.9	92.5	88.6	84.5	79.9		
6- ³ / ₄	115.5	113.3	110.8	107.9	104.8	101.3	97.5	93.3	88.8		
7	124.6	122.5	119.9	117.1	113.9	110.5	106.6	102.5	97.9	93.1	87.9
7- ¹ / ₄	134.1	131.9	129.5	126.6	123.5	119.9	116.1	111.9	107.5	102.6	97.5
7- ¹ / ₂	143.9	141.7	139.3	136.5	133.3	129.8	125.9	121.8	117.3	112.5	107.3
7- ³ / ₄	154.1	151.9	149.5	146.6	143.5	139.9	136.1	131.9	127.5	122.6	117.5
8	164.6	162.5	149.9	157.1	153.9	150.5	146.6	142.5	137.9	133.1	127.9
8- ¹ / ₄	175.4	173.3	170.8	167.9	164.8	161.3	157.5	153.3	148.8	143.9	138.8
8- ¹ / ₂	186.6	184.4	181.9	179.1	175.9	172.5	168.6	164.5	159.9	155.1	149.9
8- ³ / ₄	198.1	195.9	193.9	190.6	187.4	183.9	180.1	175.9	171.4	166.6	161.5
9		207.8	205.3	202.4	199.3	195.8	191.9	187.8	183.3	178.5	173.3
9- ¹ / ₂		232.4	229.9	227.1	223.9	220.4	216.6	212.4	207.9	203.1	197.9
10			255.9	253.1	249.9	246.4	242.6	238.4	233.9	229.1	223.9
10- ¹ / ₂			283.3	280.4	277.3	273.8	269.9	265.8	261.3	256.4	251.3
11					305.9	302.4	298.6	294.4	289.9	285.1	279.9

MUD DENSITY, GRADIENT AND BUOYANCY FACTOR

NOTE: Buoyancy factor is for STEEL only

Mud density			Gradient psi/ft	Buoyancy Factor	Mud density			Gradient psi/ft	Buoyancy Factor
kg/m ³	lb/gall	lb/ft ³			kg/m ³	lb/gall	lb/ft ³		
1000	8.34	62.4	.433	.873	1800	15.0	112	.779	.771
1010	8.40	62.8	.436	.872	1820	15.2	114	.790	.768
1030	8.50	64.3	.447	.869	1850	15.4	115	.800	.765
1060	8.80	65.8	.457	.866	1870	15.6	117	.810	.762
1080	9.00	67.3	.468	.862	1890	15.8	118	.821	.759
1100	9.20	68.8	.478	.860	1920	16.0	120	.831	.755
1130	9.40	70.3	.488	.856	1940	16.2	121	.842	.753
1150	9.60	71.8	.499	.853	1970	16.4	123	.852	.749
1154	9.625	72.0	.500	.853	1990	16.6	124	.862	.746
1180	9.80	73.3	.509	.850	2010	16.8	126	.873	.743
1200	10.0	74.8	.519	.847	2040	17.0	127	.883	.740
1220	10.2	76.3	.530	.844	2060	17.2	129	.894	.737
1250	10.4	77.8	.540	.841	2090	17.4	130	.904	.734
1270	10.6	79.3	.551	.838	2110	17.6	132	.914	.731
1290	10.8	80.8	.561	.835	2130	17.8	133	.925	.728
1320	11.0	82.3	.571	.832	2160	18.0	135	.935	.725
1340	11.2	83.8	.582	.829	2180	18.2	136	.945	.722
1370	11.4	85.3	.592	.826	2210	18.4	138	.956	.719
1390	11.6	86.8	.603	.823	2230	18.6	139	.966	.716
1410	11.8	88.3	.613	.820	2250	18.8	141	.977	.713
1440	12.0	89.8	.623	.817	2280	19.0	142	.987	.710
1460	12.2	91.3	.634	.814	2300	19.2	144	.997	.707
1490	12.4	92.8	.644	.810	2330	19.4	145	1.01	.704
1510	12.6	94.3	.655	.808	2350	19.6	147	1.02	.701
1530	12.8	95.8	.665	.804	2370	19.8	148	1.03	.698
1560	13.0	97.3	.675	.801	2400	20.0	150	1.04	.694
1580	13.2	98.7	.686	.798	2420	20.2	151	1.05	.692
1610	13.4	100	.696	.795	2450	20.4	153	1.06	.688
1630	13.6	102	.706	.792	2470	20.6	154	1.07	.685
1650	13.8	103	.717	.789	2490	20.8	156	1.08	.682
1680	14.0	105	.727	.786	2520	21.0	157	1.09	.679
1700	14.2	106	.738	.783	2540	21.2	159	1.10	.676
1730	14.4	108	.748	.780	2570	21.4	160	1.11	.673
1750	14.6	109	.758	.777	2590	21.6	162	1.12	.670
1770	14.8	111	.769	.774	2610	21.8	163	1.13	.667



IADC DULL BIT GRADING



CUTTING STRUCTURE		BEARINGS/ SEALS	GAGE	OTHER DULL CHAR.	REASON PULLED
INNER	OUTER				
①	②	⑤	⑥	⑦	⑧

ORDER CODE #6320-23M

① INNER CUTTING STRUCTURE (All inner rows.)

② OUTER CUTTING STRUCTURE (Gage row only.)
In columns 1 and 2 a linear scale from 0 to 8 is used to describe the condition of the cutting structure according to the following:

STEEL TOOTH BITS

A - measure of lost tooth height due to abrasion and/or damage.
0 - NO LOSS OF TOOTH HEIGHT.
8 - TOTAL LOSS OF TOOTH HEIGHT.

INSERT BITS

A - measure of total cutting structure reduction due to lost, worn and/or broken inserts.
0 - NO LOST, WORN AND/OR BROKEN INSERTS.
8 - ALL INSERTS LOST, WORN AND/OR BROKEN.

FIXED CUTTER BITS

A - measure of lost, worn and/or broken cutting structure.
0 - NO LOST, WORN AND/OR BROKEN CUTTING STRUCTURE.
8 - ALL OF CUTTING STRUCTURE LOST, WORN AND/OR BROKEN.

③ DULL CHARACTERISTICS
(Use only cutting structure related codes.)

* BC - Broken Cone	LT - Lost Teeth/Cutters
BT - Broken Teeth/Cutters	OC - Off Center Wear
BU - Balled Up Bit	PB - Pinched Bit
* CC - Cracked Cone	PN - Plugged Nozzle/Flow Passage
* CD - Cone Dragged	RG - Rounded Gage
CI - Cone Interference	RO - Ring Out
CR - Cored	SD - Shirltail Damage
CT - Chipped Teeth/Cutters	SS - Self Sharpening Wear
ER - Erosion	TR - Tracking
FC - Flat Crested Wear	WO - Washed Out Bit
HC - Heat Checking	WT - Worn Teeth/Cutters
JD - Junk Damage	NO - No Dull Characteristic
* LC - Lost Cone	
LN - Lost Nozzle	

* Show cone # or #'s under location ④.

④ LOCATION

ROLLER CONE

N - Nose Row	CONE #
M - Middle Row	1
G - Gage Row	2
A - All Rows	3

⑤ BEARINGS / SEALS

NON-SEALED BEARINGS
A linear scale estimating bearing life used. (0 - No life used, 8 - All life used, ie. no bearing life remaining.)

⑥ GAGE Measure in fractions of an inch.
I - in gage
1/16 - 1/16" out of gage
1/8 - 1/8" out of gage
1/4 - 1/4" out of gage

⑦ OTHER DULL CHARACTERISTIC
Refer to column 3 codes.

⑧ REASON PULLED OR RUN TERMINATED

BHA - Change Bottom Hole Assembly	HR - Hours On Bit
DMF - Downhole Motor Failure	LOG - Run Logs
DTF - Downhole Tool Failure	PP - Pump Pressure
DSF - Drill String Failure	PR - Penetration Rate
DST - Drill Stem Test	RIG - Rig Repair
DP - Drill Plug	TD - Total Depth/Casing Depth
CM - Condition Mud	TW - Twist Off
CP - Core Point	TQ - Torque
FM - Formation Change	WC - Weather Conditions
HP - Hole Problems	
LH - Left In Hole	

FOR ADDITIONAL INFORMATION CONTACT YOUR LOCAL SECURITY REPRESENTATIVE OR SECURITY DIVISION IN DALLAS, TEXAS. (214) 333-3211

Attachment 3

n	2.0	1.9	1.8	1.7	1.6	1.5	1.4	1.3	1.2	1.1	1.0
W IF	0.50	0.51	0.53	0.54	0.56	0.57	0.59	0.61	0.60	0.65	0.67
W HHP	0.33	0.34	0.36	0.37	0.38	0.40	0.42	0.43	0.45	0.48	0.50

NOZZLE SIZE	NOZZLE AREA (in.²)
18-18-18	0.75
18-19-17	0.72
18-17-17	0.69
17-17-17	0.67
17-17-16	0.64
17-16-16	0.61
16-16-16	0.59
16-16-15	0.57
16-15-15	0.54
15-15-15	0.52
15-15-14	0.50
15-14-14	0.47
14-14-14	0.45
14-14-13	0.43
14-13-13	0.41
13-13-13	0.39
13-13-12	0.37
13-12-12	0.35
12-12-12	0.33
12-12-11	0.31
12-11-11	0.30
11-11-11	0.28
11-11-10	0.26
11-10-10	0.25
10-10-10	0.23
10-10-9	0.22
10-9-9	0.20
9-9-9	0.19
9-9-8	0.17
9-8-8	0.16

VOLUMETRIC CAPACITIES

	bbls/ft	ft³/ft
Casing		
13 3/8" 72 lb/ft Casing:	0.1480	0.8314
Open Hole		
18" Hole	0.3147	1.7671
Annular Spaces		
20" Casing x 13 3/8" Casing	0.1815	1.0190
18" Hole x 13 3/8" Casing	0.1410	0.7914

The Adaptation of Wilson's Equations to Wellbore Stability Prediction

Wilson's equations have been adapted to the prediction of wellbore stability by allowing for:

- (1) Pore pressure within the host rock (via concept of effective stress)
- (2) The orientation of the wellbore at some angle other than 90° to the horizontal stresses, i.e. hole deviation from 0 to 90°
- (3) Non-hydrostatic stress fields

Thus for a vertical well, the radius to the outer limit of the yield zone is given by the equation below.

The equation predicting the yield zone radius in a thick production zone is:

$$\frac{r_e}{a} = \left\{ \frac{2q - \sigma_o + p'(k+1)}{(p+p')(k+1)} \right\} \frac{1}{k-1}$$

Where

r_e = Radius to outer limit of yield zone
 a = Radius of borehole
 k = Triaxial factor for rock

$$= \left\{ \frac{1 + \sin \phi}{1 - \sin \phi} \right\}, \phi \text{ being the angle of internal friction for the rock}$$

σ_o = In situ unconformed compressive strength
 p = Effective stress applied to the sides of the wellbore
 = Mud pressure - pore pressure

$$p' = \frac{\sigma'_o}{k-1}, \sigma'_o \text{ being found from the equation } \sigma'_1 = \sigma'_o + k\sigma'_3$$

for broken rock in the yield zone

$$= 0.1 \text{ mPa}_a \text{ or } 15 \text{ psi typically for soft rock}$$

q = Effective hydrostatic stress remote from the opening
 = (overburden stress x stress ratio) - pore pressure

**HERIOT-WATT UNIVERSITY
DEPARTMENT OF PETROLEUM ENGINEERING**

**Examination for the Degree of
MSc/Diploma Distance Learning course in Petroleum Engineering**

Drilling Engineering

**Monday 10th January 2000
09.30 - 12.30**

NOTES FOR CANDIDATES

1. This is a Closed Book Examination.
2. 15 minutes reading time is provided from 09.15 - 09.30.
3. Examination Papers will be marked anonymously. See separate instructions for completion of Script Book front covers and attachment of loose pages. Do not write your name on any loose pages which are submitted as part of your answer.
4. This Paper consists of 2 Sections:- A and B.
5. Section A:- Attempt 5 numbered Questions
Section B:- Attempt 3 numbered Question
6. Section A:- 40% of marks [8% per Question]
Section B:- 60% of marks

Marks for Question parts are indicated in brackets

7. This Examination represents 100% of the Class assessment.
8. State clearly any assumptions used and intermediate calculations made in numerical questions. No marks can be given for an incorrect answer if the method of calculation is not presented.
9. Answers must be written in separate, coloured books as follows:-

Section A:- Blue
Section B:- Green

Section A

A1

- (a) List and briefly discuss three functions of the drill collars used in the BHA of drillstrings. [3]
- (b) List and describe the function of two other components (other than drillcollars) of the BHA. [5]

A2

- (a) List and discuss three elements of the design of a PDC bit which would be suitable for a soft claystone formation. [3]
- (b) Briefly describe the structure and content of the IADC dull grading system. [5]

A3

- (a) List and discuss the major considerations when selecting/designing a drilling fluid for a particular well. [5]
- (b) What are the advantages and disadvantages of oil based mud as opposed to water based mud? [3]

A4

- (a) Discuss the reasons for conducting a leakoff test when drilling out of a casing shoe. [2]
- (b) List and describe the procedure for conducting such a test and the calculations that are conducted when the results are obtained. [6]

A5

- (a) Draw and annotate the shear stress vs. Shear rate diagram for a: Power law and; Bingham Plastic Drilling Fluid. [3]
- (b) Write the mathematical model for each of the models discussed above. [2]
- (c) Draw the friction factor vs. Reynolds number relationship for a Power law Fluid and show the impact of the non-Newtonian index on the relationship. [4]

A6

- (a) List and describe the surface and subsurface components of an MWD system. [6]
- (b) Describe two of the modes of data transmission used in mud pulse telemetry systems. [2]

A7

- (a) A typical casing string may be described by the following terms:

9 5/8" 47 lb/ft L-80 VAM

Explain the meaning of each of the terms in this description. Use examples of alternatives to highlight the attributes of this particular casing.

[8]

A8

- (a) List and discuss the constraints on the trajectory of a wellbore which must be considered when designing the wellpath of a deviated well. [3]
- (b) Given that the rig position and target location are often fixed, what control does the engineer exercise when designing the geometry of the wellpath. Discuss the practical/operational limitations on the geometry of the wellpath? [5]

Section B

B9 The intermediate casing of a development well is to be cemented in place using a two stage cement job.

13 3/8" Setting Depth	: 5900 ft.
17 Ω" Hole (Calipered to 18")	: 5930 ft
Previous Shoe Depth (20")	: 1500 ft.
Formation Fluid Density	: 9 ppg
Shoetrack	: 60 ft

Cement stage 1 (5930-4500 ft.)	
Class 'G' + 0.2% D13R (retarder)	: 15.8 ppg
Yield of Class 'G' + 0.2% D13R	: 1.15 ft ³ /sk
Mixwater Requirements	: 0.67 ft ³ /sk

Cement stage 2 (1500-1000 ft.)	
Class 'G' + 8% bentonite + 0.1% D13R	: 13.2 ppg
Yield of Class 'G' + 8% bentonite + 0.1% D13R	: 1.89 ft ³ /sk
Mixwater Requirements	: 1.37 ft ³ /sk

(a) Calculate the following (See Attachment 1 for capacities):

- (i) The required number of sacks of cement for the 1st stage and 2nd stage of the job (Allow 10% excess over caliper in open hole).
- (ii) The volume of mixwater required for each stage.
- (iii) The displacement volume for each stage.

[12]

(b) List and discuss three properties of cement which would be specified when designing the cementation operation.

[6]

(c) Discuss the possible reasons why a two stage cementation job was programmed for this casing.

[2]

B10 Whilst drilling the 12 1/4” hole section of a vertical well with a mudweight of 11 ppg the driller detects a kick. The well is shut in and the following information is gathered

Surface Readings :

Shut in Drillpipe Pressure : 700 psi
Shut in Annulus Pressure : 900 psi
Pit Gain : 29 bbls

Hole / Drillstring Data :

Hole Size : 12 1/4 “
Depth of kick : 6500 ft.
Previous Casing Shoe : 13 3/8”, 54.5 lb/ft
Depth 13 3/8” shoe : 3500 ft. TVD

BHA : Bit : 12 1/4”
Drillcollars : 500 ft of 9” x 2 13/16”
Drillpipe : 5”, 19.5 lb/ft

(a) Calculate and discuss the following :

- (i) The type of fluid that has entered the wellbore ?
- (ii) The mudweight required to kill the well.
- (iii) The volume of kill mud that would be required to kill the well.

[10]

(b) Briefly explain how and why the wellbore pressure is monitored and controlled throughout the well killing operation (assuming that the ‘one circulation method’ is to be used).

[6]

(c) Briefly explain why the ‘one circulation method’ is considered to be safer than the drillers method for killing a well.

[4]

B11 The 9 5/8” production casing string of a well is to be designed for burst and collapse on the basis of the following data.

Setting Depth of 9 5/8” Casing	:	8320 ft
Top of Production Packer	:	7500 ft
Formation Fluid Density	:	9 ppg
Expected gas gradient	:	0.115 psi/ft
Depth of Production Interval (TVD)	:	7750 - 8220 ft
Maximum expected pressure in production intervals	:	4650 psi
Packer fluid density	:	9 ppg
Design Factors (burst)	:	1.1
(collapse)	:	1.1

Casing Available (See Attachment 2 for specifications of this casing):

9 5/8” 47 lb/ft P-110 VAM
9 5/8” 53.5 lb/ft P - 110 VAM

Note :

1. Only one weight and grade of casing is to be used in the string

- (a) Design the casing for Burst and Collapse loads (do not consider the tensile loads). Discuss **critically** the scenarios considered when determining the loading conditions used in the above design process.

[8]

- (b) List and describe four (4) of the tensile loads which would be considered when designing the casing for tension.

[6]

- (c) List and discuss the operations involved in running casing, from the point at which it arrives on the rig, to the point at which the cementing operation is about to commence.

[6]

B12 It has been decided to drill a deviated well to a target at 8700 ft. TVD. The well is to be kicked off just below the 13 3/8" casing at 2000 ft. The well is to have a build and hold profile. The details of the well profile are as follows :

KOP	:	2000 ft.
Target Depth (TVD)	:	8700 ft.
Horizontal Departure of Target	:	3200 ft.
Buildup Rate	:	2°/100ft

(a) Calculate the Following :

- (i) The drift angle of the well.
- (ii) The along hole depth at the end of the build up section.
- (iii) The along hole depth at the target.

[12]

(b) List and discuss the advantages and disadvantages of the various types of surveying systems that could be used to survey this well whilst drilling.

[4]

(c) List and discuss two types of tool or techniques that could be used to alter the direction of this well if it were found to be deviating from the designed course.

[4]

End of Paper

VOLUMETRIC CAPACITIES

	bbls/ft	ft ³ /ft
Drillpipe		
5" drillpipe :	0.01776	0.0997
Drillcollars		
9" x 2 13/16" Drill collar:	0.0077	0.0431
Casing		
13 3/8" 72 lb/ft Casing:	0.1480	0.8314
Open Hole		
18" Hole	0.3147	1.7671
Annular Spaces		
13 3/8" casing x 5" drillpipe:	0.1302	0.7315
12 1/4" hole x 5" drillpipe:	0.1215	0.6821
12 1/4" hole x 9" drillcollars:	0.0671	0.3767
18" hole x 13 3/8" Casing:	0.1410	0.7914
20" Casing x 13 3/8" Casing:	0.1815	1.0190

CASING LOAD RATINGS

	Burst (psi)	Collapse (psi)	Tension (lbs)
9 5/8" 47 lb/ft P-110 VAM	9440	5310	1493000
9 5/8" 53.5 lb/ft P - 110 VAM	10900	7930	1710000